



Parts Included

Number	Quantity	Item Description	Part #
1	2	Upper Control Arm	DK-922902-UCA
1A	8	Polyurethane Bushing	DK-PB65002
1B	2	1" Uniball	WSSX16T-F1
1C	4	Inner Bushing Sleeve	DK-IB870247
1D	2	1" Uniball Snap Ring	DK-SRID2125
2	1	Upper Control Arm Spacer Kit	DK-900925
2A	2	9/16" Tapered Misalignment Spacer	DK-900918
2B	2	9/16" Half Moon Spacer	DK-08870025
2C	2	9/16"-18 x 4.5" F911 Bolt	DK-CB180433
2D	2	9/16"-18 Grade 8 Nyloc Nut	G8-NN1800
2E	2	9/16" SAE Washer	G8-W68SAE
3	1	Grease Fitting Kit	DK-GFK001
3A	4	Grease Fitting	DK-ZF0890
3B	2	Grease Pack	82340
4	1	Variety Sticker Pack	DK-132357MCV

Carefully read all instructions prior to installation. This product must be installed by a qualified mechanic. Do not install with a coil spacer lift or shocks that over articulate the upper control arms.

Pre Installation

Take your vehicle and park it on level ground applying your parking brake. Then place wheel chocks behind the rear wheels. Break loose the lug nuts and jack up the front of the truck until the wheels are off the ground. Place jack stands securely under each side of the frame rails. Slightly jack up the passenger side suspension to release tension off the upper arm. Remove the wheel and leave the jack under the lower arm.

Removal

First loosen the sway bar end link from the sway bar. Loosen the ball joint nut until about half inch from spindle. (figure 1) With a hammer hit the side of the spindle until the ball joint breaks free. Now loosen the upper arm bolts that attach it to the frame. Next remove the shock from the vehicle to allow for the upper arm bolts to be removed. Be cautious not to stretch the brake line or abs wires in the process.

Figure 1

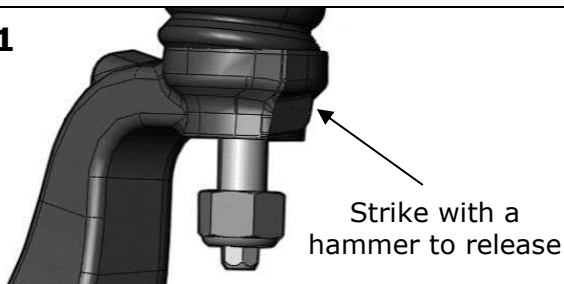

Installation

Start by threading in the grease fittings on top of the arm. With the supplied grease apply some to the outside of each bushing. (figure 2) Install the Dirt King upper arm using the factory bolts to the frame. Place a small amount of red loctite® on the threads, then torque the nuts to 114ft lbs. Reinstall the shock into the coil bucket. Torque the upper nuts that attach it to the coil bucket to 35ft lbs. Insert the shock to the lower arm and reinstall the shock bolt. The factory lower shock bolt must be tightened once the vehicle is on its own weight. Now attach the upper arm to the spindle. Insert the misalignment spacers into the uniball and then place the tapered spacer into the spindle.

Figure 2

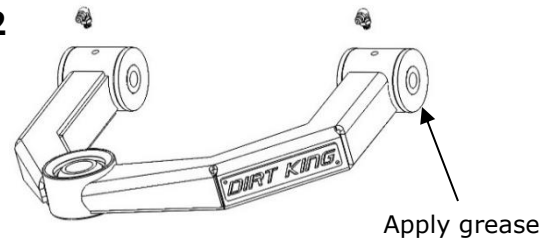

Make sure that the spacers are fully inserted into the uniball and spindle before tightening the bolt or damage will occur. (figure 3) Torque the 9/16" nut to 100ft lbs with red loctite® on the threads.

Figure 3

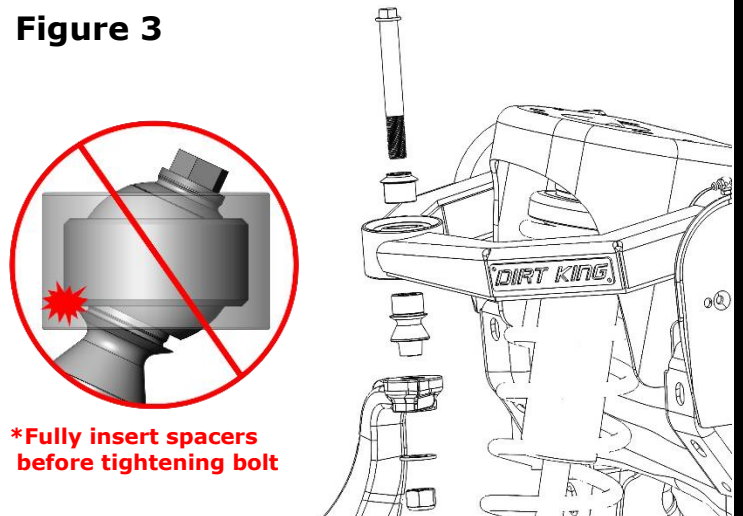

Repeat these steps to the opposite side. Once both sides are complete, reattach the sway bar end links and torque the lower shock nuts to 351ft lbs while the vehicle is on the ground (2014 models must be torqued to 66ft lbs.). Make sure the brake lines and abs lines won't get snagged or stretched while turning. Do a visual inspection ensuring everything is tight and installed correctly.

Alignment

Your vehicle will need to be aligned by a qualified shop. Our arms have increased castor built in to compensate for lifting the vehicle. The additional castor helps with straight line stability and improved handling.

Maintenance

Over time you will need to grease the bushings using the zerk fittings and use a Teflon based dry lubricant for the uniballs. We recommend Super Lube Synthetic Grease for the bushings and Tri-Flo lubricant for the uniballs.



THE FOLLOWING TERMS AND CONDITIONS APPLY TO ALL ORDERS PLACED WITH DIRT KING FABRICATION (WEBSITE, PHONE, FAX, MAIL, OR E-MAIL), EITHER DIRECTLY OR THROUGH A DEALER, CONSTITUTE THE ACKNOWLEDGEMENT AND ACCEPTANCE OF ALL THE CONDITIONS LISTED BELOW:

All products sold or manufactured by Dirt King Fabrication are intended for off-road use only. Our suspension systems are not to be modified from its original design in any way. Dirt King Fabrication is not responsible or liable for any accidents, injuries or deaths that may occur from the use of any products offered. Installation of this system will alter the center of gravity of the vehicle and may increase the risk of a roll over as compared to stock. It is the responsibility of the customer to check if any products will void their vehicles warranty before installation. Customer assumes all liability in assuring that parts are correctly installed and maintained. We are not responsible for products that don't fit correctly on a vehicle which has been in an accident. Consult your local laws before installing any products.

Shipping & Delivery

At this time, Dirt King Fabrication ships merchandise to locations within the United States and U.S. territories, including Alaska, Hawaii, Puerto Rico, Guam, and the US Virgin Islands. Additionally, Dirt King Fabrication ships merchandise to Canada and Mexico, but not to other international locations. The risk of loss and title for all merchandise ordered pass to you when the merchandise is delivered to the shipping carrier.

Return Policy

- Returns are only accepted within 30 days of original purchase.
- Original copy of invoice must be provided
- We are not responsible for shipping on returned products.
- 15% restocking fee will be charged on all returns.
- Deposits on custom orders or products built to order are non-refundable.
- Parts must be returned in the original package and condition as they were sent.
- No returns on items that have been damaged or installed.

Missing or Defective Parts

Dirt King Fabrication goes through various stages of quality control to insure all parts are included and packaged correctly however there may be an instance where something is looked over. If there is a missing or defective part a claim must be made with Dirt King Fabrication within 60 days of original purchase. Photos of the box's exterior and contents must be e-mailed along with a description of what's missing or defective. If the box has any holes, tears or damage from shipping Dirt King Fabrication will determine if it's a claim that must be made with the shipping carrier. For defective parts photos need to be taken prior to install.

Core Charges

- All cores must be original OEM parts. Remanufactured parts will not be accepted.
- All cores must be received within 30 days of purchase for full credit.
- Partial or no credit will be issued if core is damaged or modified in any way.

Maintenance

After initial installation parts may make a clunking or creaking sound until the heims, uniballs, and bushings settle and are broken in. After a 50 mile break in period you must go through and re-torque all of the bolts. Over time you will also need to apply a Teflon based dry lubricant spray to the uniballs and heims. The bushings will need to be greased through the grease fittings. This will increase the lifespan of the joints and help prevent them from making noise. Inspect these items periodically for unusual wear and replace if necessary. Replacement is necessary if any of the heims, uniballs, or bushings has an excessive amount of movement.

Driver Side

- Grease fittings threaded into arm.
- Grease the outside of the polyurethane bushings.
- Upper arm bolts to the frame torqued to 114ft lbs with red loctite.
- Upper arm bolt to the spindle torqued to 100ft lbs with red loctite.
- Tire re-installed and lug nuts torqued down.
- Factory upper shock nuts torqued to 35ft lbs.
- Factory lower shock nut torqued to 351ft lbs. (66ft lbs on 2014 models)

Passenger Side

- Grease fittings threaded into arm.
- Grease the outside of the polyurethane bushings.
- Upper arm bolts to the frame torqued to 114ft lbs with red loctite.
- Upper arm bolt to the spindle torqued to 100ft lbs with red loctite.
- Tire re-installed and lug nuts torqued down.
- Factory upper shock nuts torqued to 35ft lbs.
- Factory lower shock nut torqued to 351ft lbs. (66ft lbs on 2014 models)

Both Sides

- Do a visual check on all the work and set alignment.