

Thank you for your purchase of our new SS3 Type SDX Foglight Kit. CAD-designed to use existing mounting points, this kit is compatible with the 2000-2005 Ford Excursion and 1999-2010 Ford F-250/F-350 models. Basic installation instructions are included below.

Please contact us if you have any questions.



Tools Needed: 8mm Socket, Trim Removal Tool or Flathead Screwdriver



IMPORTANT: This installation guide is based on the 99-07 model years, which place the fog lights in the lower grill. Model years 08-10 place the fog lamps outboard from the tow hooks, requiring one to reach under the bumper to access OEM lamp mounting hardware. The steps listed below apply to 08-10 models as they use the same lamp, but images may not exactly match these vehicles.

1. Remove license plate holder (if applicable).
2. Remove OEM lamp aim adjustment screw and compression spring. Use an 8mm socket. Access the screw from the rear of the bracket, reaching through the lower grill or from the underside of the bumper. This hardware will be reused.
3. Remove OEM lamp. Using a trim removal tool or a flathead screwdriver, remove the two plastic push-rivets holding the lamp on the OEM bracket. These will be reused. The outboard push rivet can be accessed by reaching through the tow hook opening in the bumper. Gently pass the lamp through the opening in the bumper. This can be performed with the OEM bracket in place, but some may find it easier to unbolt the bracket. If this is desired, use an 8mm socket to remove the two bolts on the top and the one bolt on the bottom.
4. Transfer the plastic nut insert from OEM lamp to the new Type SDX bracket. Use needle-nose pliers to remove the clip from the OEM lamp, and gently press it into the Type SDX bracket.

NOTE: Replacement OEM Lamps produced in 2011 or later use a different style clip intended for a round mating hole. This clip will initially feel loose when reused on the Type SDX bracket but it will firmly hold the bracket in place when carefully installed and properly aimed.

See back for further instructions.

5. Firmly mount the SS3 pod on the Type SDX bracket. Note that the same bracket is used for the driver and passenger sides of the vehicle. Ensure the lamp is installed such that the DT power connector is on the “bottom” of the lamp and the SAE markings are readable when installed on the vehicle. Firmly tighten the mount screws with the lamp aimed straight forward as shown below, as final aiming will be completed with the OEM adjustment.

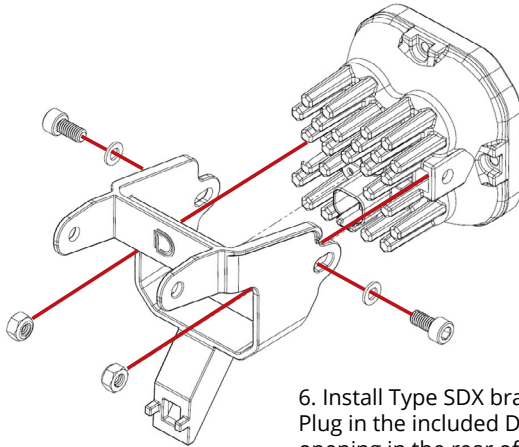

Left and Right Sides

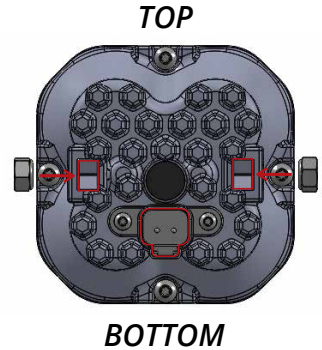

6. Install Type SDX bracket and SS3 assembly onto the vehicle. Plug in the included DT to H10 adapter, and pass it through the opening in the rear of the OEM lamp bracket. Reuse the OEM plastic push-rivets on the top of the bracket. Reinstall the OEM lamp bracket if removed in step 3.

7. Adjust and aim the fog light according to your local and state laws. Using an 8mm socket, install the OEM aim adjustment screw and compression spring as shown to the right. Tighten the adjustment screw until satisfied with the beam position.

8. Repeat steps 2 through 7 for the other side of the vehicle.

9. Reinstall license plate holder (if applicable).

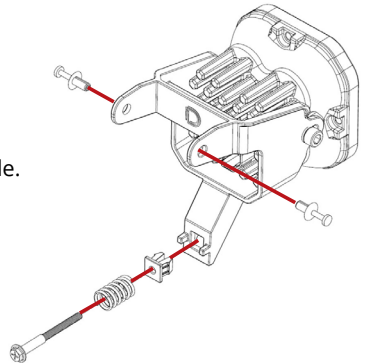

This installation guide is for the following SKUs:

DD6539 Worklight SS3 Sport Type SDX Kit White SAE Driving
DD6540 Worklight SS3 Sport Type SDX Kit White SAE Fog
DD6541 Worklight SS3 Sport Type SDX Kit Yellow SAE Fog
DD6542 Worklight SS3 Pro Type SDX Kit White SAE Driving

DD6543 Worklight SS3 Pro Type SDX Kit White SAE Fog
DD6544 Worklight SS3 Pro Type SDX Kit Yellow SAE Fog
DD6702 Worklight SS3 Max Type SDX Kit White SAE Fog
DD6703 Worklight SS3 Max Type SDX Kit Yellow SAE Fog