

DIODE DYNAMICS

PERFORMANCE LIGHTING TECHNOLOGY

11. Connect the 4-pin JST connector on the driver to the pigtail . Tap the wires on the harness to your desired 12V signals, determining when the LEDs will be turned on. In the table below, we have listed the suggested wires to tap.

IMPORTANT: DO NOT plug the LED panel directly into controller without the driver. The LEDs must be plugged into driver first to control the power.

Upper and Lower DRL

DD WIRE	FUNCTION	PIN	HARNES LOCATION	DRIVER WIRE	PASSENGER WIRE
WHITE*	Low White, 50% Brightness	PIN 1	Headlight	Yellow	Yellow
BLACK	Ground	PIN 2	Headlight	Black	Black
YELLOW	Turn Signal	PIN 1	Turn Signal	Blue/White	Green/Violet
RED*	High White, 100% Brightness	F40	Fuse Box	DRL Power Wire Harness	
BLUE (Solid State)	Park/DRL	PIN 8	Headlight	N/A	Blue/Brown

* Optional override white, do not connect for manual control of colors at all times.

OPTIONAL: DRL Override Feature - This feature allows you to automatically switch the LEDs to a high-brightness White color when power is applied to the red input signal, "overriding" the controller color selected. We recommend connecting this to ignition power using the supplied DRL Power Wire Harness, to automatically switch to White when the vehicle is running. This allows you to leave the LEDs set to an accent color of your choice, then automatically switch to White while driving. If you would like to adjust the colors manually at all times, you can skip this feature by leaving the signal disconnected.

12. Connect the DRL Power Wire harness to the Add a Fuse . Then replace fuse F40 with the Add a Fuse. Reinstall the OEM fuse in the open slot closest to the pins on the Add a Fuse.

NOTE: If you are installing both the upper and lower DRL boards, tap the red wire from the pigtail to the DRL power wire harness that was previously installed. You will not need the second DRL harness.

13. Next, route the DRL harness wires to the headlight harness on each side of the vehicle. Connect the red wire from the DRL Power Wire harness to the red wire on each driver.

14. Mount drivers and controller, and tuck all wires. Drivers should be mounted outside of headlight for serviceability, in a location away from the engine block to avoid excessive head buildup. Test thoroughly, reseal headlights and reinstall onto vehicle.

This installation guide is for the following SKUs:

DD2222 Camaro 2016 RGBWA DRL Boards

DD2242 Camaro 2016 RGBWA Lower DRL Boards

2016 - 2018 Chevrolet Camaro RGBWA™ DRL LED Board Installation Guide



Thank you for your purchase of this unique product for your Chevrolet Camaro! With these modules, you will be able to convert your factory LEDs inside the headlight into full multicolor functionality, along with an amber turn signal feature. They are a direct replacement for the factory LED panels inside the light.



Please note: Headlights must be opened before proceeding with installation. Before baking the headlight, remove the T20 torx screws holding the ballast to the housing and the three T20 torx screws holding the LED driver to the housing. Disconnect the OEM harness from ballast. Professional installation is strongly recommended. Please contact Diode Dynamics if you need assistance locating an installer.

Tools Needed: Torx T10 and T20 Screwdriver

Upper DRL Board Installation:



1. Remove the six T20 torx screws holding the black bezel in place, including the screw on the backside of the housing. Set the bezel aside.

Remove the four T20 torx screws holding the white optics shroud in place and remove the optics shroud from the assembly.



2. Remove the four T10 torx screws holding the factory boards in place. Then remove the factory boards. They won't be reused.



3. Install your new Diode Dynamics LED boards. To do so, install the supplied spacers between the boards and the back of the optics shroud as shown in the picture to the left. The spacers must be used in order to allow enough clearance for the LED chips.



4. Secure the boards in place using the original T10 torx screws.



5. Connect the wiring harness to the LED boards. Ensure the shortest length on the wiring harness is connected to the L1/R1 boards.

Secure the wiring harness to the back of the board using the included zip ties. See picture to the left.



6. Using the original T20 screws, reinstall the white optics shroud and route the wires through the back of the headlight assembly, sealing any holes you may create.



7. Using the original T20 screws, reinstall the black bezel in the headlight assembly.

Once complete, repeat the same process for the other headlight.

Lower DRL Board Installation:



8. After the lens has been removed, remove the three T20 torx screws holding the reflector in place.

Remove the three T20 torx screws holding the LED board to the reflector. Remove the factory board and replace with your new Diode Dynamics LED board using the original screws.

Using the original screws, reinstall the reflector back into the housing. Repeat the same process for the other lamp.

Upper and Lower DRL Wiring Instructions

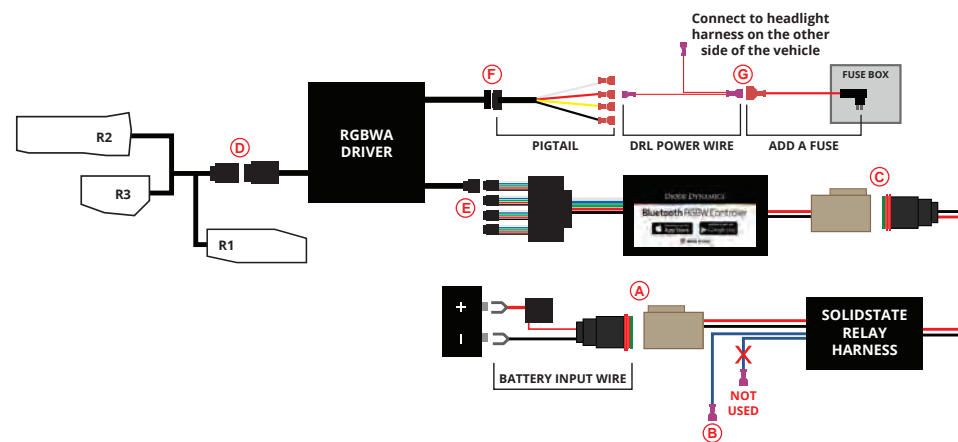

9. Connect the battery input wire to the SolidState Relay Harness (A). Run the battery input wire to the battery, and connect to the positive and negative battery terminals. Next, tap one of the blue wires from the SolidState Relay Harness to your power source (B). This will determine when the LEDs turn on. We suggest tapping the parking signal (Blue/Brown wire) on the Camaro passenger headlight harness, so the LEDs turn on with your parking lights. Alternatively, you can run this to your battery with a switch (not included) if you prefer manual activation and power. The other blue wire will not be used.

10. Connect the SolidState Relay Harness output to your RGBW Controller (C). Connect the LED board to the RGBW driver (D). Then route the RGBW extension wire to the driver side of the vehicle. Then connect the 5-pin JST connector on the driver to the controller (E).

See back for further instructions.