



Free Flow Exhaust Installation Instructions

**PART NUMBER
D660-0075 (-BLK)**

APPLICATION: 2018 G30 M550i xDrive

Thank you for purchasing a Dinan High Performance Muffler! Some mechanical skill is required to install this muffler. If you are not familiar with this procedure, we strongly recommend that you arrange for a qualified BMW repair facility to perform this installation.



INSTALLATION:

1. Disconnect the battery using BMW factory procedures (make sure the car is asleep).
2. Disconnect wires from both valve actuators. See figure below.

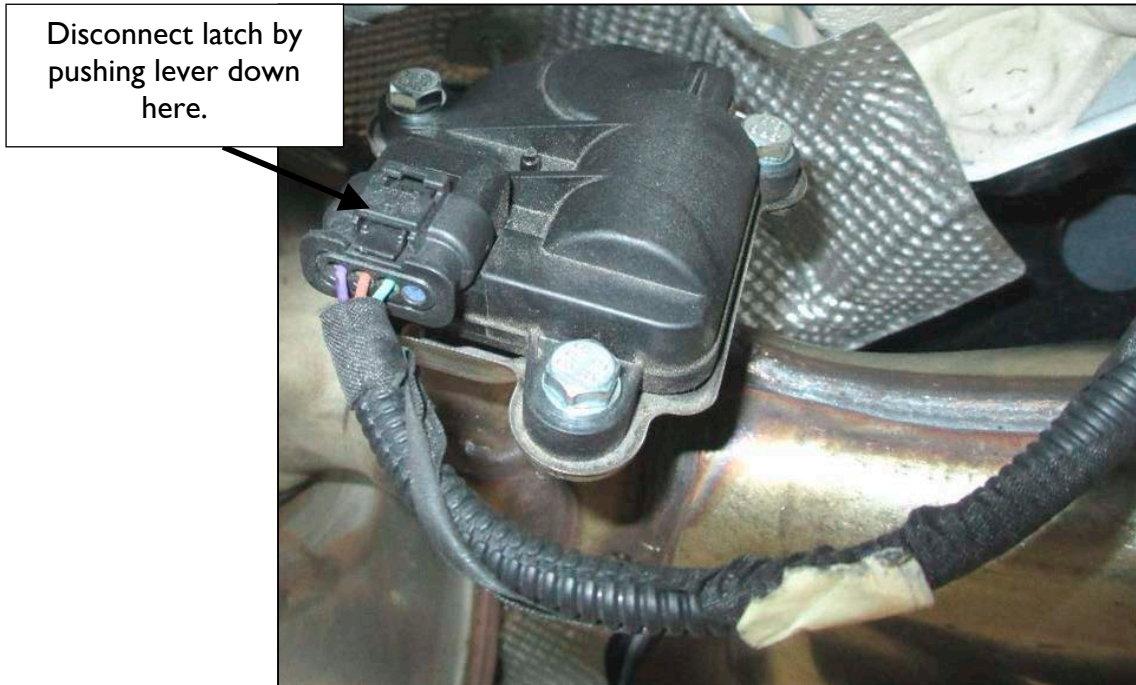

- Support the muffler securely with a jack or a stand, then cut the stock muffler at the BMW cut dimple location as shown in the figures below. Before cutting the stock muffler, hold DINAN muffler underneath stock muffler to verify the stock pipe will not be cut too short!

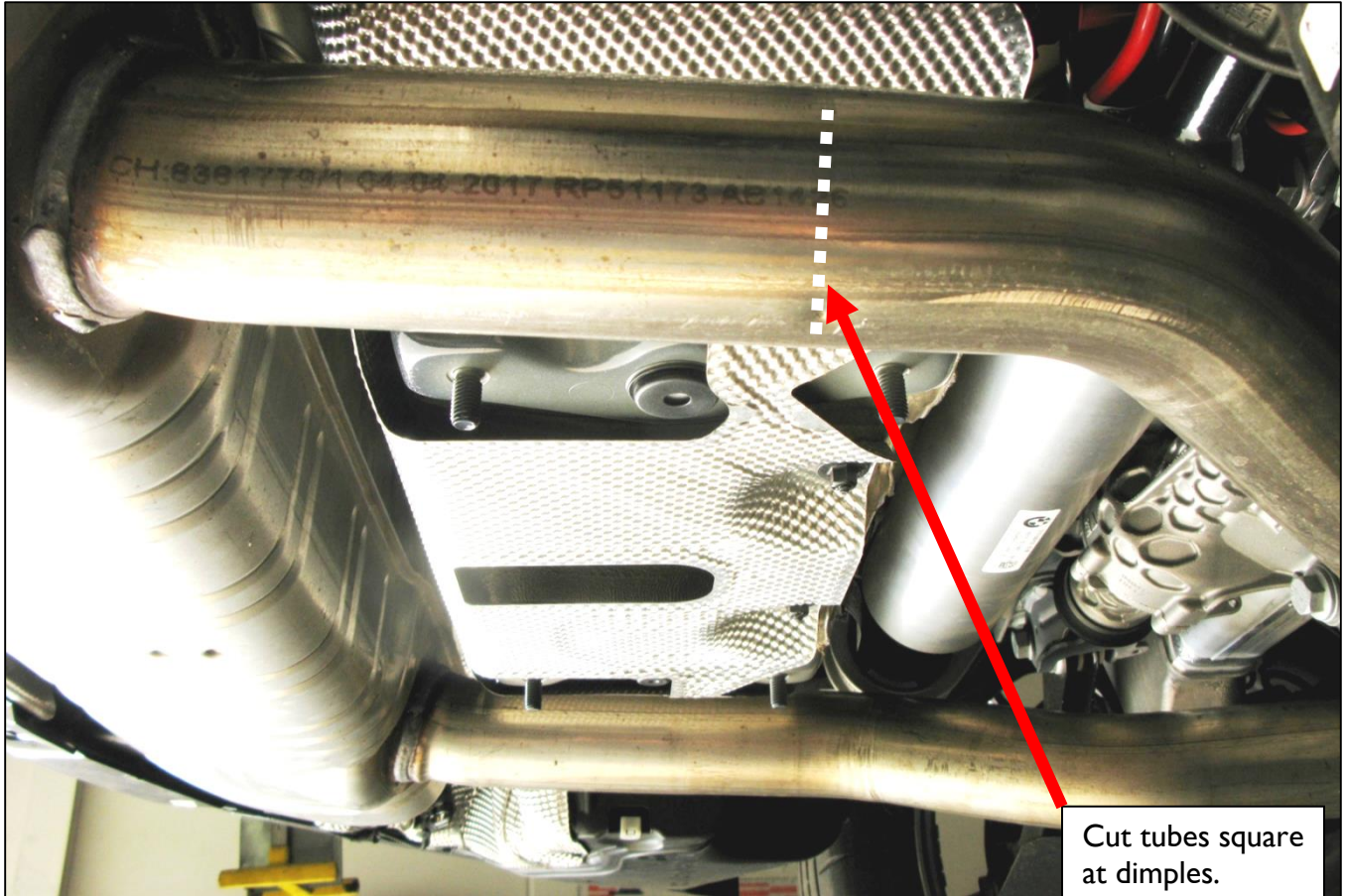

Cut tubes square at dimples.
See marked lines

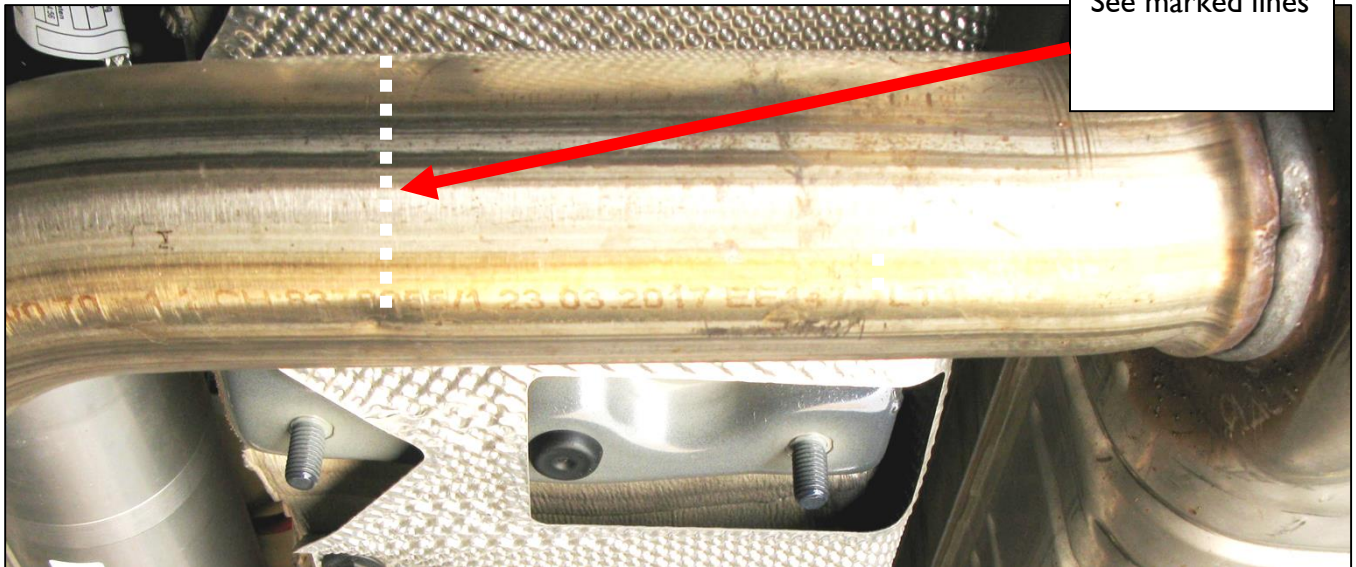

4. With the stock muffler fully secure and supported on a jack or stand, remove the hanger nuts as shown (SAVE THESE NUTS FOR INSTALLATION OF DINAN MUFFLER!), then remove stock muffler. Be sure exhaust valve actuators (1) are disconnected before finally removing the muffler.

Remove hanger nuts.
SAVE THESE FOR
INSTALLATION OF
DINAN MUFFLER!

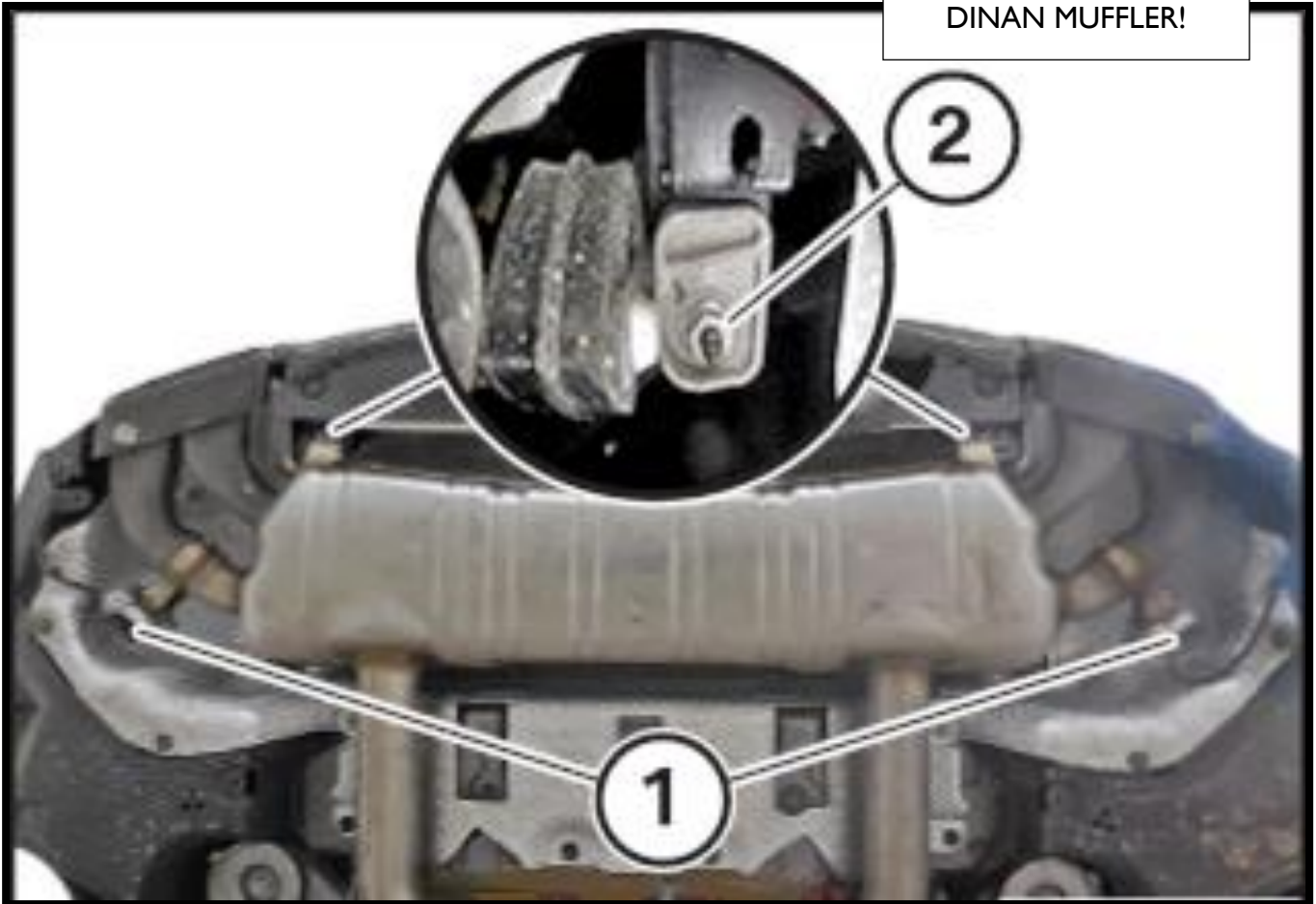

5. Remove both hangers and valve actuators from stock muffler. **SAVE THESE PARTS FOR INSTALLATION ON DINAN MUFFLER.**

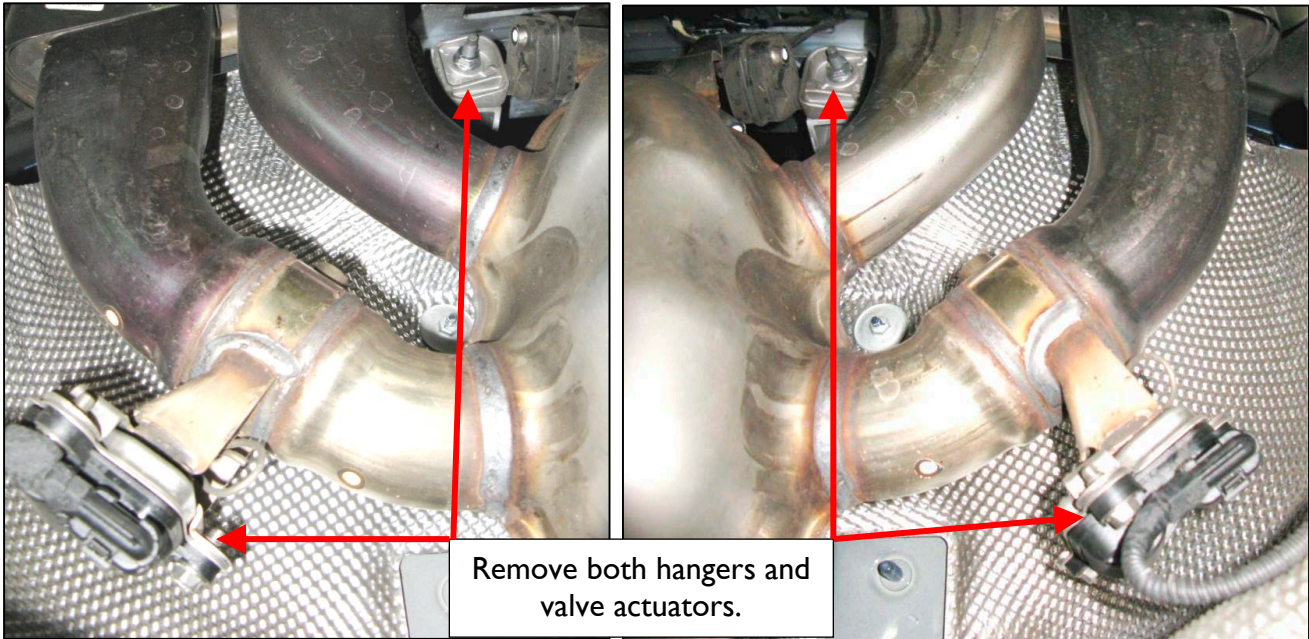

6. Install the valve actuator mounting brackets provided in the hardware kit as shown below. You will need (3) M6x20 bolts, (3) M6 locknuts, and (6) M6 washers from the hardware kit provided to install each mounting bracket. Notice the location of the spacer for mounting the actuator in the next step. Make sure all hardware is tight.

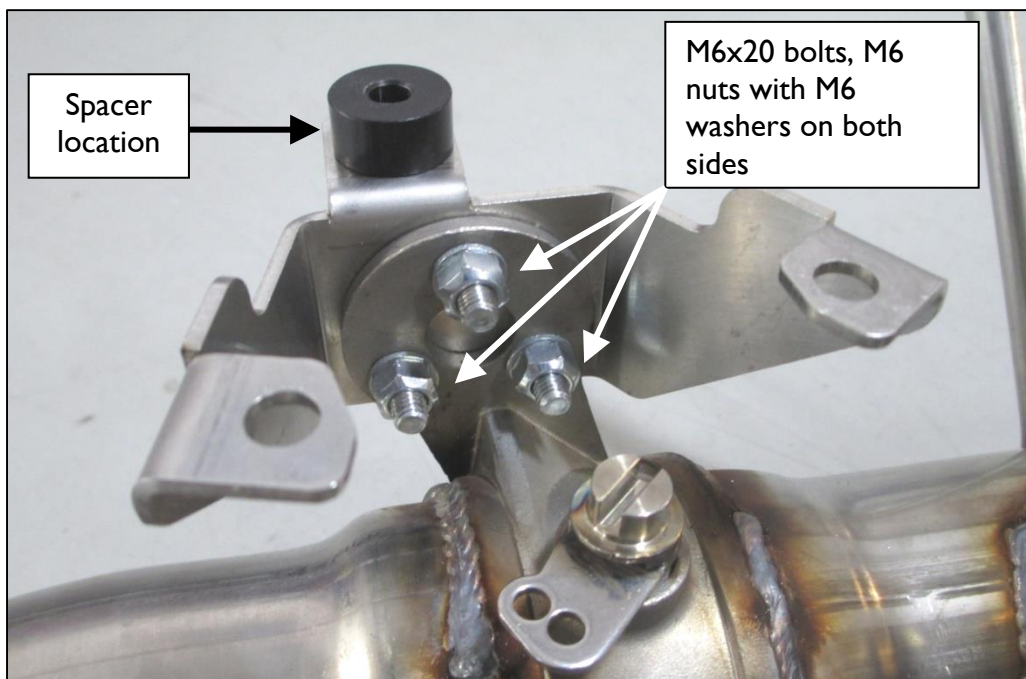

7. Install stock actuators onto DINAN muffler. You will need (2) M6x20 bolts, (1) M6x30 bolt, (3) M6 locknuts, (6) M6 washers, and (1) spacer from the hardware kit provided for each actuator. Refer to picture below for the correct orientation of spring. While holding the spring in the slot on the valve, place the actuator (with actuator plate) onto spring. Mount the actuator to the mounting bracket using the provided hardware. Before you fully tighten bolts make sure shafts are aligned (see photo). If the stock actuator shaft slot is in a different rotation than pictured below, simply turn the valve shaft slot on the muffler to line them up. Make sure all hardware is tight. **THE SPRING MUST BE SECURELY SEATED IN BOTH THE SLOT IN THE VALVE AND THE SLOT IN THE ACTUATOR!**

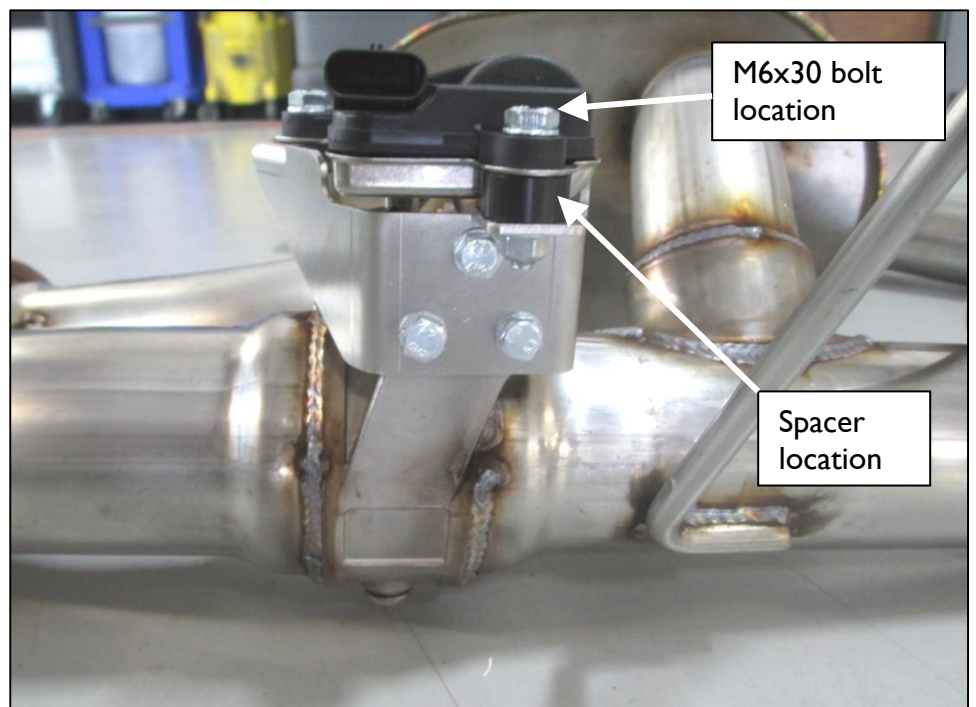
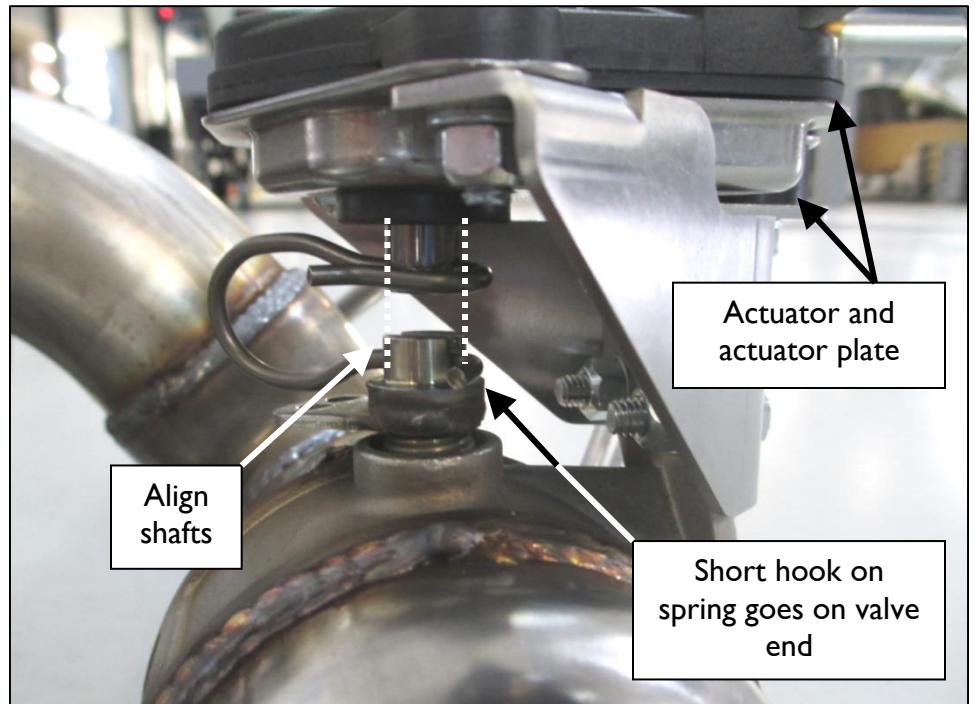
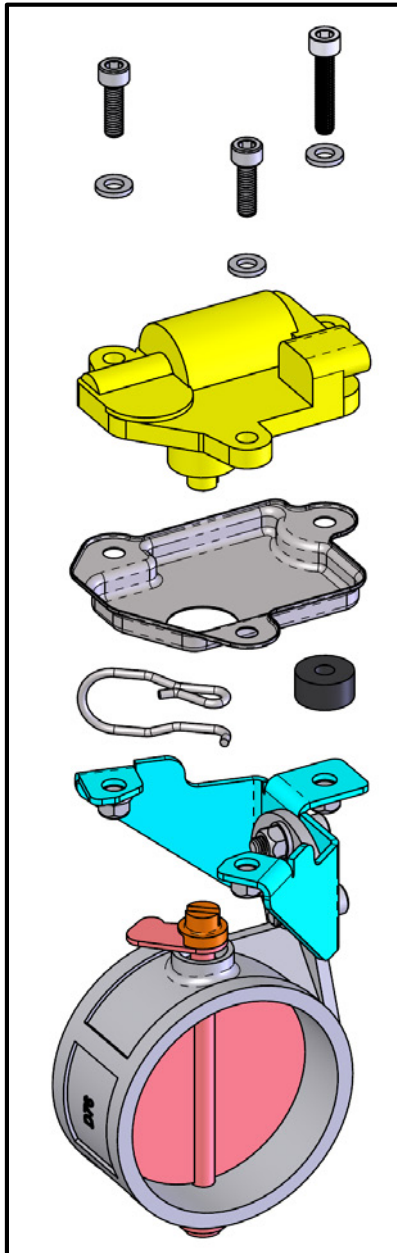

8. Install both stock hangers onto DINAN muffler as shown below.

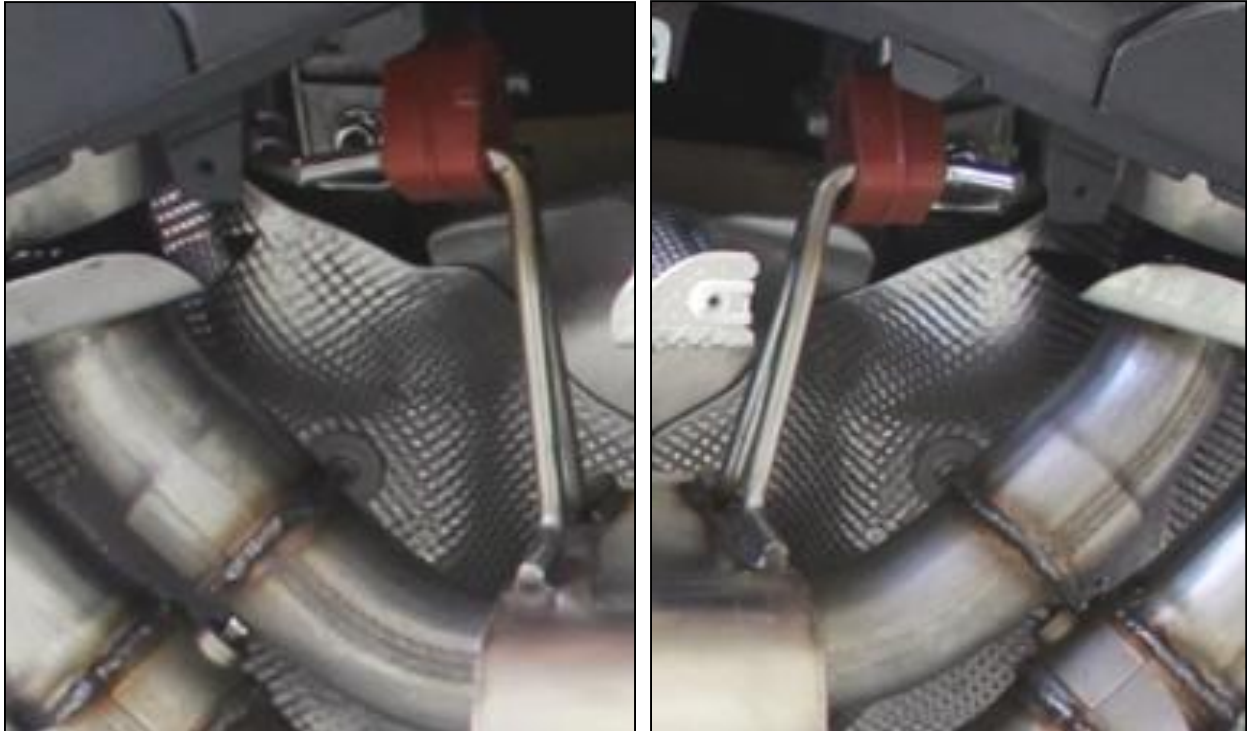

9. Place exhaust clamps provided in the hardware kit onto the inlet ends of the muffler. With DINAN exhaust secured on a jack or stand, rotate the muffler into place by positioning the outlet tubes into the tips attached to the bumper, then rotate the muffler inlet tubes up to mate to the stock tubes. Slide the clamps over the tubes and push the muffler forward against the ends of the stock pipes.

10. Mount both muffler hangers using the stock mounting nuts that were saved from removal of the stock muffler. Torque the nuts to **14 ft-lbs (19 Nm)**.

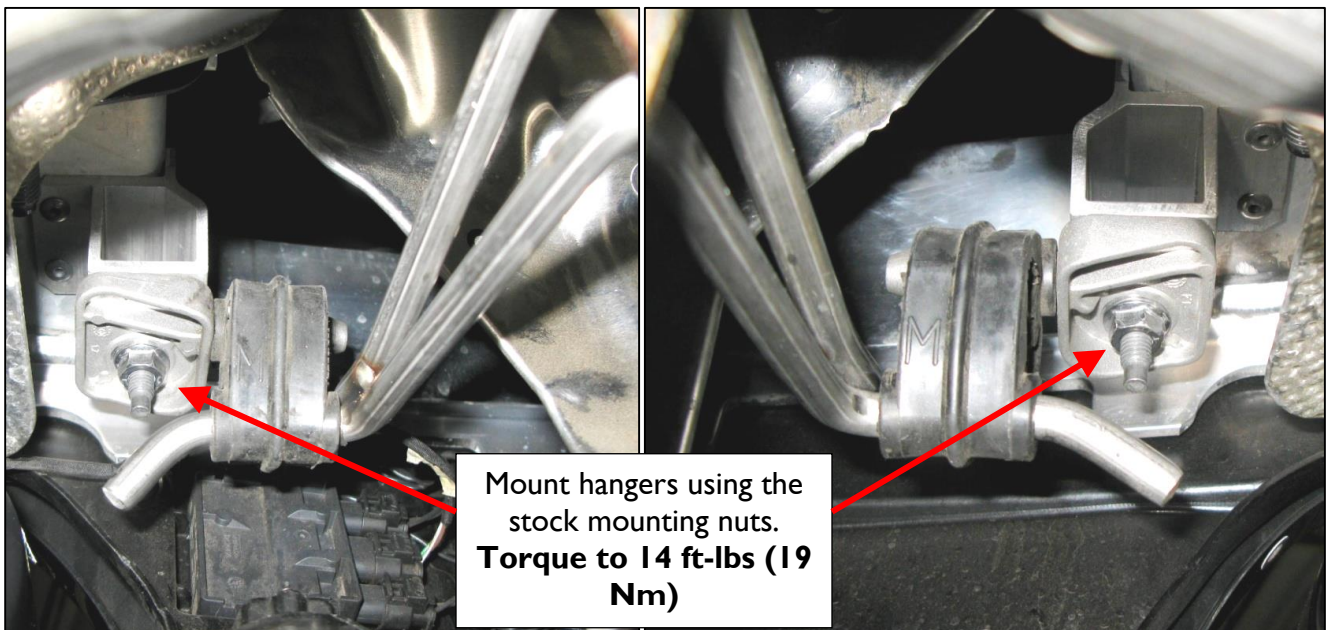
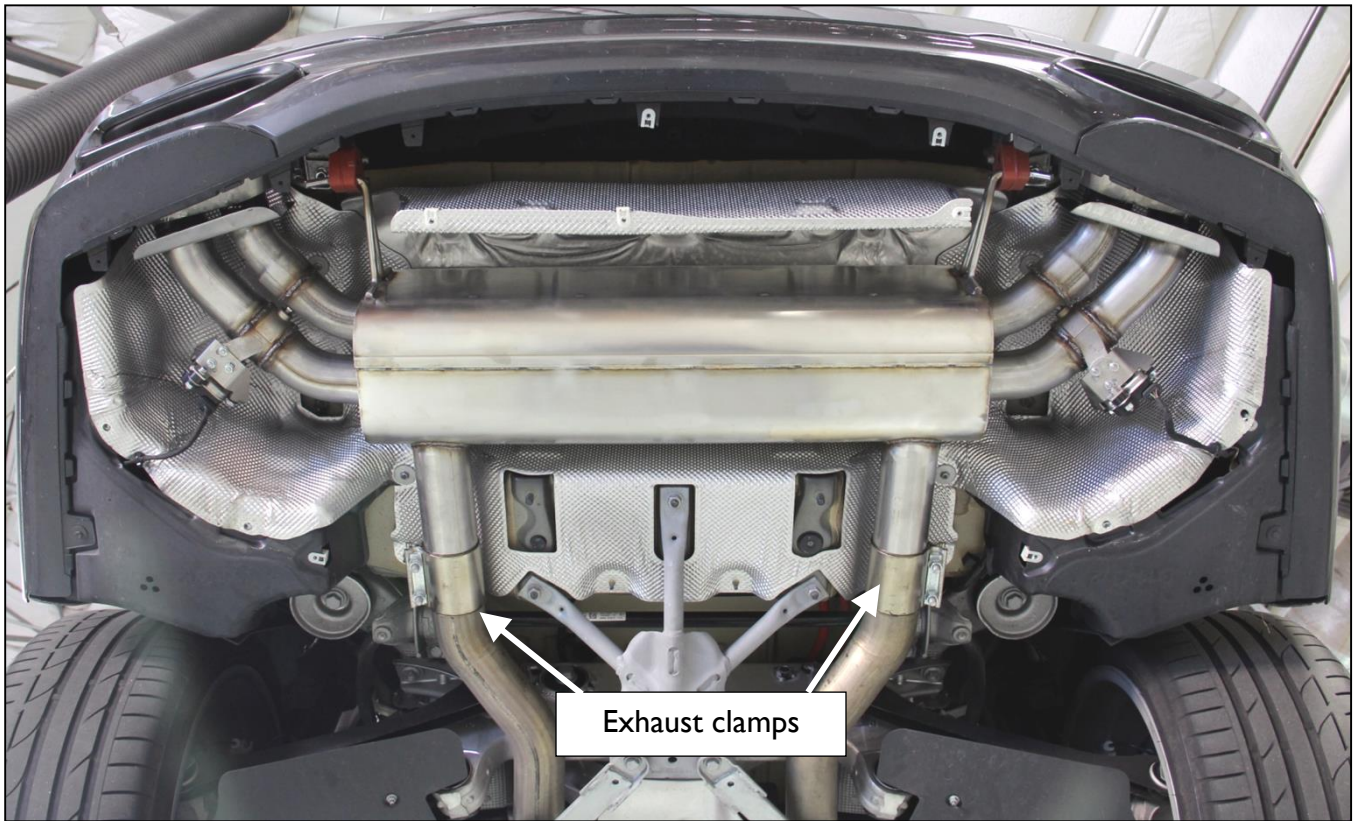

11. With exhaust clamp rotated as shown, torque clamps.
- Torque clamps with 10mm bolts to 45 Nm (33 ft-lbs)



M550i Tip & Valve Wire instructions

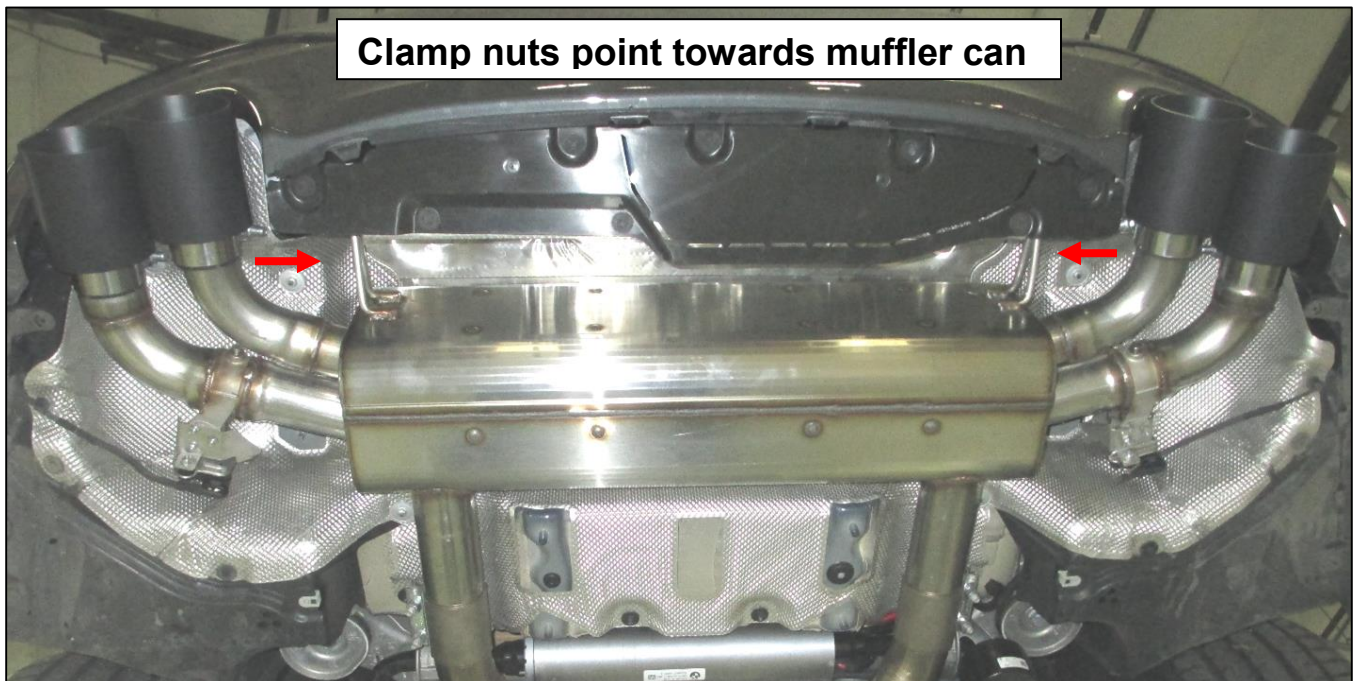

12. Verify there are 3 washers between the clamp and the nut.



13. The clamp must have the nut facing the muffler when installed on the car. Slip the clamp over the slotted flange at the back of the tip with the screw / nut on top, parallel with the Dinan logo, as shown below. Tighten the clamp until it is snug on the flange, while still allowing side-to-side rotation.

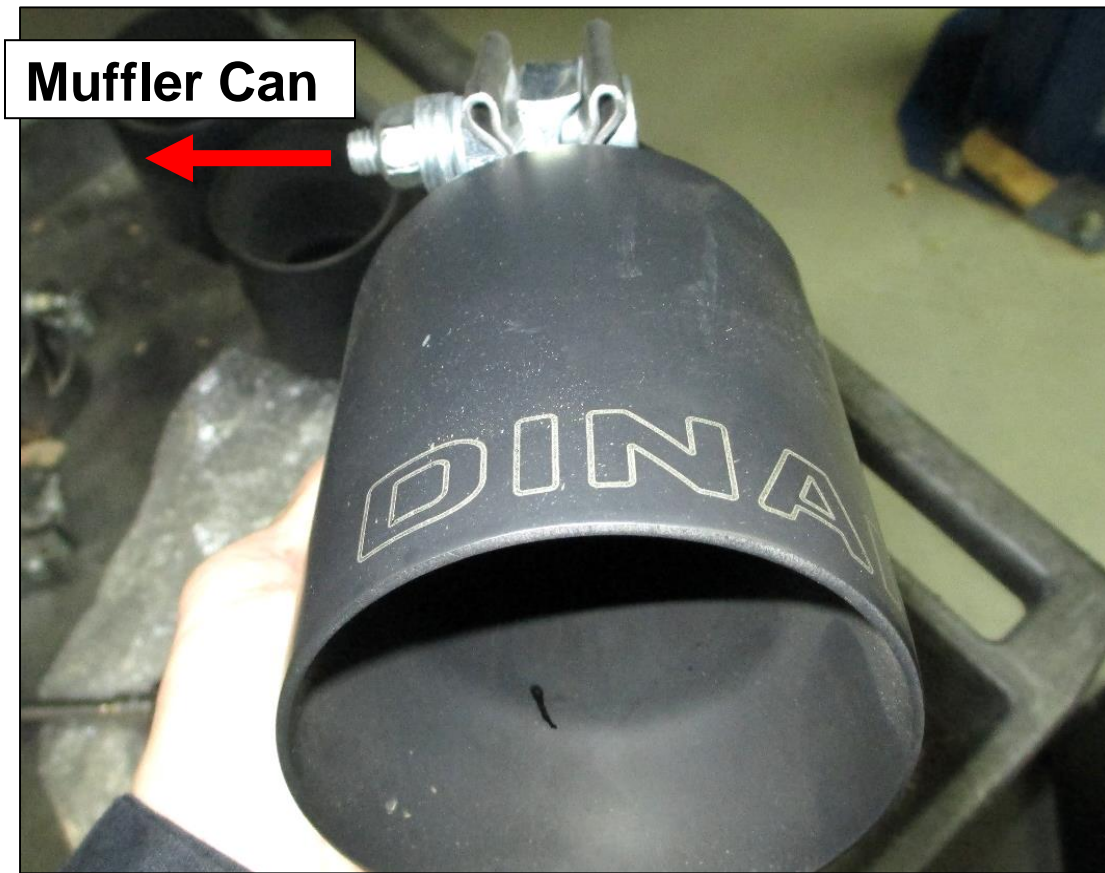

- Slide the tip over the outside outlet tube as far as it will go. Hold the tip steady, with a finger gap between Top Dead Center (the 1st "N" in DINAN") and the bumper. Use a 15mm socket to tighten until snug on the muffler, but still allows for final adjustment. Check to confirm there is approximately 1/8" protruding beyond the bumper at TDC (see below), then fully tighten.



15. Repeat for the inside tip on the same side of the car. Snug the clamp but still allow for adjustment. Use a straight edge to set the tip 1/8" beyond the bumper as shown. Then check the tip stagger – the ideal tip stagger is 1-3/8", but 1-1/4" is acceptable also. Regardless, the inside tip cannot protrude further than 1/8" beyond the bumper. Hold the tip in place and tighten. Follow the same steps for the other side of the car. Once complete, make sure the tip stagger is as close to even on both sides as possible, and one finger should be able to pass between the top of the tips and the bottom of the bumper.

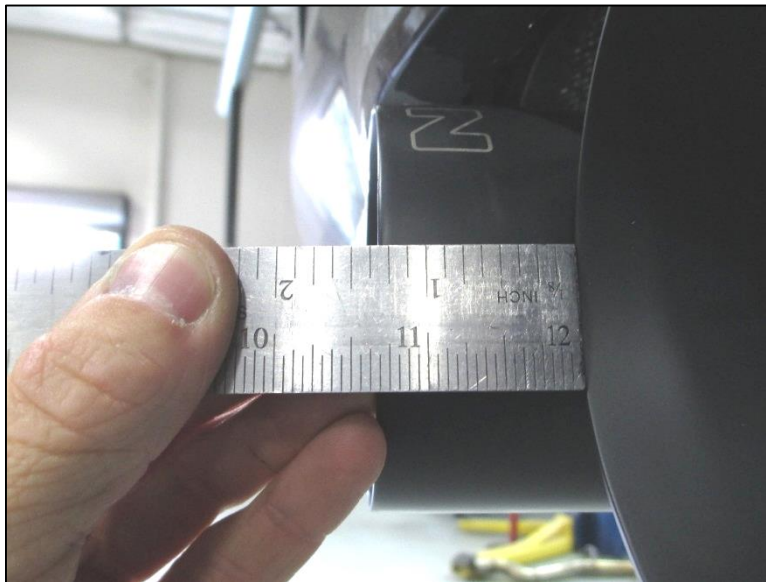
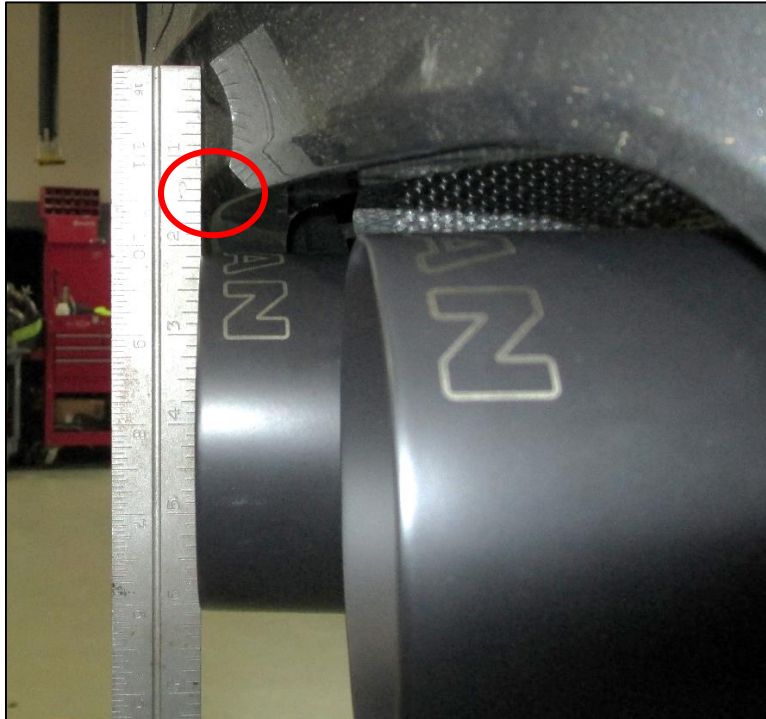

16. Check the exhaust tips for proper bumper clearance and proper alignment.
17. When all the tips are installed, they should be even from side to side, and resemble the photos below.



18. Connect the exhaust valves. If the driver-side harness doesn't reach, you can cut off the factory zip-tie to extend it. Plug in the valve until it clicks, then install a new zip-tie to help support the wire up. Cut off the excess tail on the zip-tie.

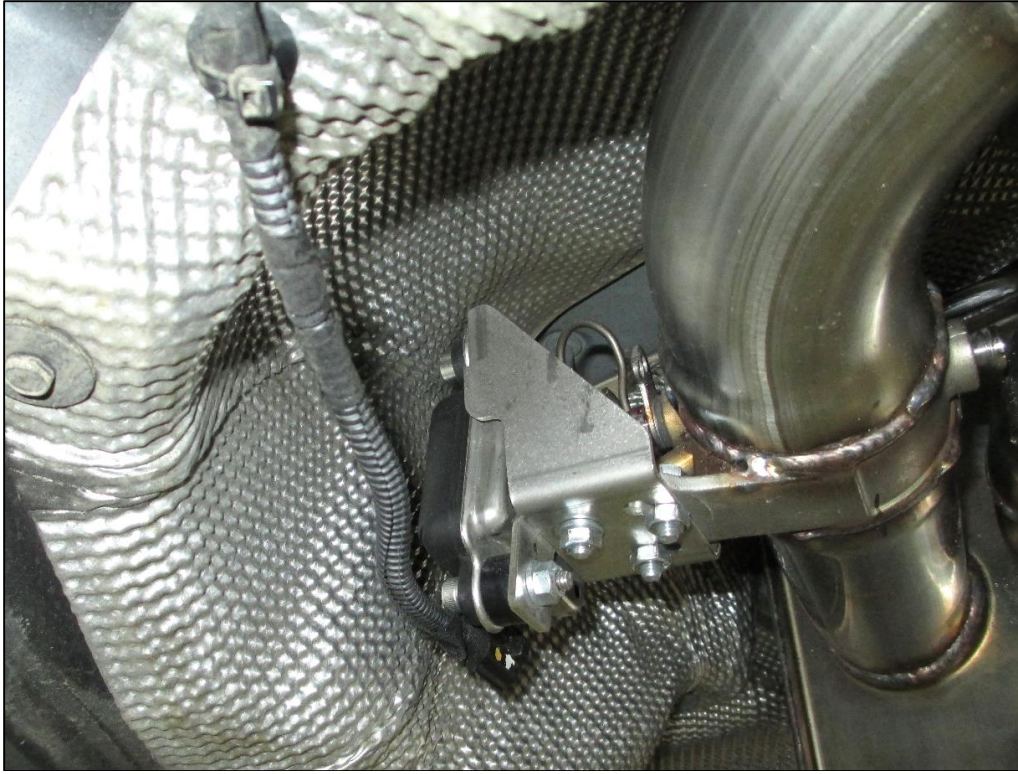

19. The passenger-side harness is too short. Again, cut the factory zip-tie. Pull the plug and route it through the valve motor mount bolts and plug it in as shown below. Reinstall a new zip-tie to prevent the harness from drooping. Cut off the excess tail on the zip-tie.

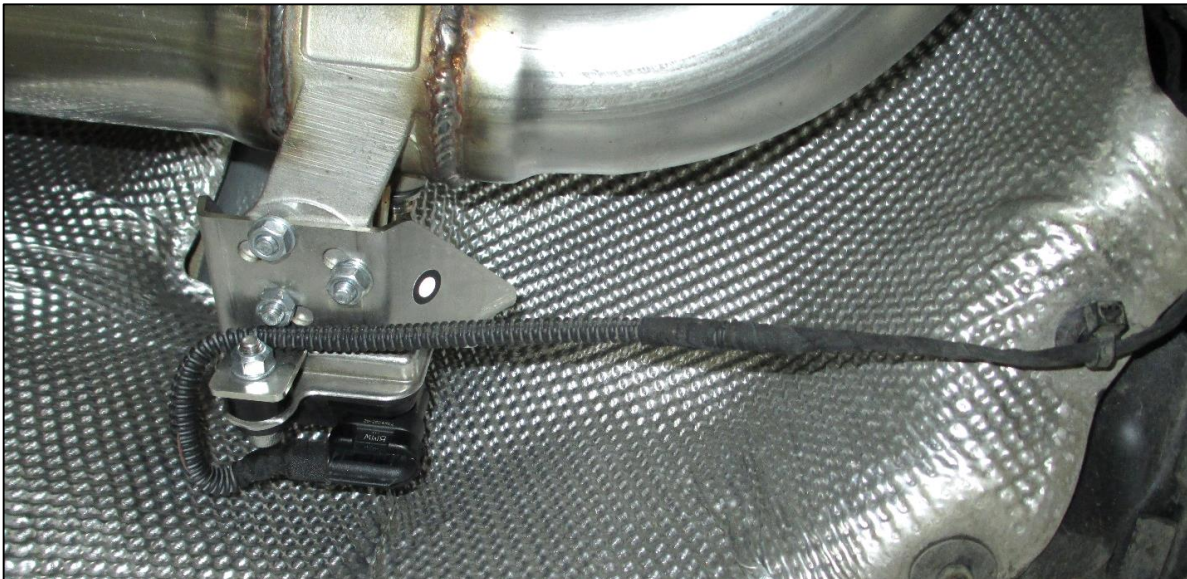

Enjoy your new DINAN exhaust!