



STAGE I COIL-OVER SUSPENSION KIT INSTALLATION INSTRUCTIONS

PART NUMBER R190-9131

APPLICATION: 2007-12 M3 (E90, E92, E93; EDC only)

Congratulations for being selective enough to use a Dinan Engineering Coil-Over Suspension Kit. We have spent many hours developing this kit to assure that you will receive maximum performance and durability with minimum difficulty in installation. Please take the time to read these instructions and call us if you have any difficulties during the installation.

NOTE: This kit is designed to work in conjunction with stock BMW EDC rear shocks in an E9x M3, which have 14mm threads. DO NOT use this kit for any other application!

DO NOT WORK ON VEHICLES SUPPORTED BY A JACK ONLY. USE SECURE JACK STANDS!

WARNING:

This is a **RACING-ONLY** part. This product is not covered by Dinan's normal 4-year 50k-mile warranty. Racing-only parts may also affect the **BMW** warranty and emissions warranty. Please contact your Dinan Sales Representative if you have further questions.

The components in this kit allows for increased suspension travel, enabling the vehicle to be lowered beyond what is normally possible with stock components, yet retaining a civilized ride.

**** However, this additional travel opens the possibility of tire to vehicle contact under heavy compression. Tire clearance must be carefully evaluated:**

- **During and after installation of this kit;**
- **After any ride height change;**
- **After any alteration to the original tire/wheel package.**

If you determine there is insufficient clearance, the vehicle must be raised, or safety will be compromised! Dinan is not responsible for any damages or injury!

INSTALLATION NOTES:

Dinan's target bumpstop clearance measurements are as follows:

	Bumpstop Clearance (in.)
Front	0.75"
Rear	0.88"

The above values were developed for a vehicle with the following specifications:

- 19" x 9.5" front wheels with 275/30-19 Michelin Pilot Super Sport tires
- 19" x 10.0" rear wheels with 295/30-19 Michelin Pilot Super Sport tires
- Dinan Lower Control Arm Monoball kit

If your vehicle is configured differently, you may alter the target values as needed for your situation. Note that proper bumpstop clearance is vital, and Dinan's values should be maintained if at all possible – even an 1/8" change will be noticeable! More bumpstop clearance improves comfort, but also has a negative effect on handling. Less bumpstop clearance results in a harsh ride. Bumpstop clearance is adjustable using the included packers, and/or by altering the ride height.

The front camber plates can be installed in one of two configurations:

- The "STREET" configuration allows for a camber range between -1.2° to -2.5°. Dinan recommends this arrangement for most situations, including moderate track use.
- The "RACE" setup allows for a front camber range between -1.9° to -3.2°. This amount of negative camber is very aggressive and is only recommended for TRACK USE ONLY. Using these values on the street will negatively impact tire longevity.

Please decide on one of these two configurations before proceeding with installation. The exact adjustment range available will vary slightly from car to car.

Three alignment setups are detailed further in the instructions.

- The conservative alignment is for street/highway use.
- The moderate alignment is for spirited "country road" use.
- The aggressive alignment is for track use.

PARTS LIST

Qty	Part #	Description
2	D100-0646	Front Springs (320 lb/in)
2	D101-0203	Race Spring (10" x 2.50" x 750 lb/in)
1	D110-0009	Rear Upper Shock Mount Kit; 14mm
2	D113-0005	Rear Spring Mount Assy.
2	D113-0012	Front Threaded Perch Assy.; M3
1	D113-0014	Endlink Mount Kit
1	D113-0017	E82/E9x Coil-Over Hardware Kit
1	D163-0023	Adj. Camber Plate Assy; Street Right
1	D163-0024	Adj. Camber Plate Assy; Street Left

FRONT INSTALLATION:

1. Remove front struts from vehicle per BMW procedure. Mark the struts with an "L" or "R" so they will not get mixed up. The struts will be reinstalled on the same side that they came out of.
2. Disassemble strut assemblies and set aside the upper mounts, springs, and spring pads. These will not be reused.
3. The Dinan swaybar endlink mounts will be installed in place of the stock pieces. Before proceeding, place a mark on the strut body at the middle of the stock swaybar mounting tab as shown. The endlink mounts are different from side to side. It is vital that the locations are properly marked so the Dinan mounts can be installed in the correct locations. Double-check your work! See photo.



4. Once the tab locations have been marked, remove the plastic caps from the top of the struts. These will not be reused.
5. Remove the stock endlink mounts from the struts by tapping them upward. They will release after sliding about 10mm or so. Set the stock endlink mounts aside – they will not be reused.

6. Locate the Dinan Endlink Mount Kit. This package contains two Dinan swaybar endlink mounts, and two 6mm flathead screws. The mounts are engraved “L” and “R” to indicate which side of the car they are for.
7. See figure below. Slide the mounts onto your struts as shown. At this time, you will slide them down as far as they will go (they will be raised to their final location during a subsequent step). Please verify that:
 - The “L” endlink mount is on the left-side strut, and the “R” endlink mount is on the right-side strut.
 - The gap in the Dinan mount is aligned with your mark as shown.
 - Do not tighten the 6mm flathead screws yet.

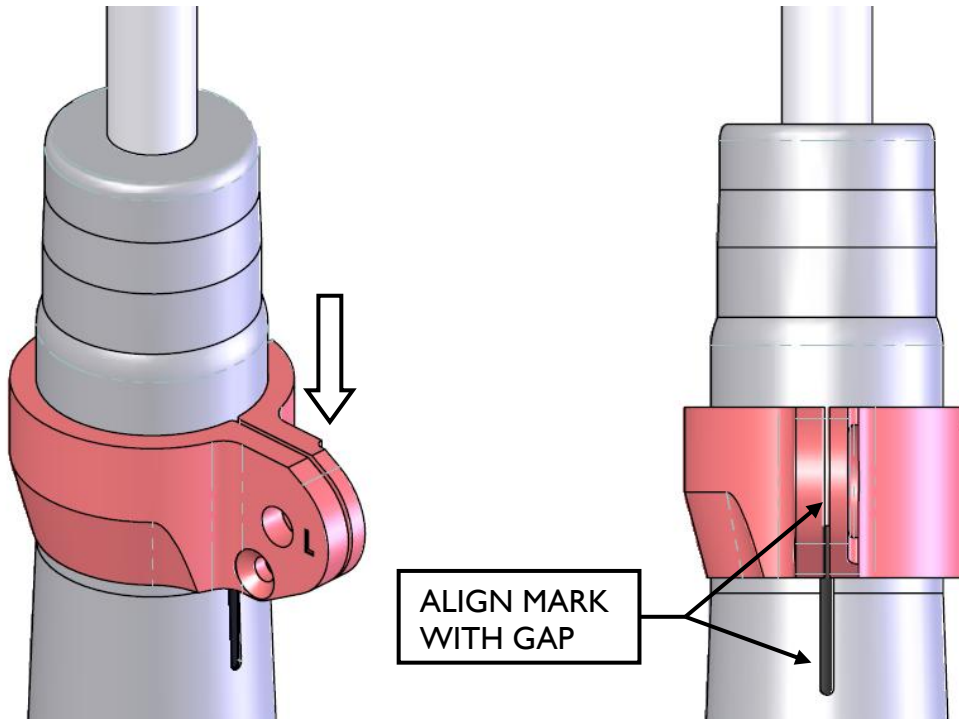

8. Locate the two Front Threaded Perch Assemblies. These are the same for left & right. Verify that the O-rings are properly located in the grooves as shown in figure.

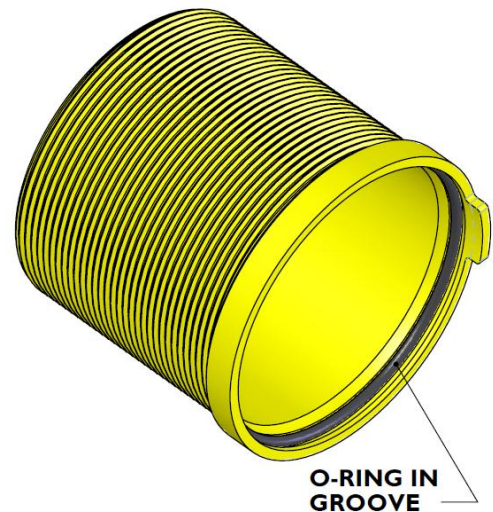

9. See figure below. Slide the threaded sleeves onto the struts as shown. Turn the sleeve to align the tab with the notch in the endlink mount. Note that the O-ring will make the sleeves spring upward slightly. This is OK.

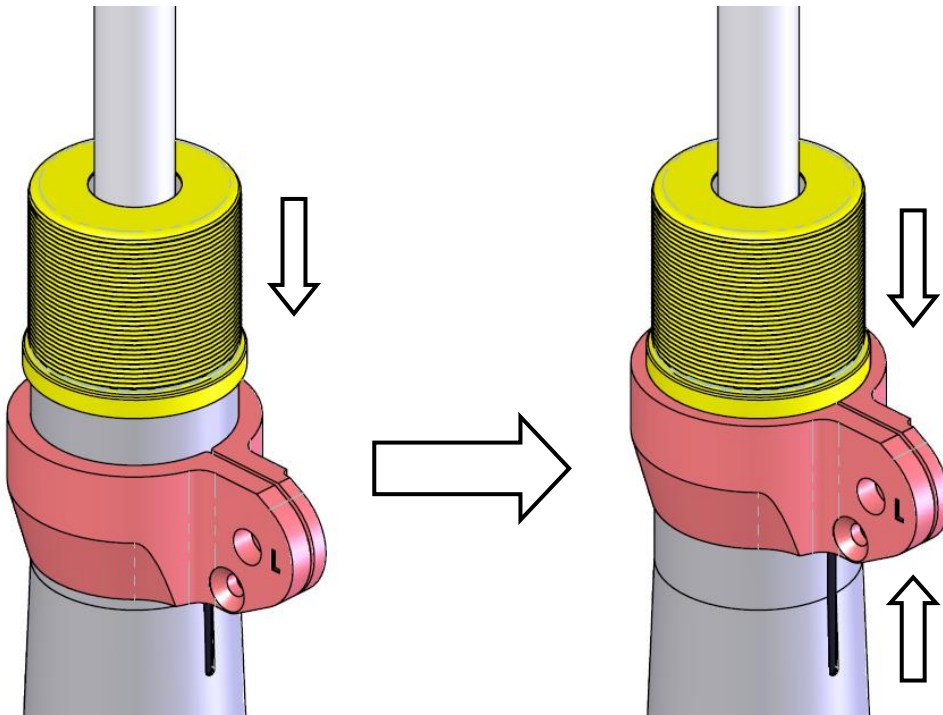

10. See figure above. While pushing down on the threaded sleeve, slide endlink mount straight upward until it just contacts the sleeve, and no further. This is the proper height for the endlink mount. Verify that the gap in the endlink mount is still aligned with your mark.

11. Install the 6mm flathead screw and torque to 95 in-lbs to lock the mount into place. When you release the threaded sleeve, it will spring upward and there will be a gap with the endlink mount. This is OK for now – the gap will disappear when the strut is loaded in the car.

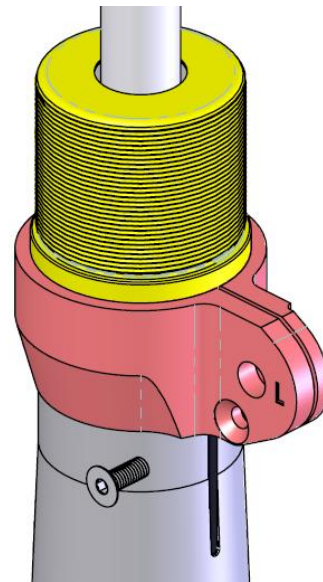

12. Install the spring perch and black plastic isolator disc (in Coil-Over Hardware Kit) as shown. Adjust the perch to its lowest setting. This will be the starting ride height setting, and should get you very close to Dinan's target bumpstop clearance measurement. Snug the 6mm screw to lock the perch into place.

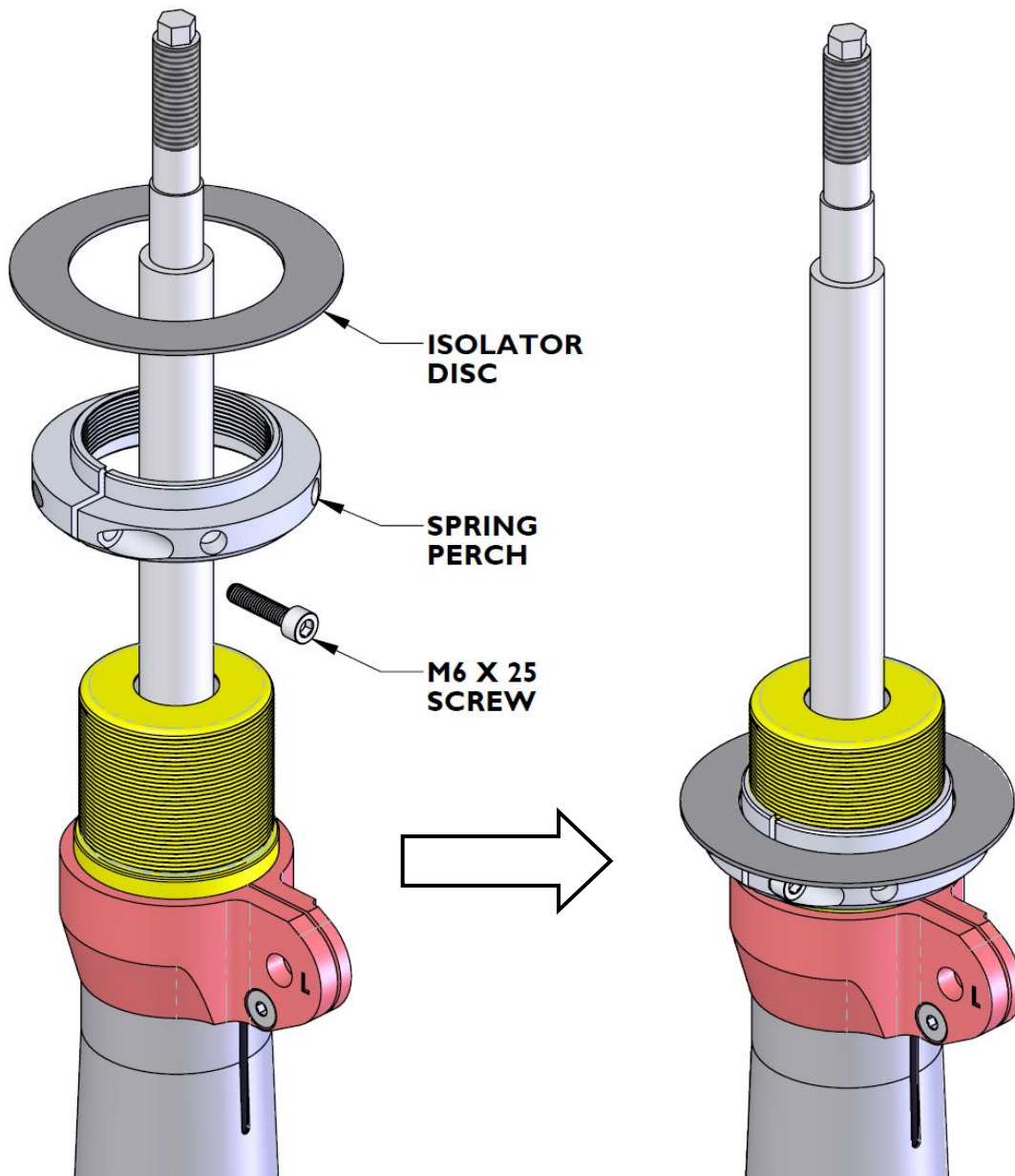

13. Install the rest of the front strut components as shown. Please note:

- The front bumpstops have the larger 18mm hole.
- Front packers have the larger 23mm hole.
- No packers are needed to start. Adjust this quantity as required, depending on your bumpstop clearance measurements (please refer to warnings at the beginning of these instructions).
- The Dinan camber plates are preassembled. To preserve the proper “stacking order”, do not cut the zip tie until you are ready to assemble the strut.
- If you are using the “Street” configuration:
 - The plate marked “STREET = RIGHT” goes on the right strut.
 - The plate marked “STREET = LEFT” goes on the left strut.
- If you are using the “Race” configuration:
 - The plate marked “RACE = RIGHT” goes on the right strut.
 - The plate marked “RACE = LEFT” goes on the left strut.

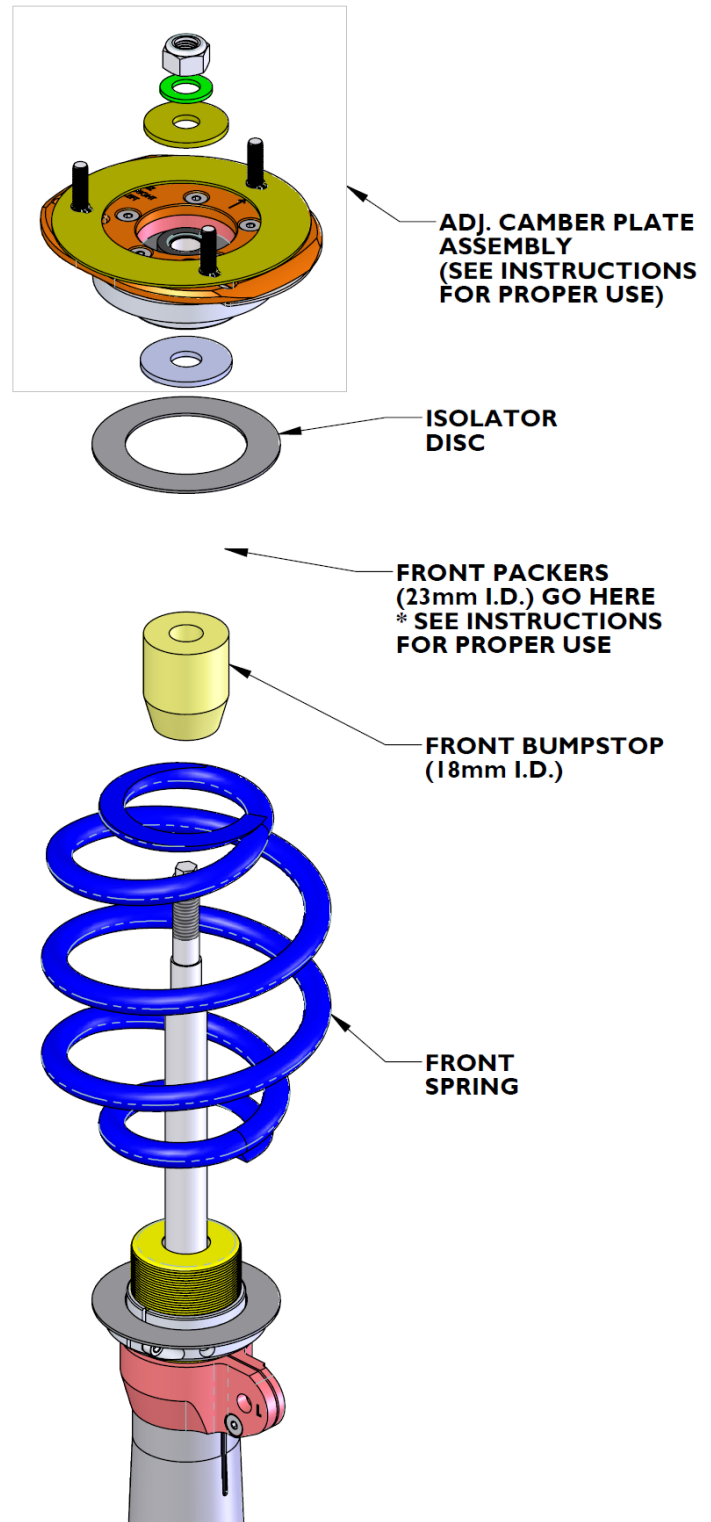

14. Install strut assemblies into vehicle, taking care to align the slots left-right to allow camber adjustment. If there are circlips on the camber plate studs, they may be left in place as they keep the assembly together while you install the struts into the car. These clips will not interfere with your ability to adjust camber.
15. IMPORTANT -- After attaching the swaybar link, retighten the 6mm flathead screws on the Dinan endlink mounts to 95 in-lbs.

REAR INSTALLATION:

16. Remove rear shocks and springs from vehicle per BMW procedure. Leave the lower spring pad in the control arm, as this will be reused.
17. Remove the stock upper spring pad and steel “pocket”. These will not be reused. The Dinan rear spring mount assemblies will be inserted directly into the chassis.
18. Disassemble rear shock assemblies per BMW procedure.
19. Install a rear bumpstop (with 15mm hole) onto the shock shaft. No rear packers (with 17mm hole) are needed to start. Adjust this quantity as required, depending on your bumpstop clearance measurements (please refer to warnings at the beginning of these instructions).
20. Install the Dinan upper shock mount per the separate instructions included in that kit.

21. Install the rear springs as shown.

Please note:

- Adjust the spring perch to its highest setting (for lowest ride height). This will be the starting ride height setting, and should get you very close to Dinan's target bumpstop clearance measurement. Snug the 6mm screw to lock the perch into place.
- The bottom of the rear main springs fit onto the stock lower spring pads. Rotate the main spring until the end of the coil best fits into the spring pad.

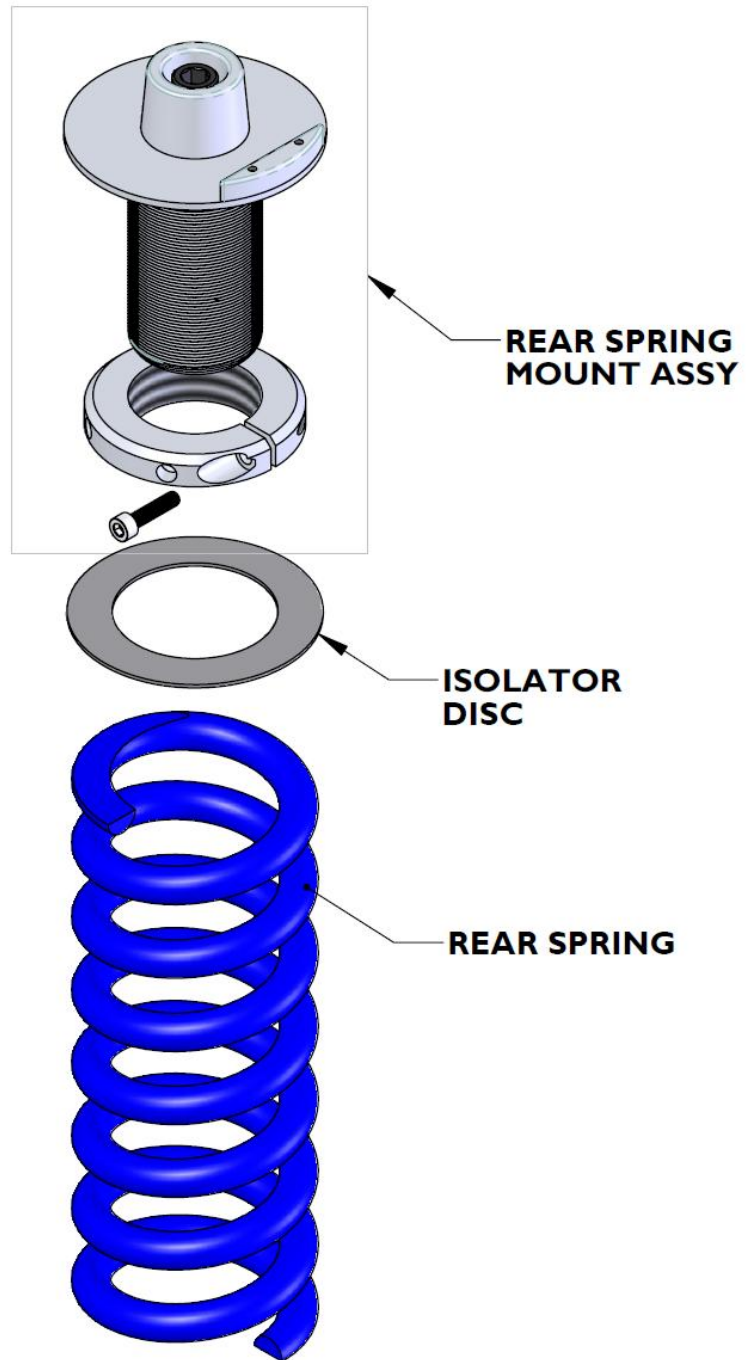

22. Install rear shock assemblies per BMW procedure.

SET RIDE HEIGHT & MEASURE BUMPSTOP CLEARANCE:

23. Take the car for a short test drive to settle the suspension.

24. Take center-of-wheel-to-fender measurements, and adjust the spring perches as necessary to obtain your target ride height. Make sure you roll the car forward & backward after each adjustment to settle the suspension. Tighten the spring perch screws once you obtain your target ride height.

25. Raise the vehicle. Examine the bumpstops and slide them all the way up as needed.

26. Tie a zip tie around each shock shaft. Trim the excess length of the zip tie so the "tail" does not interfere with the springs. Slide the zip ties all the way down until they contact the top of the strut or shock.

27. Lower the vehicle onto the ground, and roll it forward and backward to settle the suspension. Do not bounce the car! Bouncing the car will result in an erroneous bumpstop clearance measurement.

28. Raise the vehicle. The zip ties would have been pushed upward, and their new positions will show the bumpstop clearance at ride height.
29. At all four corners, measure the gap between the bottom of the bumpstop and the bottom of the zip tie. Dinan's target bumpstop clearance is 0.75" in the front, and 0.88" in the rear.
- If you have too much clearance – install additional packers as required until you achieve the target clearances.
 - If you have too little clearance – remove packers as required until the target clearance is attained. If there are no more packers to remove, then the car should be raised as needed.
30. An alignment must be performed after installation of this kit.

ALIGNMENT:

Notes:

- These alignment specifications are for a vehicle with full fuel tank and driver inside the vehicle.
- Set COLD tire pressures to 35 psi front and rear.
- Additional information is available in the following section "Understanding Alignment Settings". We recommend reviewing this section before finalizing the alignment.

<u>Conservative alignment:</u>		
<ul style="list-style-type: none"> • Recommended for street/highway use • Front swaybar adjustment (if available) = middle position • EDC position = soft setting 		
FRONT	Setting	Tolerance
Camber	-1.25°	± 0.1°
Caster	6.5°	± 0.5°
Total Toe	0.28°	± 0.07°
REAR		
Camber	-1.70°	± 0.1°
Total Toe	0.17°	± 0.08°

Moderate alignment:

- Recommended for spirited “country road” use
- Front swaybar adjustment (if available) = full stiff
- EDC position = middle setting

FRONT	Setting	Tolerance
Camber	-1.50°	± 0.1°
Caster	6.5°	± 0.5°
Total Toe	0.14°	± 0.07°
REAR		
Camber	-1.85°	± 0.1°
Total Toe	0.17°	± 0.08°

Aggressive alignment:

- Recommended for track use
- Front swaybar adjustment (if available) = full stiff
- EDC position = stiff setting

FRONT	Setting	Tolerance
Camber	-1.75°	± 0.1°
Caster	6.5°	± 0.5°
Total Toe	0.00°	± 0.07°
REAR		
Camber	-2.00°	± 0.1°
Total Toe	0.17°	± 0.08°

UNDERSTANDING ALIGNMENT SETTINGS & VEHICLE SETUP

Dinan has always been famous for creating a high performance suspension that not only handles great, but also rides great. This can be accomplished with proper engineering. However, to do this it is important to set the car up correctly, and understand proper alignment and set up of a Dinan vehicle. No suspension will work correctly without proper setup. The settings contribute as much to handling as the components themselves.

Pull:

A pull is a front caster or camber alignment issue. Toe cannot cause a pull; it can only cause the steering wheel to be crooked.

A car pulls towards the side of most positive camber or least positive caster. The severity of pull caused by camber and caster is not equal -- a $\frac{1}{2}^{\circ}$ of camber pull is equivalent to about 1° of caster pull. It is possible for the camber and caster to be off in opposite directions, and the car will still track straight.

Example – A car with the following alignment will track straight:

LF Camber: -0.50°	RF Camber: -0.75°
LF Caster: $+7.0^{\circ}$	RF Caster: $+6.5^{\circ}$

A defective tire can also cause a pull. This can be diagnosed by temporarily swapping the front tires and checking to see if the pull follows the tire.

Tolerances:

Our technical support lines receive frequent calls regarding a complaint about a pull on a recently-aligned car. Technicians always report that "...the car's alignment measurements are within the BMW or Dinan specified ranges, as indicated by a green display on the alignment machine..."

The measurements are allowed to be on the positive or negative limits, but they must be equal from side to side. A side-to-side discrepancy will result in a pull. An alignment range will normally be $\pm 0.5^{\circ}$. That does not mean that one side can be at $+0.5^{\circ}$, and the other side at -0.5° , or else the car will have a considerable pull, even though the measurements are "within tolerance".

Finer Points of Alignments:

Before aligning any car, check the tire pressures and adjust as necessary. In addition, the car must be driven on a straight smooth road with an average crown before you put it on the alignment rack. This will allow you to evaluate if the car has a pull, so that when you see the measurements, they will make sense.

Road Crown:

Roads are designed with a crown for water drainage. Without compensation, cars will naturally want to drift towards the side of the road (left-hand drive cars will tend towards the right, and right-hand drive cars will tend to the left). As a result, it is good

practice to set up the alignment with a little compensation for road crown. This is done by setting the side closest to the center of the road with a little more positive camber, or a little less positive caster, than the side closest to the side of the road. It requires approximately 0.1° to -0.2° more positive camber, or 0.2° to -0.4° less caster, to compensate for road crown. Don't adjust aggressively if the car didn't pull during your test drive.

Example – the following variances from side-to-side will usually make a car go straight on most left-hand drive roads:

LF Camber: -0.80°	RF Camber: -1.00°
LF Caster: +7.0°	RF Caster: +7.0°

Or...

LF Camber: -1.00°	RF Camber: -1.00°
LF Caster: +6.6°	RF Caster: +7.0°

Tire Wear:

Excessive tire wear can be caused by camber or toe.

- Too much positive camber will wear the tire on the outside, and too much negative camber will wear the tire on the inside.
- Too much toe-in will wear the tire on the outside, and too much toe-out will wear the tire on the inside.

When a tolerance is given for an alignment setting, it is because each driver operates their car differently, and you must evaluate the customer's needs when performing an alignment. The best way to do this is to examine tire wear.

- A very aggressive driver, one that drives curvy roads frequently, or who frequently participates in track days will wear the tires on the outside edge.
- Conversely, someone who drives sedately or spends much time on the highway in a straight line will likely wear tires on the inside.

If a camber range is given, the aggressively driven car should be setup on the negative side, and the sedately driven car should be setup on the positive side of the allowed range.

Do not be fooled by the fact that the customer is purchasing a high performance suspension. Often people purchase a suspension just for the look of a lowered car, and not because they drive fast. Their tire wear will tell the story.

Wheels & Tires:

Wheels and tires will have a dramatic effect on your car performance. Often people create a tire and wheel combination that has a detrimental effect on the car's performance. The biggest mistakes made are too big of a tire width difference front-to-rear, or too large of a tire diameter.

40mm smaller front tires:

If you have 40mm smaller front tires than the rear, you will have terminal under-steer, front end plow, or push that you just can't get rid of. In other words, the car will just

not turn well when going fast. If you drive the car fast, you will punish the front tires so much that they will overheat the compound and actually increase under-steer as the tires get older.

30mm smaller front tires:

If you have 30mm smaller front tires than the rear, you will have noticeable under-steer, probably more than desired. This is the typical factory M-car set up, designed to make enough under-steer to keep you out of trouble. If you drive the car fast, you will punish the front tires a little more than the rear, which will overheat the compound and actually increase under-steer slightly as the tires get older. This is the safest combination.

20mm smaller front tires:

If you have 20mm smaller front tires than the rear, you can achieve a well balanced car. This is the typical Dinan configuration, designed to make it possible to achieve under-steer or over-steer at will, based on your set up and driving style. If you drive the car fast, you will punish the tires equally, so the car will remain balanced as the tires get older.

10mm smaller front tires:

If you have 10mm smaller front tires than the rear, you can achieve a well balanced car. This will make it possible to achieve under-steer or over-steer at will based on your set up and driving style. If you drive the car fast, you will punish the rear tires slightly more than the fronts, and the car will develop a slight over-steer as the tires gets older. This is only true of a high powered car because of its ability to “turn the rear tires over”. A low-powered car will maintain good balance, and the rear tires will not degrade more quickly than the fronts.

Equal sized tires front & rear:

If you have equal sized tires front and rear, you can achieve a well balanced car. This will make it possible to attain under-steer or over-steer at will, based on your set up and driving style. You will punish the rear tires a lot more than the fronts, and the car will develop a significant over-steer as the tires get older. This is more true of a high powered car because of the ability to “turn the rear tires over”. It’s OK to install a smaller rear tire to balance the car. Oftentimes people put on a larger rear tire, when a smaller one will actually make the car handle better.

Ride Quality:

The largest contributor to poor ride quality is ride height, and not stiff springs. The bump stop should have at least 1/2” clearance, (preferably 3/4”) in the front, and 3/4” to 1” in the rear. If you are installing a coil over suspension, please adjust the ride height accordingly.

Scrub:

Scrub is the distance between the centerline of the tire, and the geometric centerline of the outer ball joint or attachment location in the suspension. As you put wider wheels and tires on your car, the scrub increases. Increased scrub will cause the car to dart around or follow ruts in uneven pavement. This is because the leverage of the scrub will cause more bushing distortion in the suspension.

This darting can be reduced and the car made more stable by stiffening the bushing in the suspension. Dinan has bushing kits, monoballs, toe links, and high performance limited slip differentials designed to make your car more stable and responsive. These systems are highly recommended when larger wheels and tires are installed on your car.

Tire Clearances:

Due to differences in construction, different brands of tires are different widths even if they are marked with the same size. With a coil-over track suspension that has a large range of ride height adjustment and camber settings, it is very easy to get larger-than-stock wheels and tires to rub. This is not just on the fender lip, but also on the inside plastic fender liner, and the top of the fender well from the car being lowered excessively. If you have larger than stock wheels, then suspension adjustments, or rolling & trimming of fender lips may be required (at additional expense) to ensure clearance. Oftentimes rubbing isn't evident until the car is loaded or driven very hard. Multiple repair attempts may be required. Choosing larger diameter wheels (like 20" when a car was originally equipped with 19") will compound the problem tremendously. It may be necessary to raise the ride height slightly to prevent the tires from rubbing on the top inside of the wheel wells.

Tire Pressures:

Most people run too much air pressure in their tires for maximum grip. More pressure does not mean more grip. Most low profile high performance tires will make maximum grip between 36-40 psi hot. What this means is you drive your car aggressively on your favorite winding road or race track, immediately jump out of the car and measure the pressures before the tires have started to cool. The cold pressure can then be determined after the car sits over night and the tires have cooled to ambient temperature. Because of the extreme temperature reached on a race track, the proper cold pressures for track use will be lower than the cold pressures for street use.

Track Adjustments:

Camber:

Over-steer is when the car gets sideways equally when cornering hard. Under-steer is when the car plows in the front end and does not want to turn. Different chassis set up and tires will alter the handling characteristics of your car. To properly set up your coil over suspension you will need an experienced racing driver to determine the balance of your car with the tires you have chosen.

The end of the car that is stiffest does the most amount of work and therefore loses traction first.

- So if your car over-steers you would stiffen the front bar.
- If it under-steers then you would soften the front bar.

A stiffer bar does not mean a better handling car. The bar should be adjusted for a proper under-steer, over-steer balance.

Another way to adjust the balance of your car is camber. More negative camber usually means more grip in a street car. This is because most street cars run a more positive camber setting to promote good tire wear when driving in a straight line on the freeway. If your car over-steers, you can add negative camber to the rear. If it under-steers you can add negative camber to the front. Don't get too carried away – most

cars can tolerate between -0.5° and -1.5° of camber on the front, and between -1.4° and -1.8° of negative camber in the rear, before excessive tire wear is experienced. The more aggressively you corner, the more negative camber can be tolerated. If it is a dedicated track car, then between -3.0° and -4.5° in the front, and between -2.0° and -2.5° in the rear is OK. This is for a car that is trailered to the track, and never to be driven on the street.

Toe:

Toe can be adjusted to improve grip as well.

- Toe-in the front will reduce front grip and make a car under-steer (or reduce over steer).
- Toe-out will make it over-steer (or reduce under-steer).
- Toe-in the rear will add grip and increase under-steer (or reduce over-steer)
- Toe-out in the rear will make over-steer and a very unstable car

Compensating for Camber and/or Grip with bar settings, springs, or shocks:

As you add more negative camber and toe out in the front, the car will gain a lot of front grip, which causes the car to roll more and be more responsive. This increased roll and response will make the car hard to control and it will need more support. Support can come from a stiffer front bar, spring, or shocks. If you do not want to stiffen up the car, then you will need to be more conservative with the alignment settings.