



## Free Flow Exhaust Installation Instructions

**PART NUMBER D660-4602**

APPLICATION: 2001 325i, ci, xi, touring, convertible  
2001 330i, ci, xi, convertible

---

Thank you for purchasing a Dinan High Performance Muffler! Some mechanical skill is required to install this muffler. If you are not familiar with this procedure, we strongly recommend that you arrange for a qualified BMW repair facility to perform this installation.

### **INSTALLATION:**

- I. Hold the new Dinan muffler up under the stock muffler. Line up the center of the bolt holes on the new muffler mounts with the bolts on the stock muffler hangers. The new Dinan Muffler Pipes are a slip fit over the stock pipes. You will need to have enough overlap to seal well (2.0" – 2.5"). The stock pipes will need to be cut at a point 2.0" to 2.5" longer than where the new Dinan muffler pipes end. Mark the Pipes at this point and recheck the line up with the muffler hangers. Cut the pipes at this point. . (Be careful not to cut into any surrounding parts.)

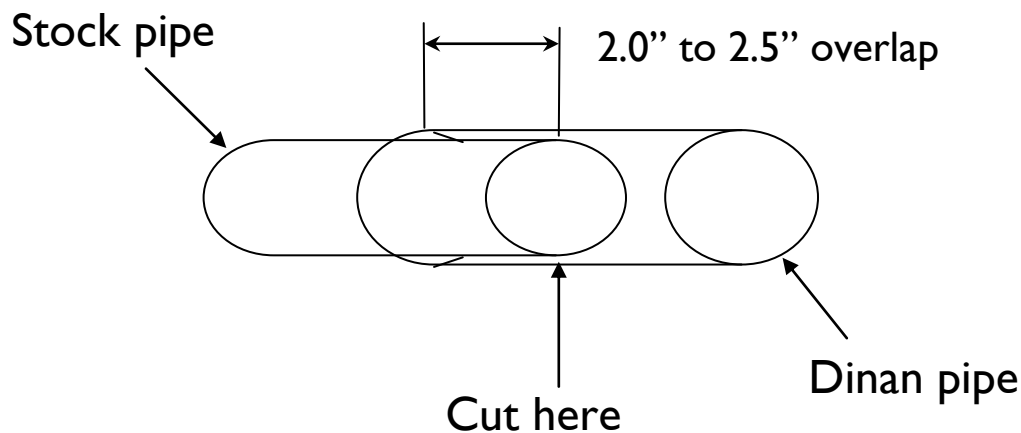

2. Remove the stock muffler by detaching the rubber hanger from the car. Each of the two hangers is held in place with two 13mm nuts.
3. Plug the vacuum hose that goes to the exhaust flap on the muffler with the supplied plug. Wire-tie the hose to itself in a loop so it is not hanging down.  
**Note: You must plug hose or you will set an OBD-II Fault.**

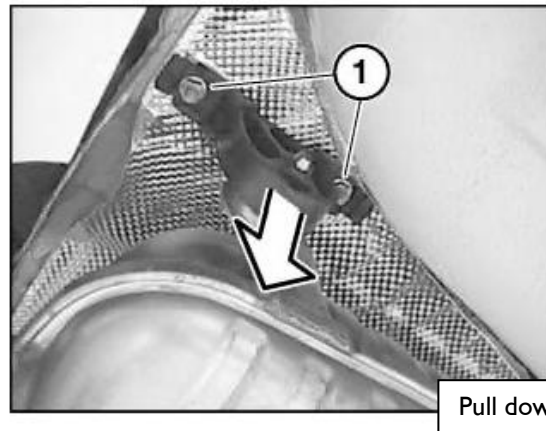
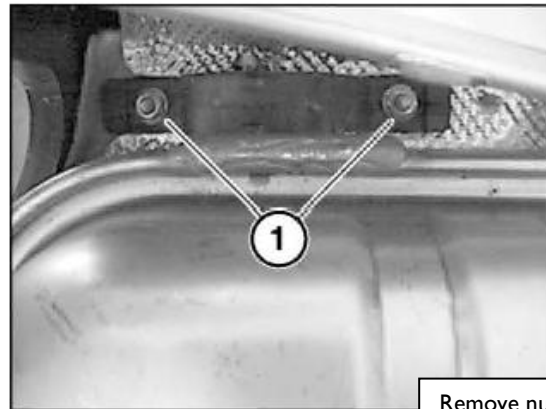
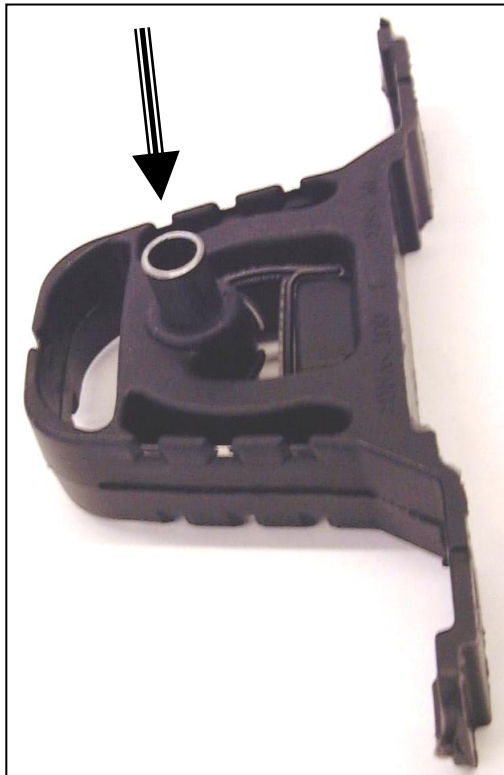

4. Insert the two metal sleeves into the stock rubber hangers. Note: To aid insertion, a silicone or similar non-petroleum based lubricant may be used.
5. Install the hangers onto the Dinan muffler using the supplied hardware. Place the washers under the lock nuts and tighten the hangers in the middle of the slot.



6. Deburr the inside of the stock exhaust on the car and clean the outside surface to ensure a good seal.

At this point, determine whether the Dinan muffler will be clamped or welded.

7. Slide the Dinan muffler over the stock tube before placing it in position. It may be necessary to rotate the muffler or slightly pull on the bumper cover.
8. Install the muffler by reattaching the hangers into the car.
9. Visually inspect the muffler. Check for ½” clearance in all areas. Make sure the polished tips are centered. The Dinan muffler brackets are slotted to allow some adjustment.

#### Clamping Only

Tighten the clamp to 45 ft.-lbs.

#### Welding Only

**\*A MIG or TIG welder with stainless steel wire must be used.** The clamp alone may be removed by cutting the tack weld (revealing four slots underneath) **or** cut off the entire clamp assembly flush with the back of the clamp.

Clean the surface of the stock exhaust tube where it is going to be welded. Tack-weld the Dinan muffler onto the factory exhaust tube in at least three places. Then weld all the way around the tube. Fill in all four slots if they are present.

Happy Motoring!