



Free Flow Exhaust Installation Instructions

**PART NUMBER
D660-0056-BLK**

APPLICATION: 2016 F87 M2

Thank you for purchasing a Dinan High Performance Muffler! Some mechanical skill is required to install this muffler. If you are not familiar with this procedure, we strongly recommend that you arrange for a qualified BMW repair facility to perform this installation.

INSTALLATION:

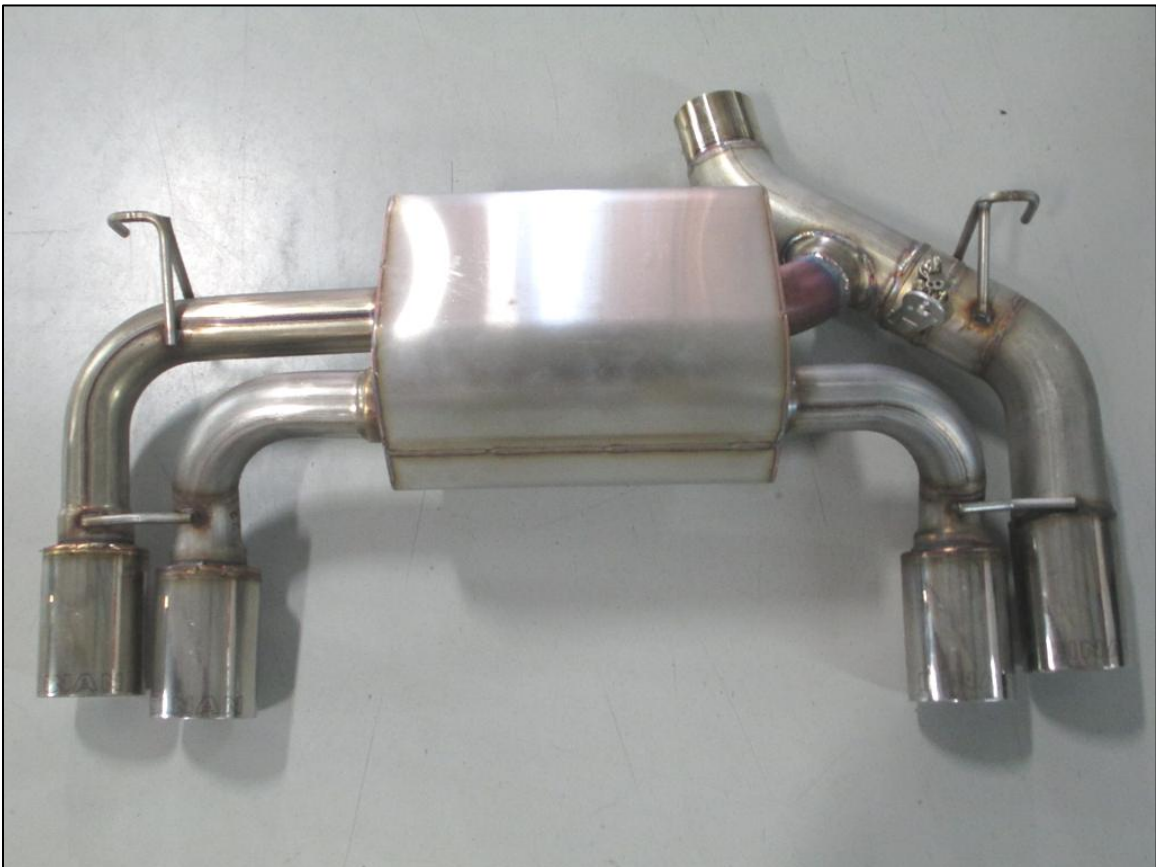

1. Disconnect the battery using BMW factory procedures (make sure the car is asleep).
2. Disconnect the valve actuator.

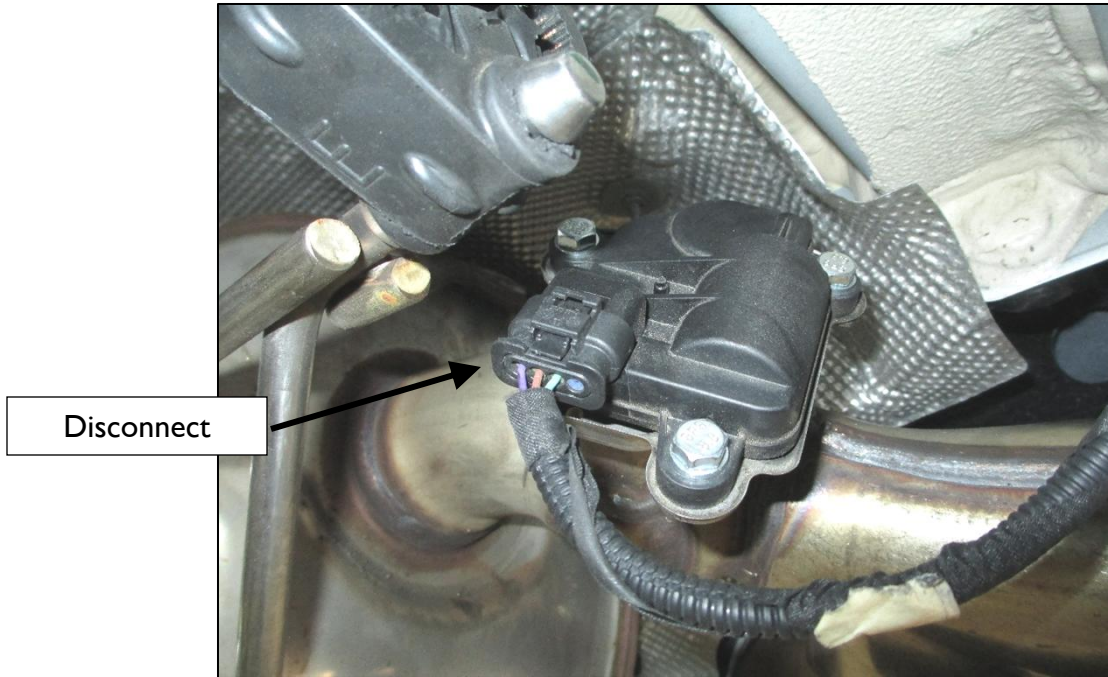

3. Support the muffler securely with a jack or a stand, then cut the stock muffler at the BMW cut dimple location as shown in **Figures 1 & 2**. Before cutting the stock muffler, hold DINAN muffler underneath stock muffler to verify the stock pipe will not be cut too short!

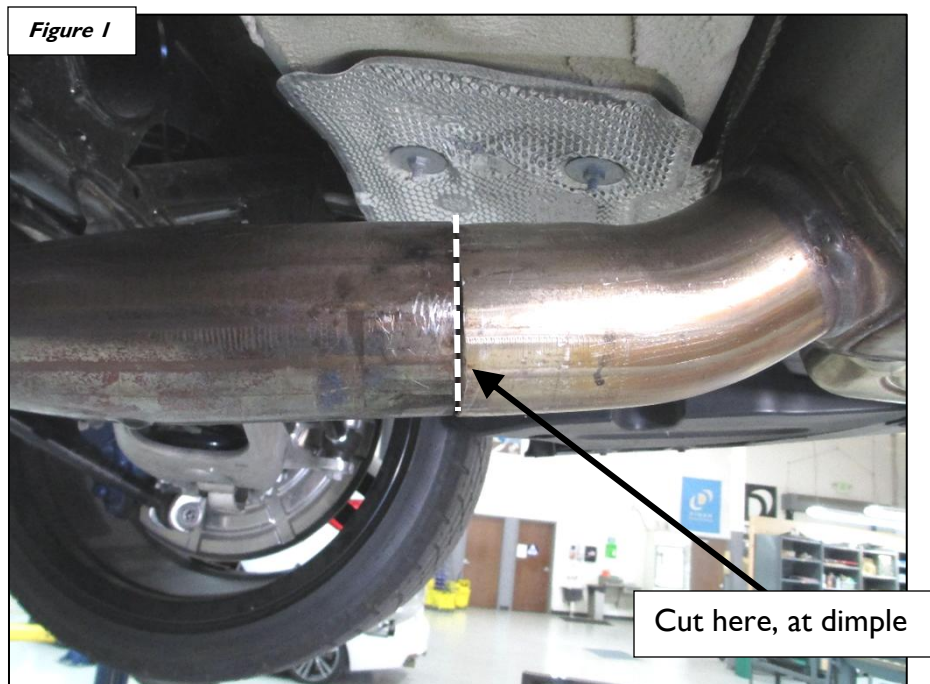

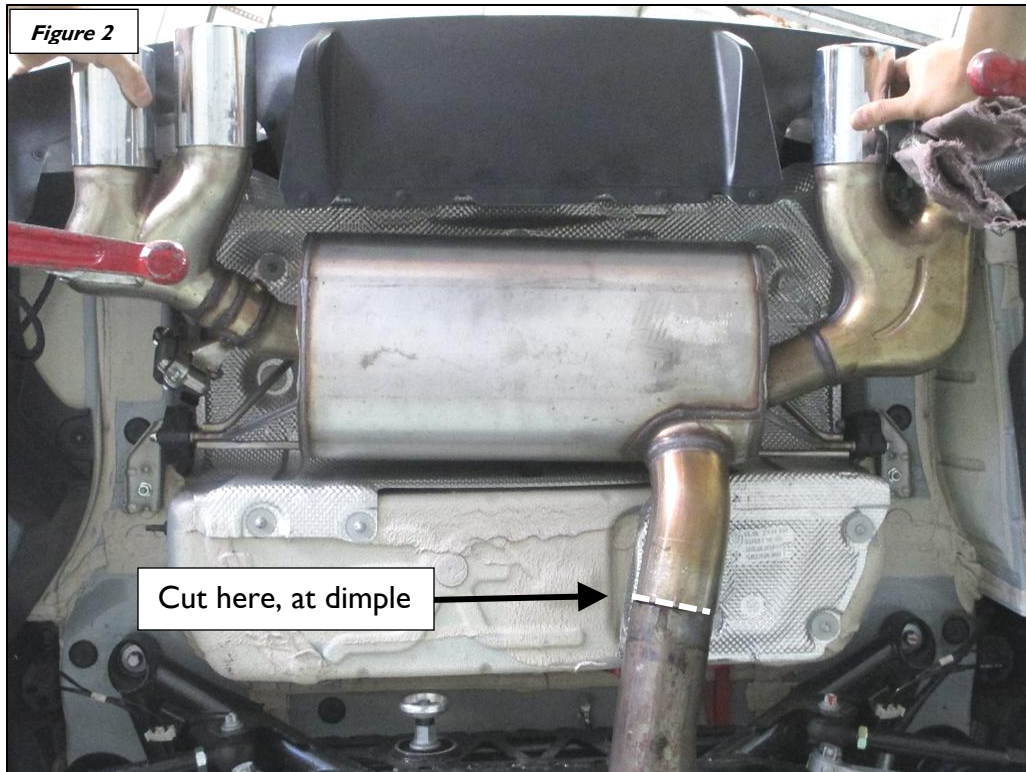

4. With the stock muffler fully secure and supported on a jack or stand, remove the hanger nuts as shown (SAVE THESE NUTS FOR INSTALLATION OF DINAN MUFFLER!), then remove stock muffler. Be sure exhaust valve actuator is disconnected before finally removing the muffler.

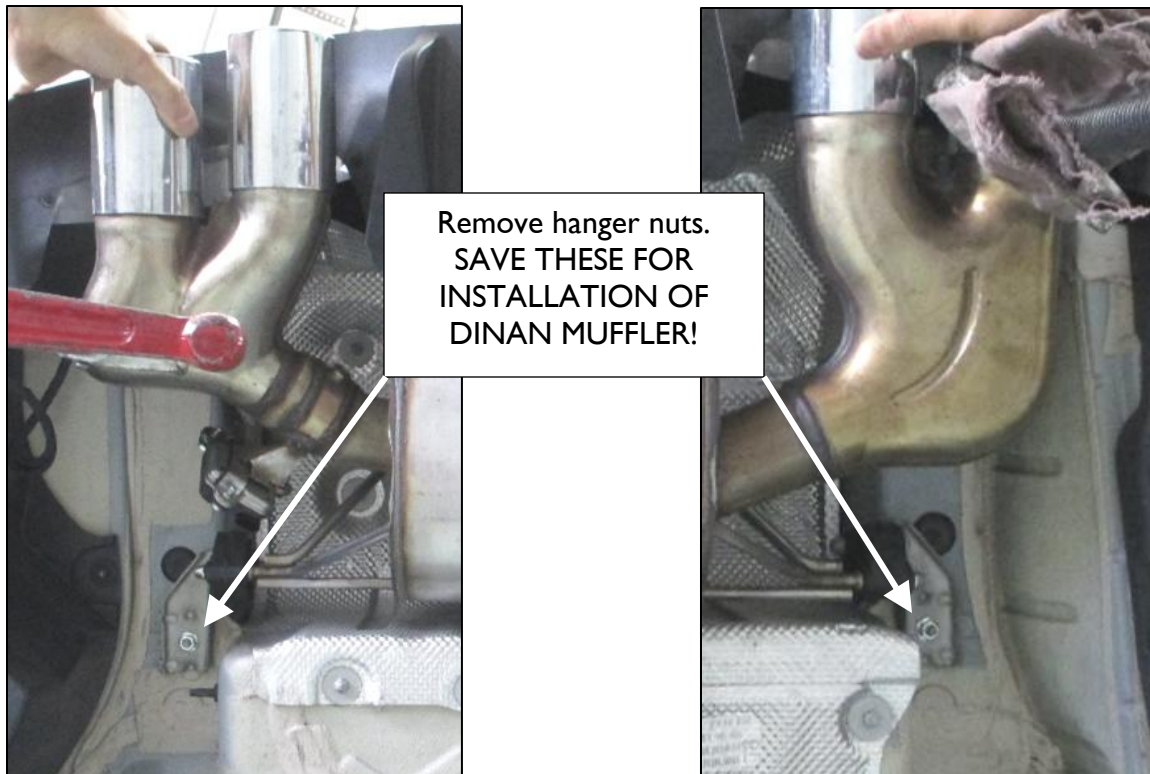

5. Remove both hangers and valve actuator from stock muffler. **SAVE THESE PARTS FOR INSTALLATION ON DINAN MUFFLER.**

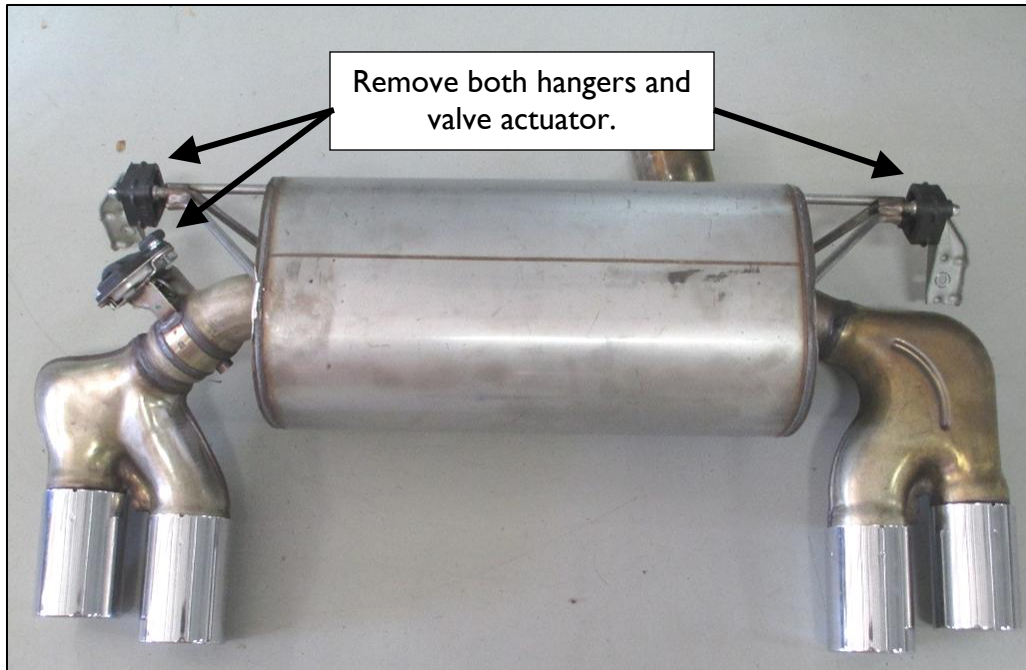

6. Install the valve actuator mounting brackets provided in the hardware kit as shown below. You will need (3) M6x20 bolts, (3) M6 locknuts, and (6) M6 washers from the hardware kit provided to install both mounting brackets. Notice the location of the spacer for mounting the actuator in the next step. Make sure all hardware is tight.

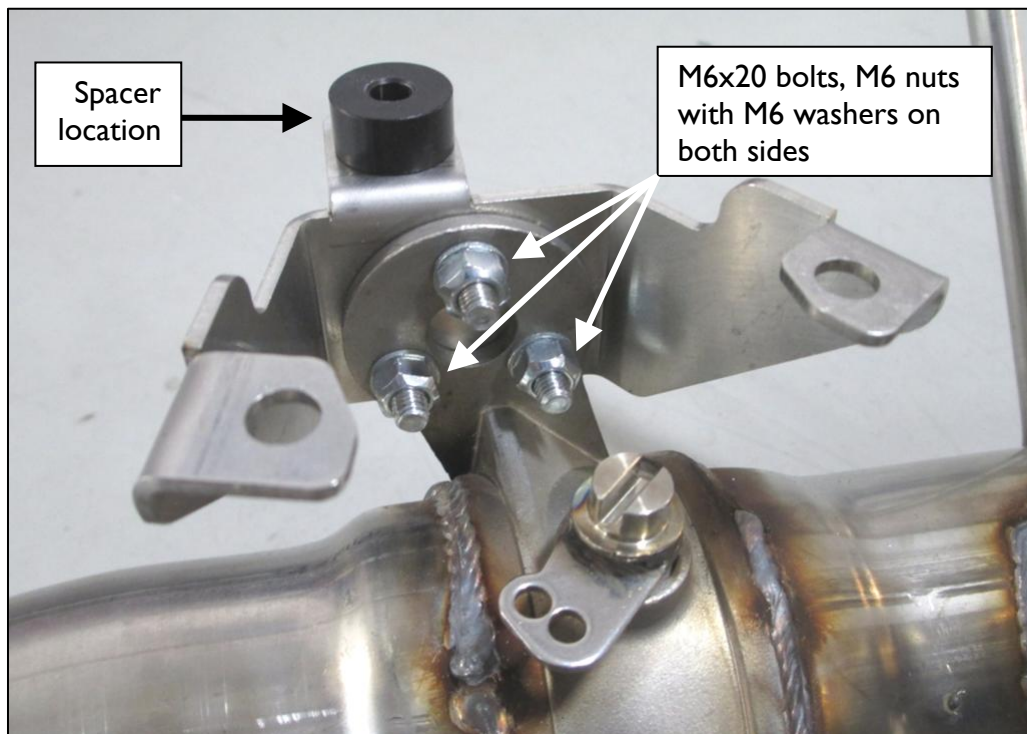

7. Install stock actuators onto DINAN muffler. You will need (2) M6x20 bolts, (1) M6x30 bolt, (3) M6 locknuts, (6) M6 washers, and (1) spacer from the hardware kit provided. Use picture below for correct orientation of spring. While holding the spring in the slot on the valve, place the actuator (with actuator plate) onto spring. Mount the actuator to the mounting bracket using the provided hardware. Before you fully tighten bolts make sure shafts are aligned (see photo). If the stock actuator shaft slot is in a different rotation than pictured below, simply turn the valve shaft slot on the muffler to line them up. Make sure all hardware is tight. **THE SPRING MUST BE SECURELY SEATED IN BOTH THE SLOT IN THE VALVE AND THE SLOT IN THE ACTUATOR!!!**

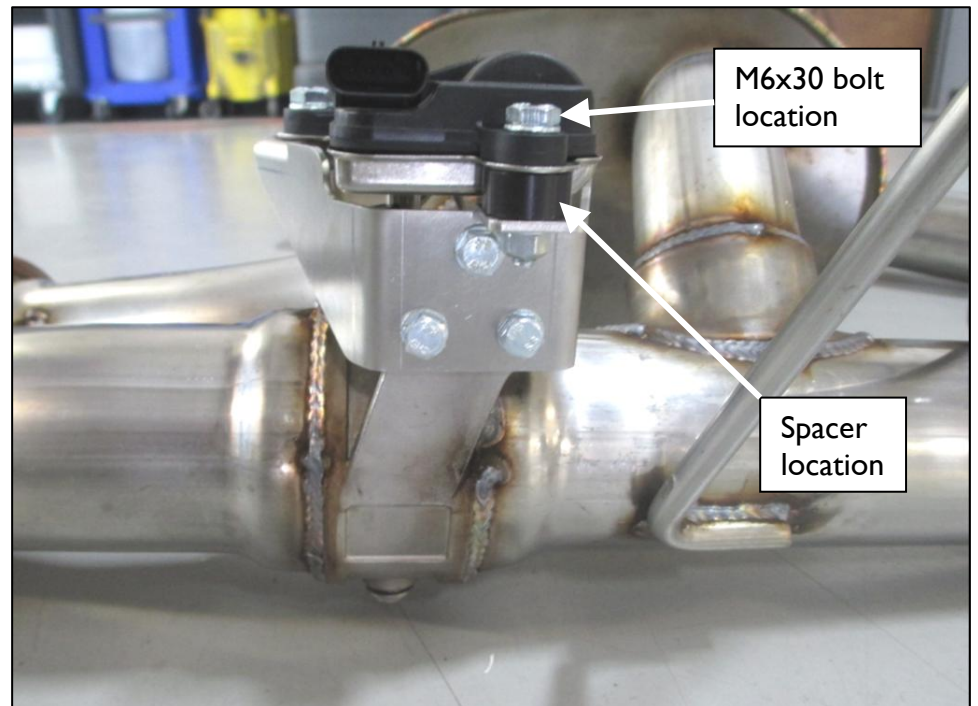
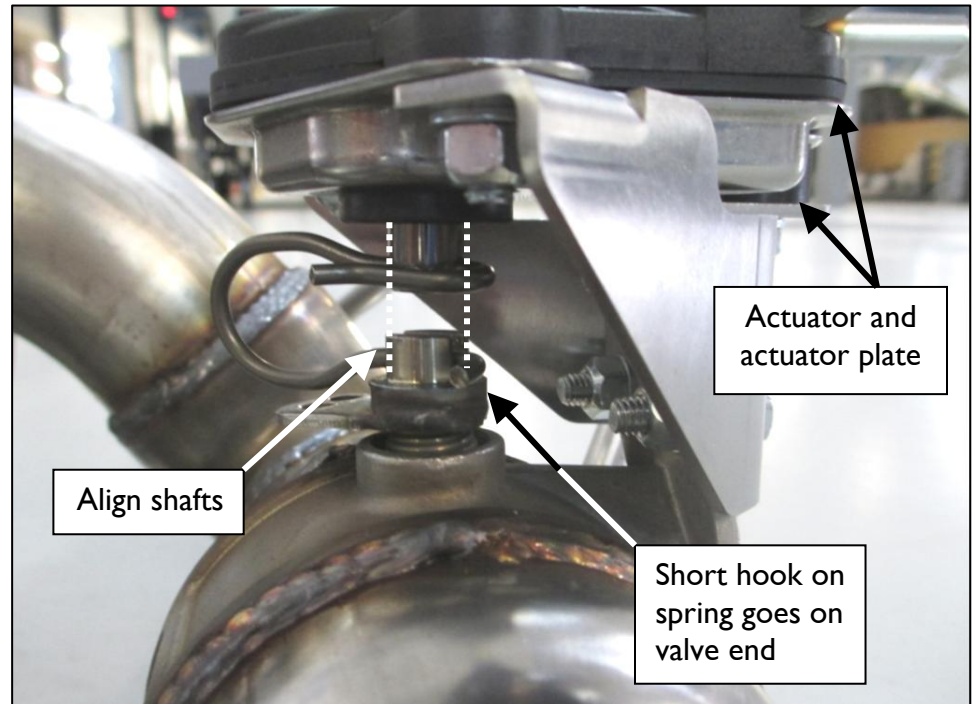
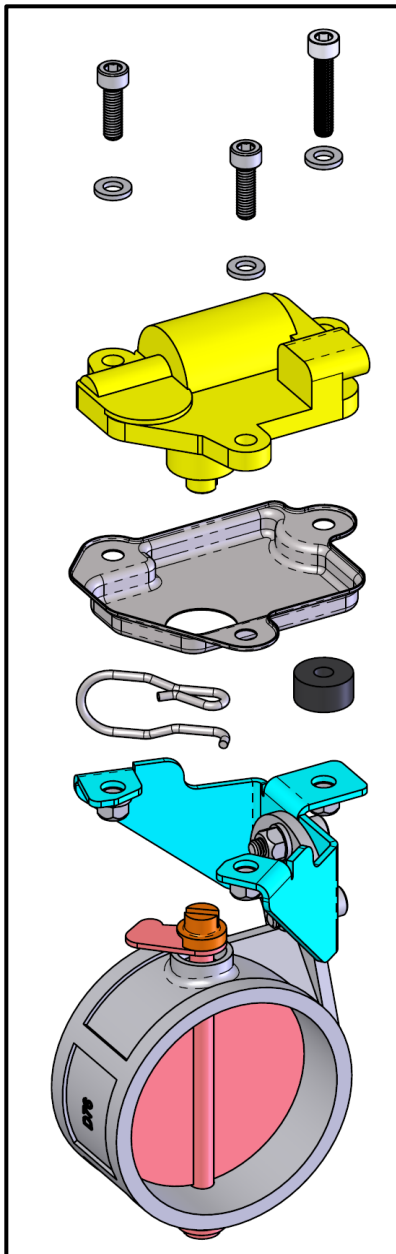

8. Install both stock hangers onto DINAN muffler as shown below.

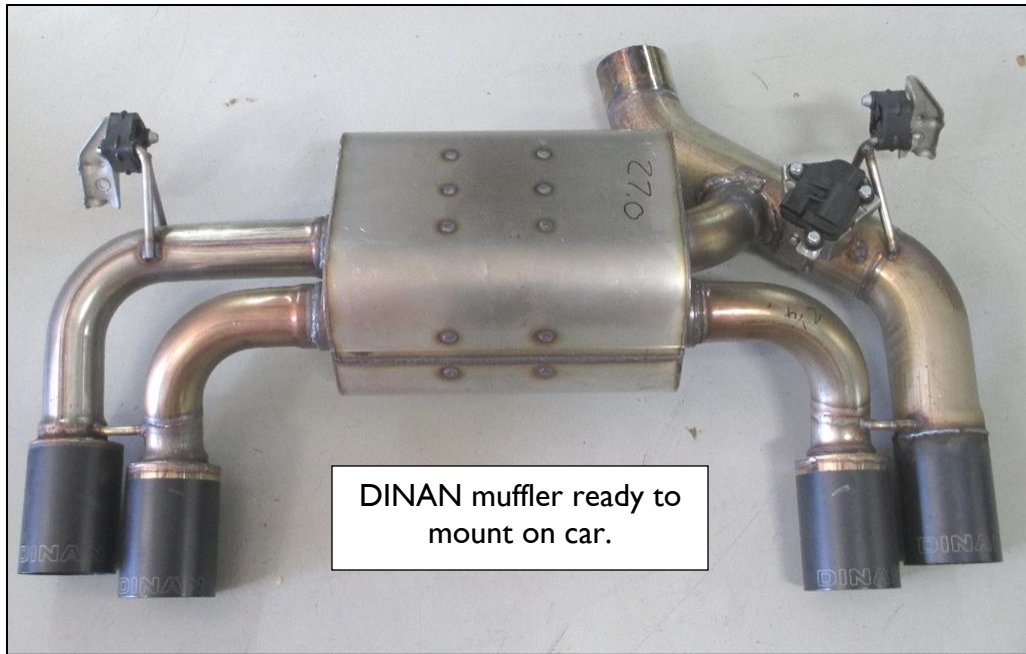

9. Remove the rear heat shield.

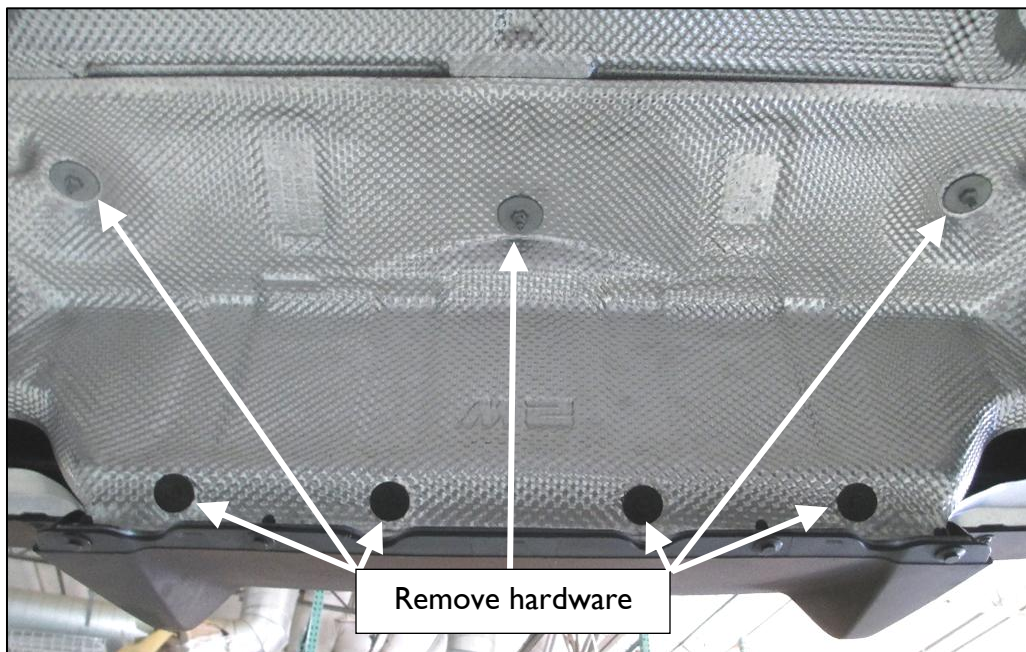

10. Install DINAN supplied valve harness using the zip ties found in the hardware kit as shown in **Figures 3, 4 and 5**. Then re-install rear heat shield.

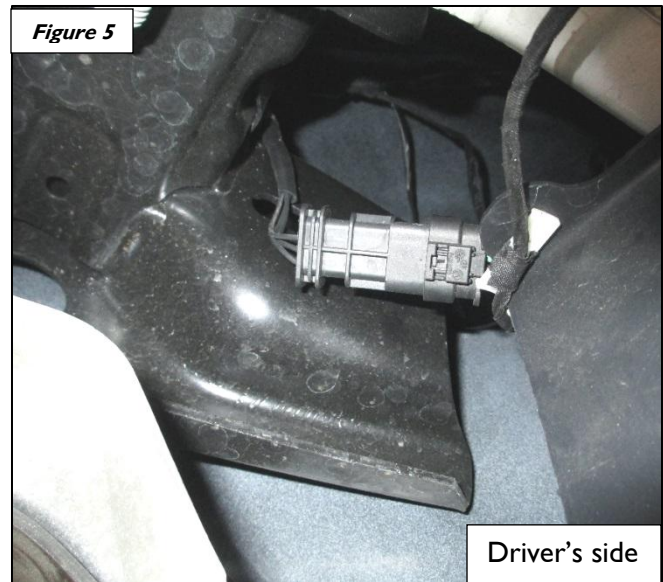
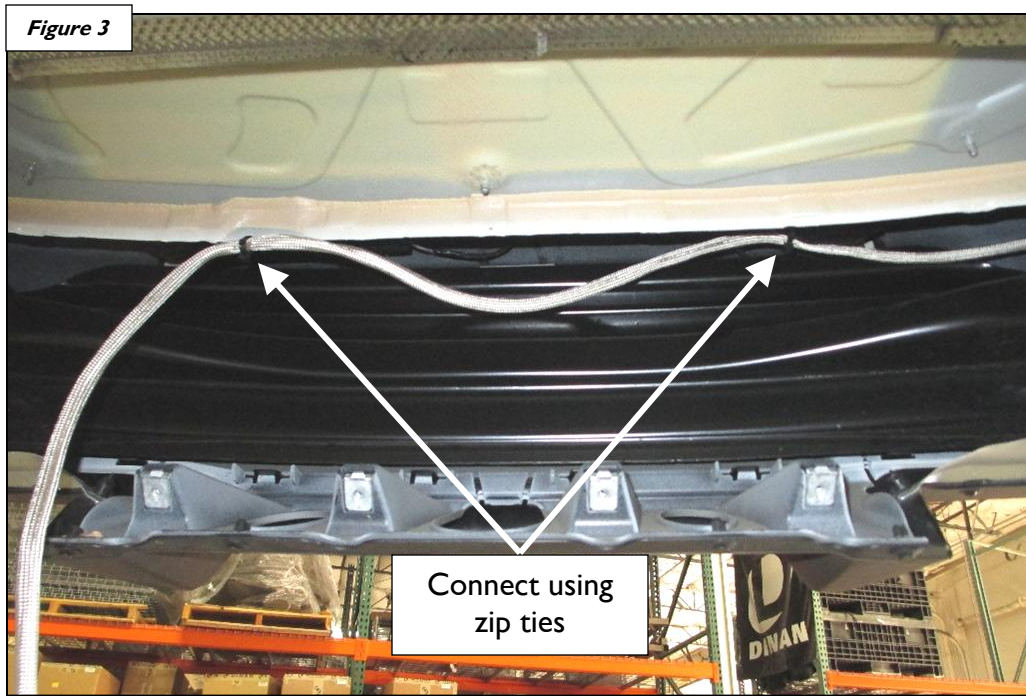

- Place exhaust clamp provided in the hardware kit onto the end of the stock exhaust pipe. With DINAN exhaust secured on a jack or stand, put the muffler in place. When mounting the muffler it should be held with the tips up near the bumper and the muffler pushed forward against the ends of the stock pipes.

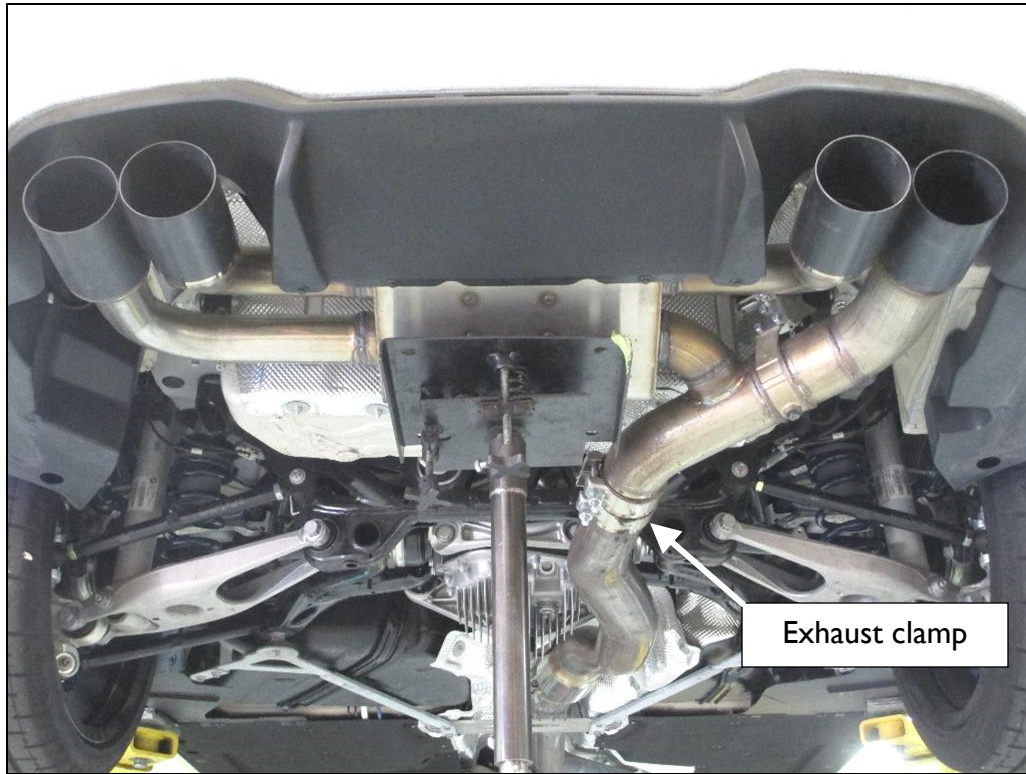

- Mount both muffler hangers using the stock mounting nuts that were saved from removal of the stock muffler. Torque the nuts to **14 ft-lbs (19 Nm)**.

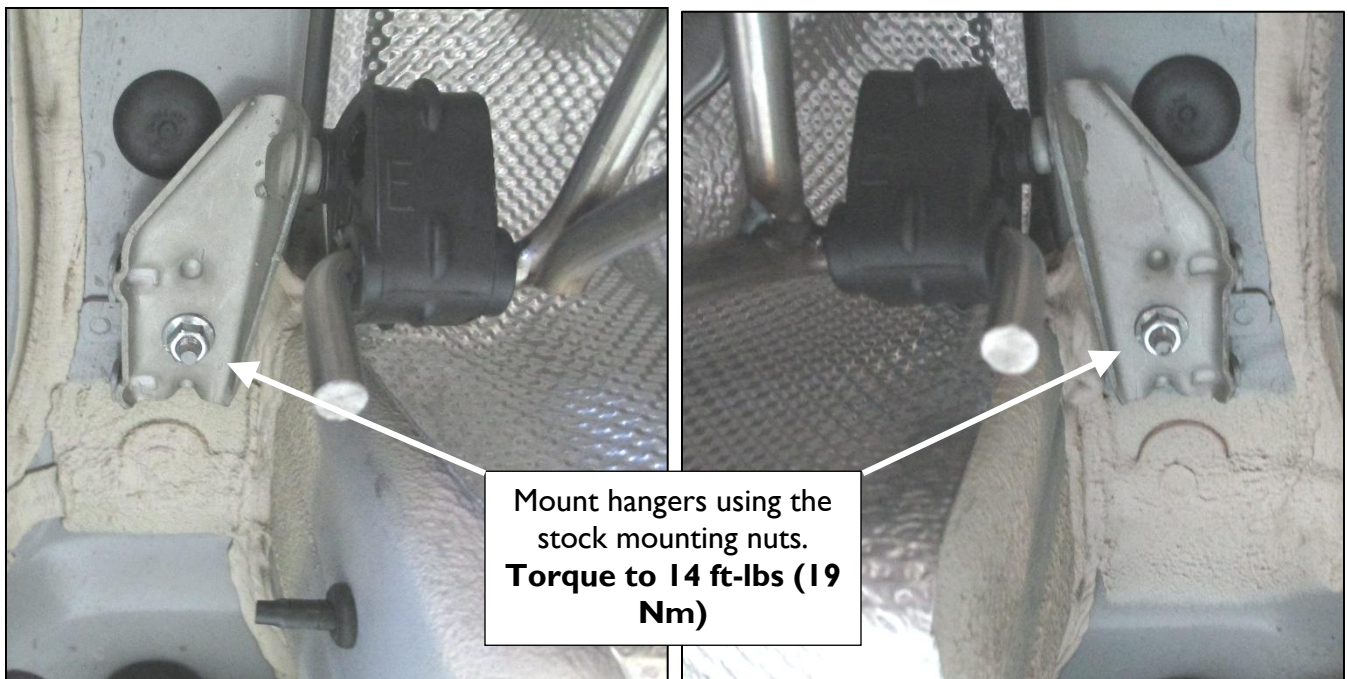

13. With exhaust clamp rotated as shown, torque clamps.
- Torque Clamps with 10mm bolts to 45Nm (33 ft-lbs)
 - Torque Clamps with 11mm bolts to 68Nm (50 ft-lbs)

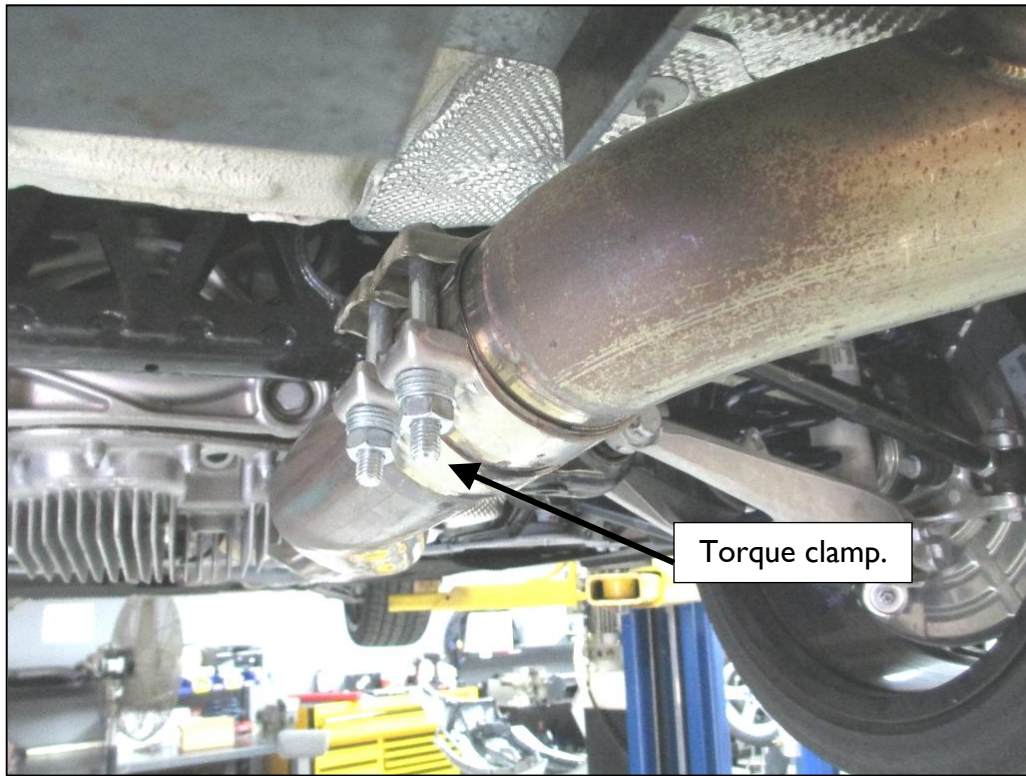

14. Connect valve actuator as shown below.



15. Check the exhaust tips for proper bumper clearance and proper alignment using **Figures 6 & 7.**

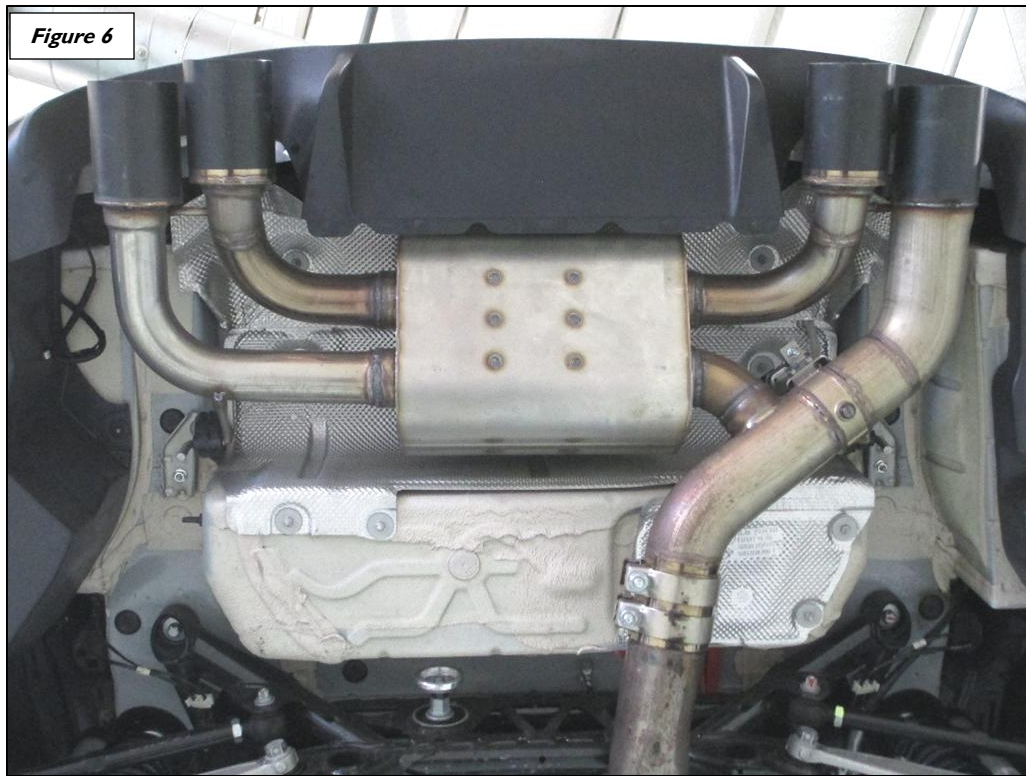

Enjoy your new DINAN exhaust!