



## **Free Flow Exhaust Installation Instructions**

PART NUMBER    D660-0040  
                         D660-0040-BLK

APPLICATION:    2011-15 650i & xDrive (F12 & F13)  
                         2015 Alpina B6 xDrive Gran Coupe (F06)

---

Thank you for purchasing a Dinan High Performance Muffler! Some mechanical skill is required to install this muffler. If you are not familiar with this procedure, we strongly recommend that you arrange for a qualified BMW repair facility to perform this installation.

### **INSTALLATION:**

- I. The Dinan mufflers are relatively easy to install. They fit the same as a stock replacement muffler would.

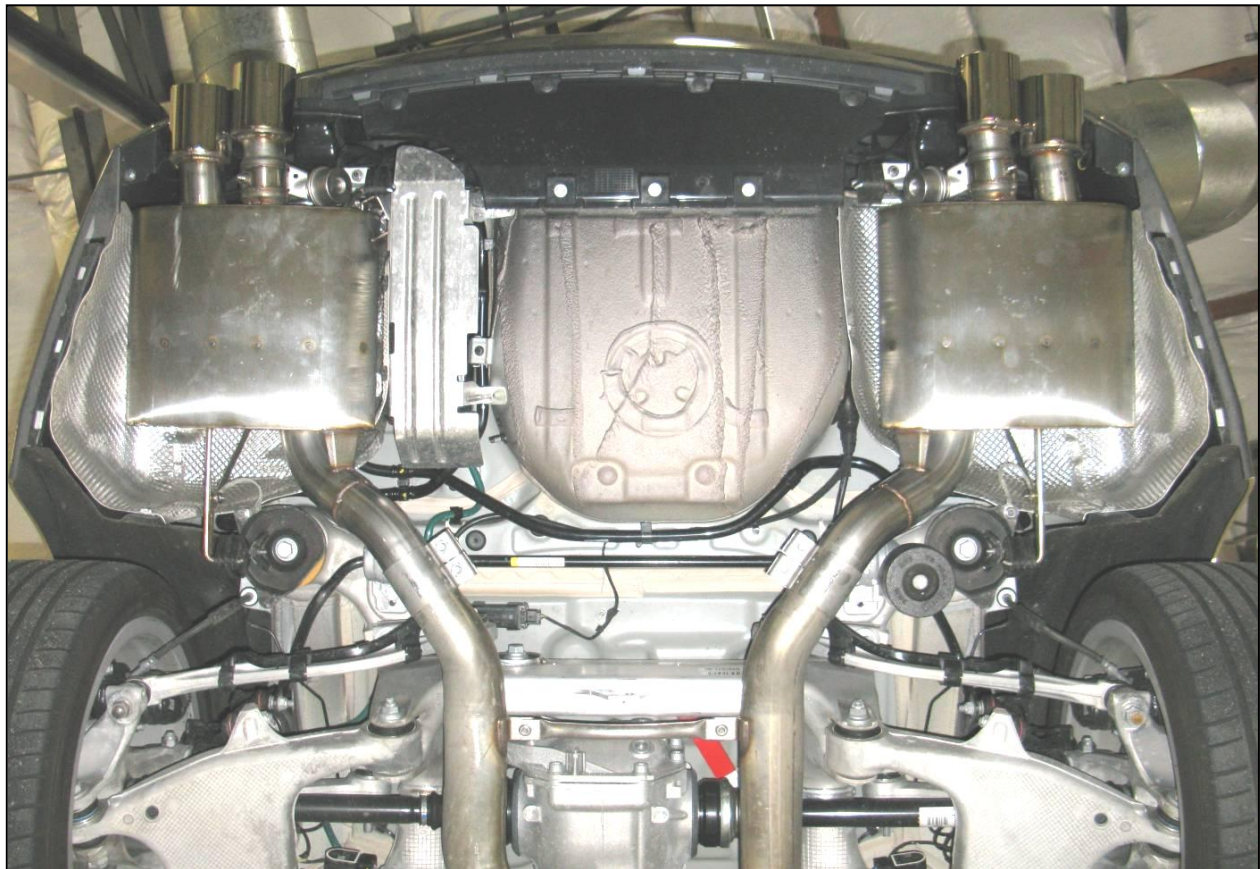

2. Start by removing the stone guard from the car as shown. Remove the three bolts holding the bumper to the car. Pull the bumper down slightly to give you access to the plastic nuts holding the stone guard to the car. Remove the nuts and screws and remove the stone guard. See figure 2.

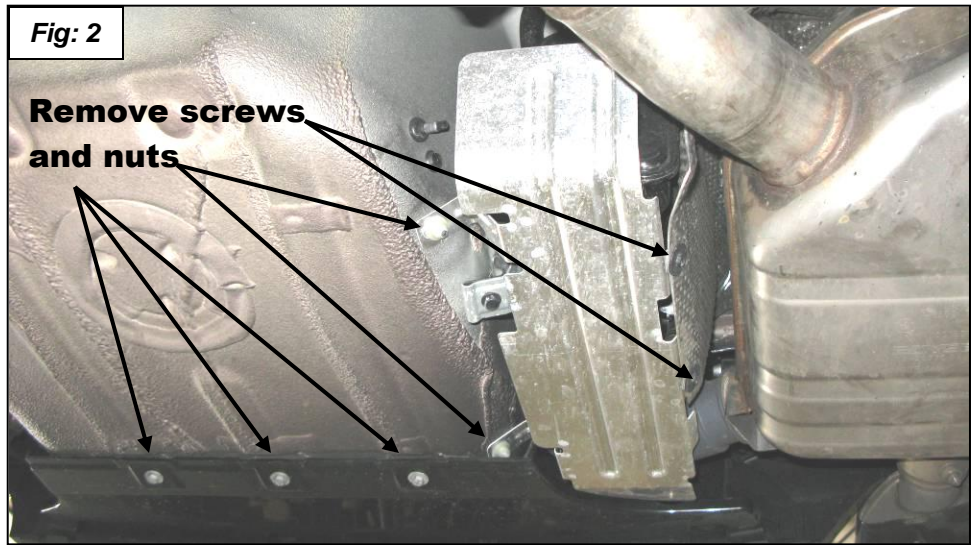

3. Cut off the stock mufflers at the punch marks as shown in figures 3 and 4. Mark the cut line. Use a Sawzall or similar cutting tool.

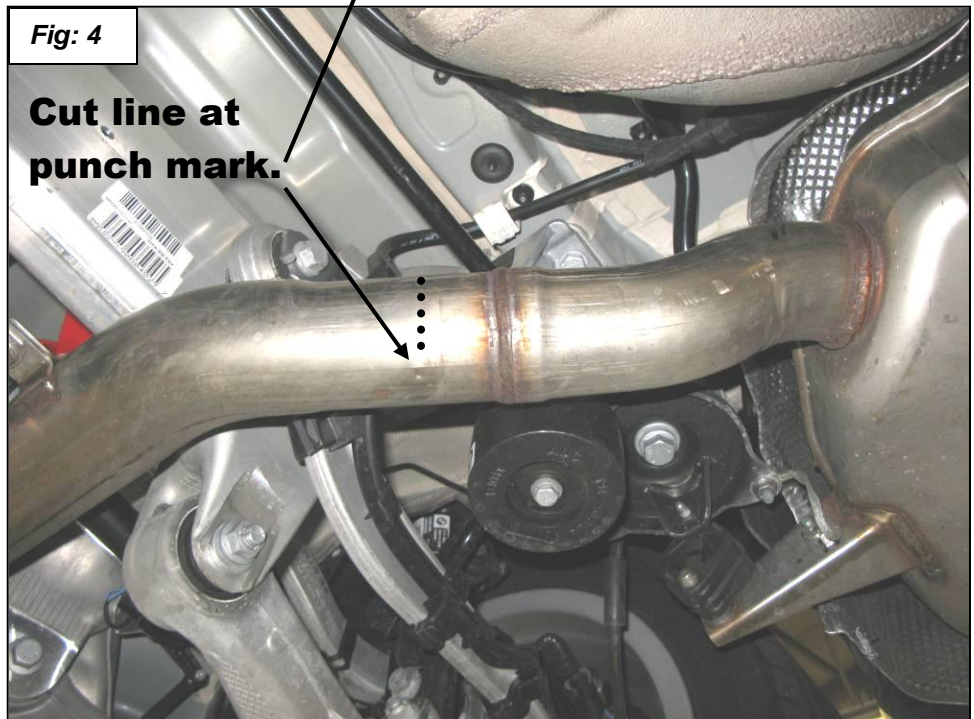
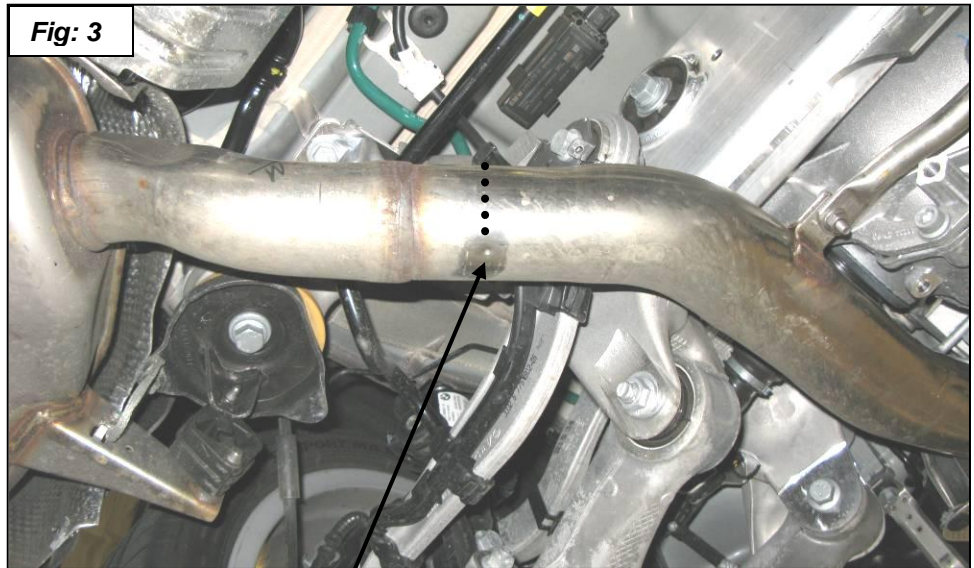



4. Support the stock muffler with a jack or stand.
5. Depending what car you have, remove nuts **(1)** or torx head bolt **(2)** as shown in figures 5, 6 and 7.
6. Remove nut **(3)** holding ground strap to muffler.

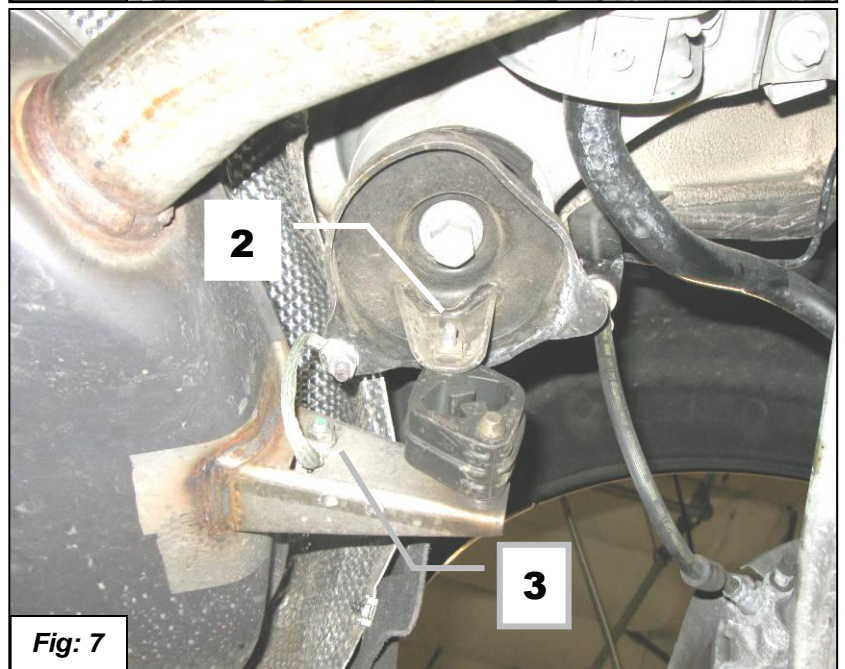
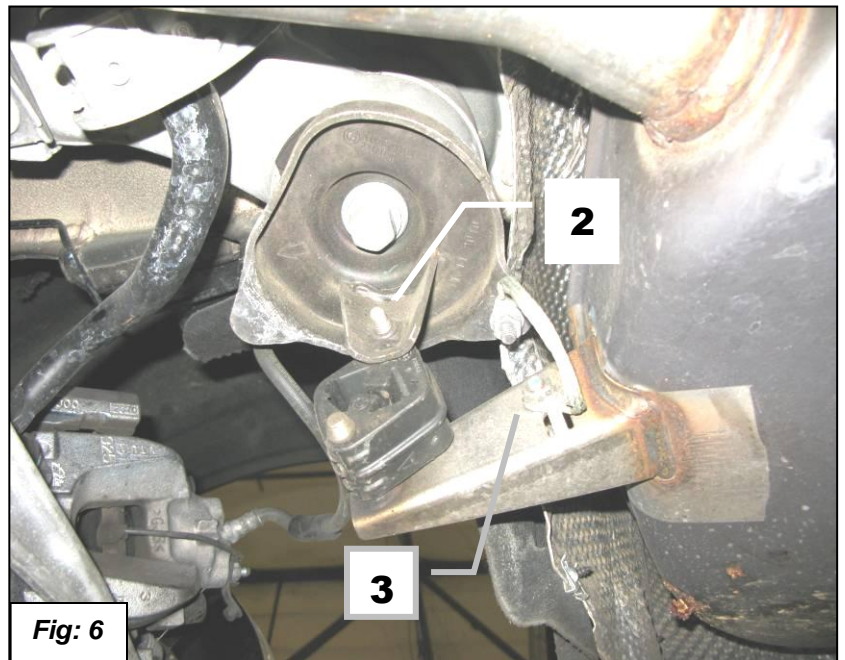
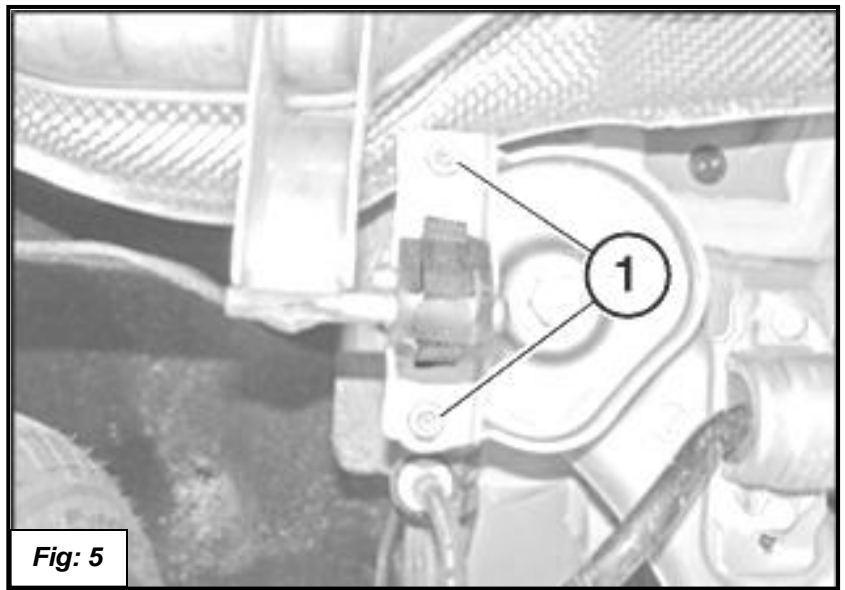

7. Remove nut **(1)** as shown.
8. Detach vacuum hose **(2)**.
9. Remove Vibration Absorber **(3)** from the driver's side muffler and transfer to the new muffler.
10. Transfer muffler hangers to new mufflers. Replace rubber hangers as needed.
11. Deburr the cut edges of the tubes on the car.
12. Slide clamping bushings over the tubes.

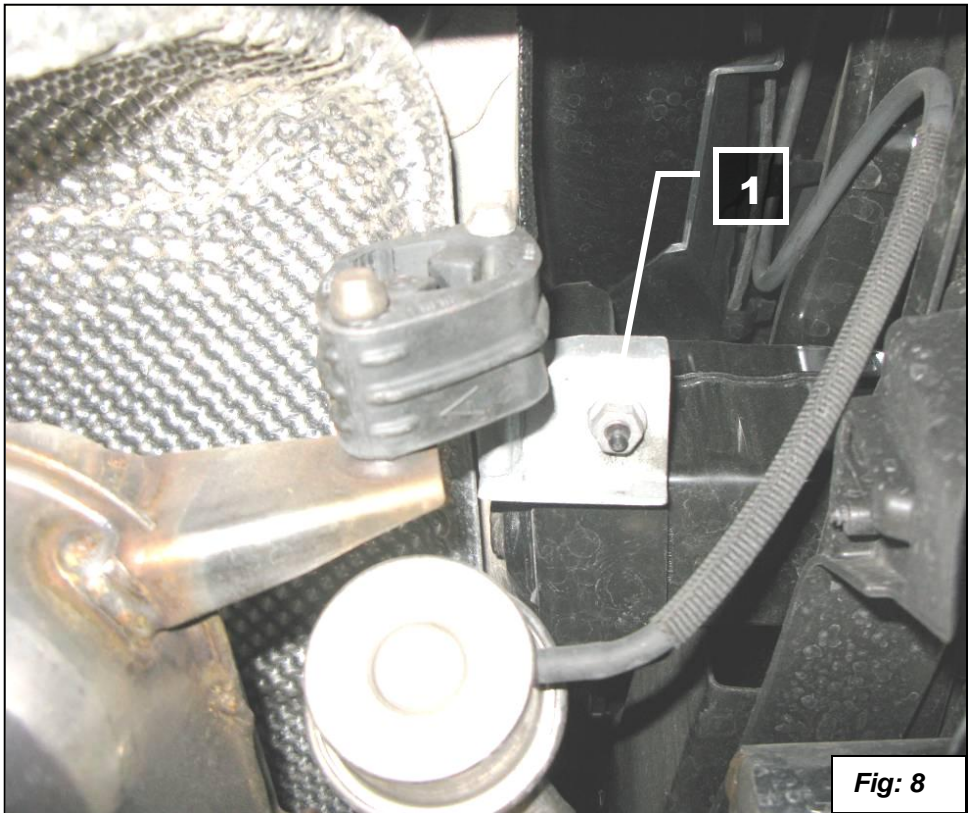

**Fig: 8**

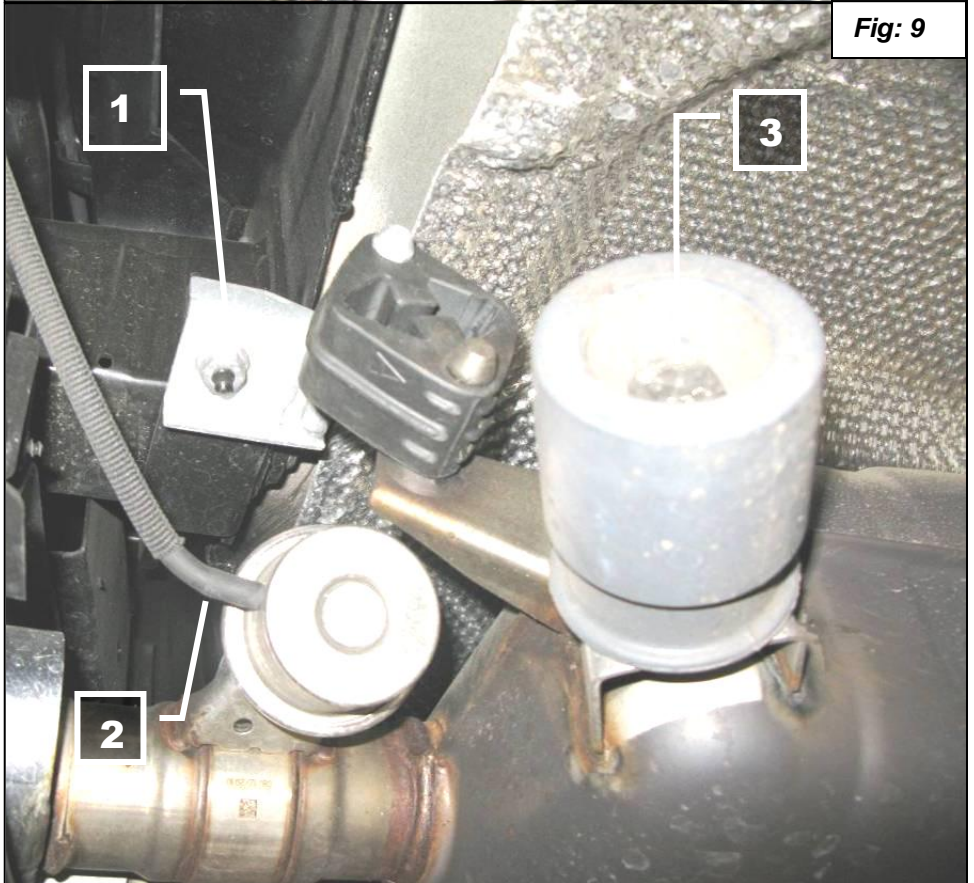

**Fig: 9**



13. You will need to trim the corners of the bumpers slightly for clearance when the exhaust grows when hot. See figures 10, 11, 12 and 13.

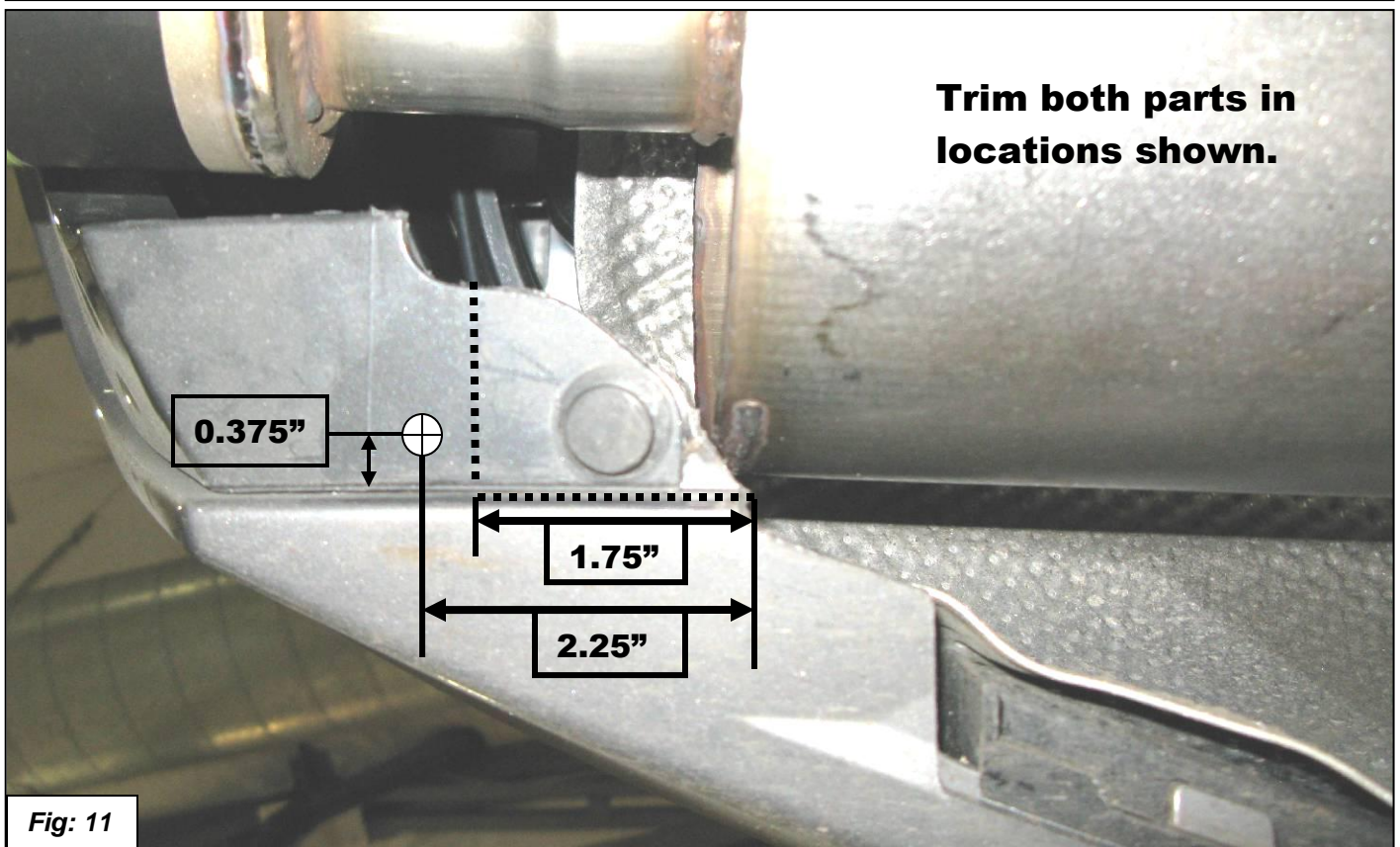
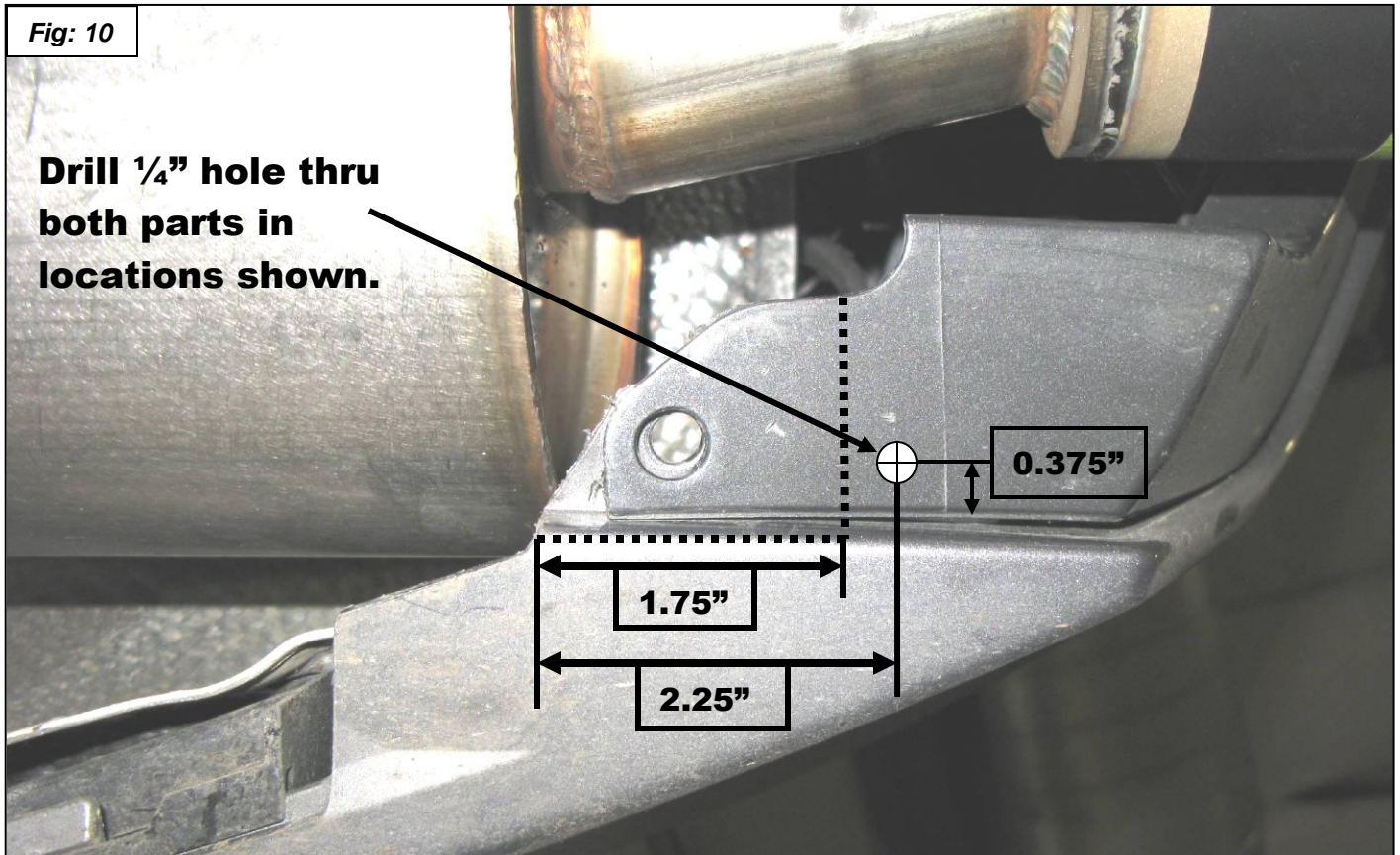

**Fig: 11**



You will need to add a bolt first then trim the plastic. Drill a ¼" hole in the location shown. Assemble the supplied bolts through the holes. Trim the bumper as shown. (Note the photos show the mufflers installed for reference.)

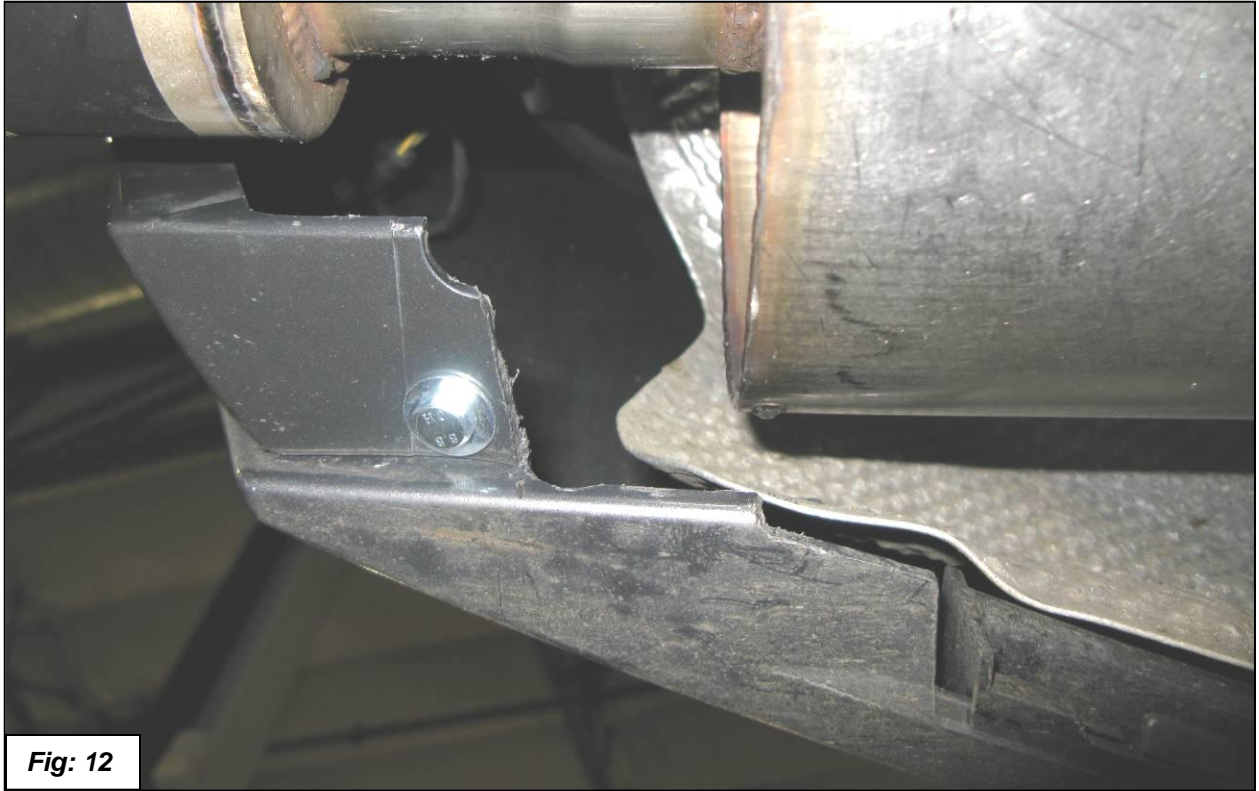

**Fig: 12**



**Fig: 13**



14. Install mufflers as shown. Torque the hanger bolts to 22NM. Center the mounting clamp and torque to 45NM. (Install tip) When installing mufflers it helps to have someone center and level the tips in the bumper opening while you tighten the clamps.

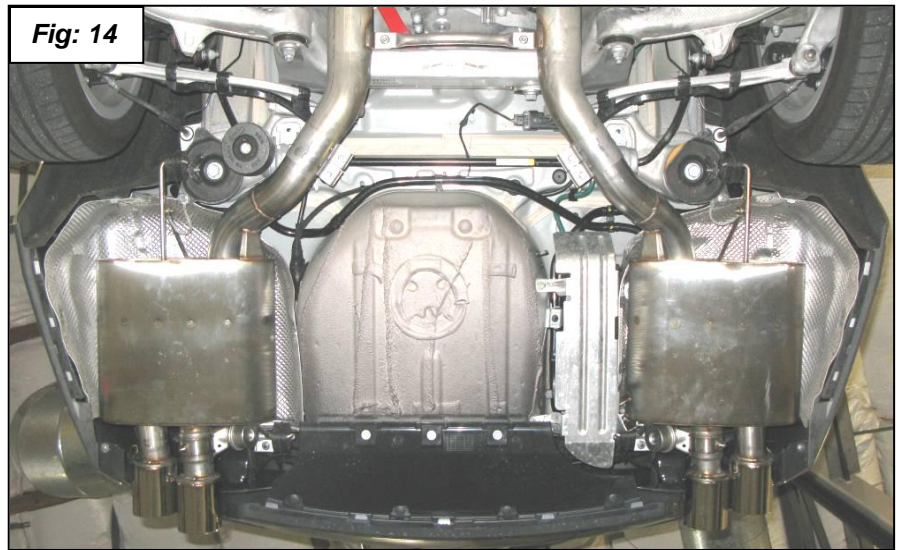

15. Connect the vacuum hose to the valves. Note: If your car had only 1 muffler with a valve attached to it you will need to add the supplied vacuum line over to the valve on the right side muffler. There is a vacuum "T" with a plug on it up above the left vacuum valve. Remove the plug and attach the new hose to it. Secure the hose in the stock holders.

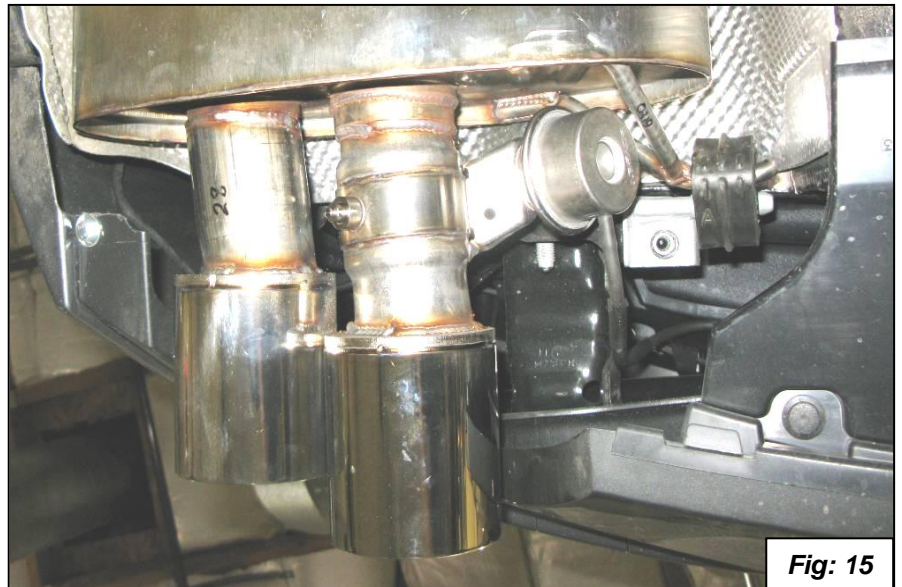

Fig: 15

16. Install the stone guard and bumper bolts.
17. Visually inspect the muffler. Check for at least 1/2" clearance in all areas. You can bend the heat shields slightly if needed.

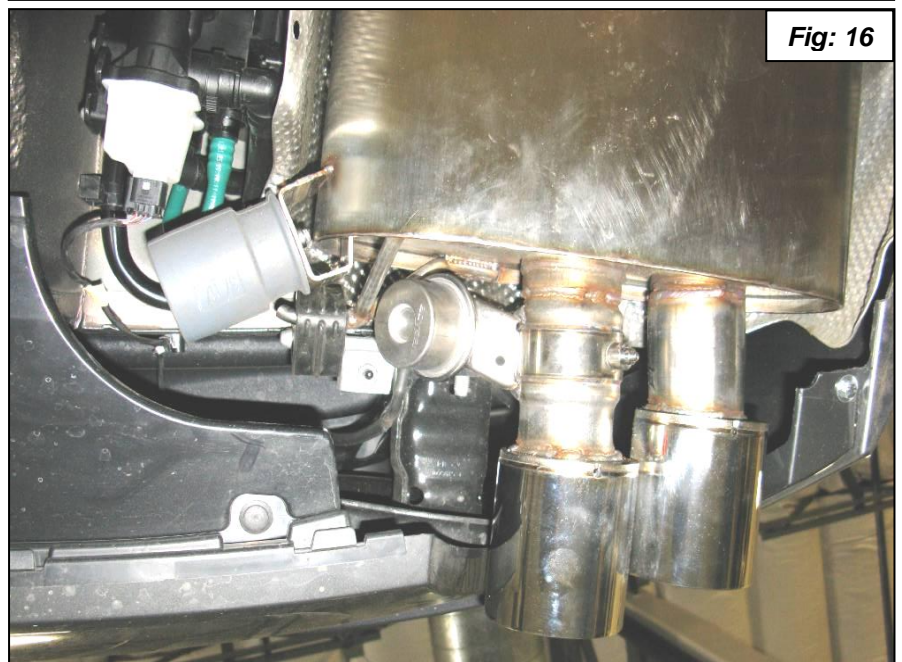

Fig: 16

Happy Motoring!