



LOWER CONTROL ARM MONOBALL KIT INSTALLATION INSTRUCTIONS

PART NUMBER D280-0009

APPLICATION: 2004-05 525i, 530i, 545i
2006-07 525i, 530i, 550i (not xi)
2008-10 528i, 535i, 550i (not xi)
2006-10 M5
2004-05 645ci (includes convertible)
2006-10 650i (includes convertible)
2006-10 M6 (includes convertible)

PARTS LIST

| Qty | Part # | Description |
|-----|-----------|-------------------------|
| 2 | D283-0013 | Monoball & Carrier Assy |
| 1 | D281-0003 | Loctite 609 Compound |
| 2 | D282-0027 | Retaining Caps |
| 10 | D671-0619 | M6x40 Stainless Screws |
| 4 | D282-0028 | Bearing Spacers |

Congratulations for being selective enough to use a Dinan Engineering Monoball Kit. We have spent many hours developing this kit to assure that you will receive maximum performance and durability with minimum difficulty in installation. Please take the time to read these instructions and call us if you have any difficulties during the installation.

DO NOT WORK ON VEHICLES SUPPORTED BY A JACK ONLY. USE SECURE JACK STANDS!

INSTALLATION:

1. Remove the front Tension-Compression Arms, and press out the stock rubber bushing per BMW recommended procedure.
2. Clean out the bore with some soap and scotch-brite. The bore needs to be very clean and dry.
3. Apply some Loctite 609 Retaining Compound (included in kit) to the outer bore of the Dinan monoball carrier. Use enough to cover most of the surface.

4. See figure below. Slide the carrier into the bore in the arm with a slight turning motion to further spread the Loctite around. It does not matter from which side of the arm you install the carrier, but it is preferred if both sides of the car were the same.

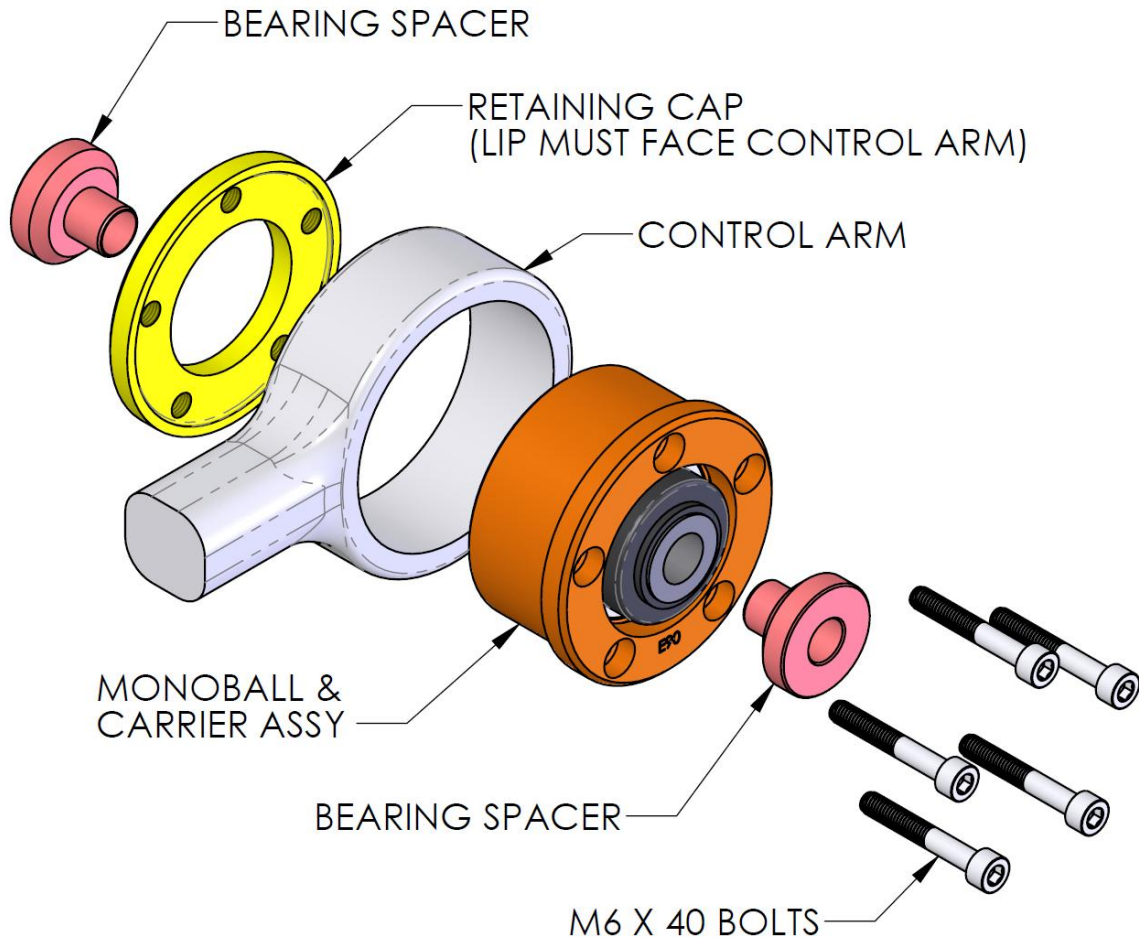

5. Install the Dinan retaining cap onto the arm (the lip must face the control arm as shown). Put a small amount of Loctite on the M6x40 bolts and torque to 95 inch-pounds to secure the retaining cap.
6. Install the Dinan silver bearing spacers as shown.
7. Install the arms to the car using the stock bolts & nuts (replace as necessary).
8. Torque the bolts per BMW recommended procedure. NOTE: The monoball bolts must also be angle torqued per BMW specification!
9. Enjoy!