



DINAN

**ADJUSTABLE ANTI-ROLL BAR
INSTALLATION INSTRUCTIONS**

PART NUMBER D120-0520

DESCRIPTION: Front 32mm; 3-hole adjustable

APPLICATION: 2008-13 M3 (E90, E92, & E93)

2011 I-M Coupe (E82)

PARTS LIST

Qty	Part #	Description
1	D122-0520	Anti-roll bar
1	D133-0520	Hardware kit

Congratulations for being selective enough to use a Dinan Engineering anti-roll bar. We have spent many hours developing this anti-roll bar to assure that you will receive maximum performance and durability with minimum difficulty in installation. Please take the time to read these instructions and call us if you have any difficulties during the installation.

NOTES:

- a) We highly recommend that you first read and fully understand these instructions before beginning the installation.
 - b) Some mechanical skill is required to install this kit. If you feel that you do not have the requisite skill or tools, please arrange for a qualified repair facility to perform the installation.
 - c) Do not work on vehicles supported by a jack only. Use secure jack stands!
-

1. Jack up the front of the vehicle and place jack stands securely under the vehicle.
2. Note the orientation of the stock anti-roll bar. The Dinan bar will be oriented the same way.
3. Remove the stock anti-roll bar, bushings, brackets, and end links per BMW recommended procedure. These items will not be reused.
4. Install Dinan anti-roll bar using the supplied bushings and brackets. Lubricate the bushings with urethane grease (or an equivalent high-pressure, waterproof, grease).
5. For easy adjustment, the Dinan end links are left/right hand threaded. These links must be adjusted to the correct length for the hole that you will be using. Failure to follow the subsequent steps can result in loss of control, vehicle damage, and injury!
6. Attach Dinan end links to the strut using the coned washers and 10mm nylon locknuts as shown.

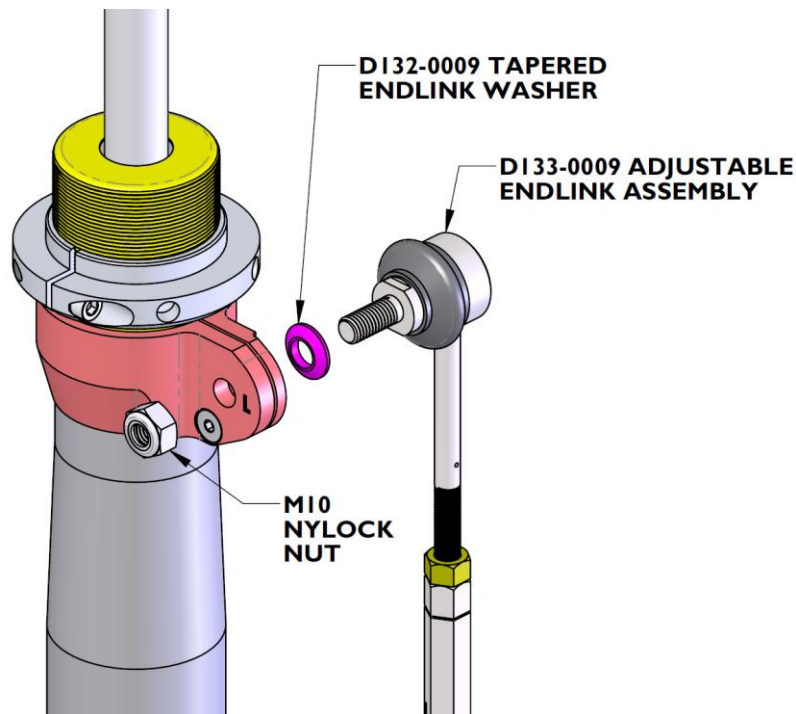

7. See figure below for description of adjustments, and determine which holes you will be using. It is OK to attach to different holes each arm, to “split” the adjustment. Dinan recommends starting at the middle hole on both sides, and then adjusting as needed after evaluating the handling.

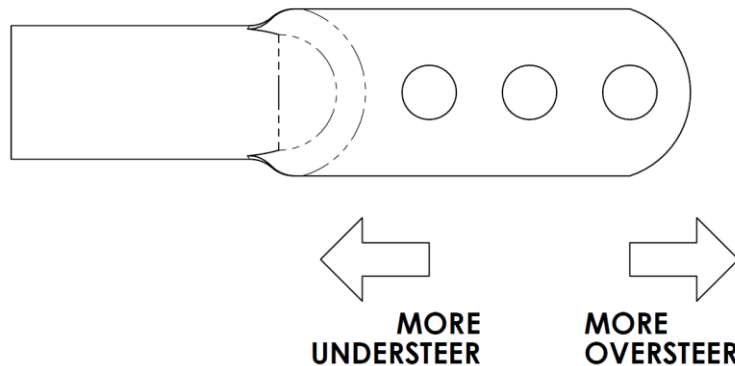

8. The end links must be adjusted to the correct length for the setting you've chosen. This is critical for proper function and safety. Incorrectly adjusted end links could result in loss of control, vehicle damage, and injury! Please review the following steps carefully, and contact Dinan technical support if there are any questions.
9. With the car in the air and the suspension in full droop, turn steering to full lock and hold it in that position.
10. Swing anti-roll bar downwards until one arm just contacts the pleats of the extended steering rack boot.
11. Turn steering to full lock in the opposite direction and check clearance between the other arm and steering rack boot. **The goal is to have the bar as low as possible, and just touching the steering rack boots when the suspension is at full droop, and at full steering lock.**
12. While carefully holding the anti-roll bar in this position, turn the steering straight ahead.

13. Loosen the jam nuts on the end link and turn the center section to lengthen/shorten the link. Adjust length as needed and attach the links to the anti-roll bar at the holes you've chosen, using the 10mm flanged locknuts as shown. Please note that the ball joint is on the inside of the bar and the stud points out (this is opposite of stock).

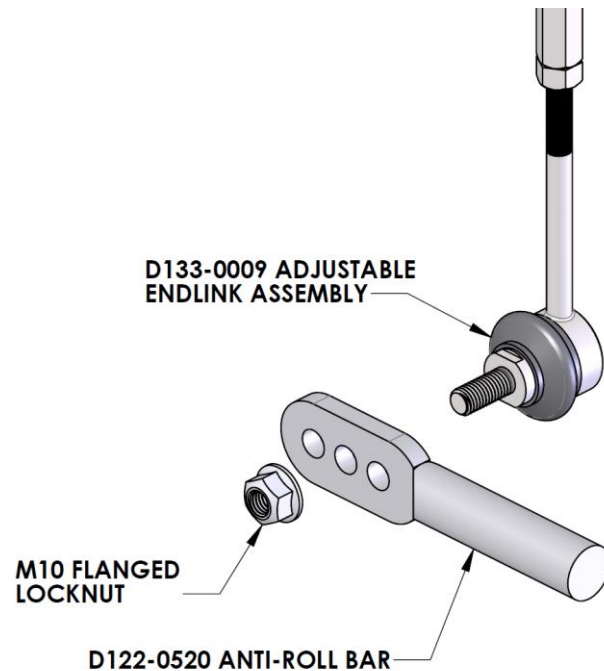

14. Rotate the ball joints so that the studs are centered (to allow for maximum movement without binding), and tightening the jam nuts. This must be done while the steering is pointed straight ahead, to prevent binding during steering!
15. Check your work! Turn steering lock to lock in both directions to double check the bar position. Light contact with the steering rack boots with the suspension at full droop is the goal. Also verify there is no binding in the end links. Please contact Dinan technical support if there are any questions!
16. These checks must be performed each time the anti-roll bar is adjusted.
17. Reassemble the car per BMW recommended procedure.
18. Remove "preload" from the anti-roll bar as follows:
- Set car on the ground (or alignment rack) with the steering pointed straight ahead.
 - Disconnect one end link from the anti-roll bar.
 - Loosen jam nuts and adjust the end link length as required to align the stud with your chosen hole.
 - Reattach end link to the anti-roll bar and tighten the jam nuts.

We hope you enjoy your new Dinan Engineering anti-roll bar!