



| Volts         | Minimum Gauge for Cord Sets  |        |         |                 |
|---------------|------------------------------|--------|---------|-----------------|
|               | Total Length of Cord in Feet |        |         |                 |
| 120V          | 0-25                         | 26-50  | 51-100  | 101-150         |
| 240V          | 0-50                         | 51-100 | 101-200 | 201-300         |
| Ampere Rating |                              | AWG    |         |                 |
| More Than     | Not more Than                |        |         |                 |
| 0             | - 6                          | 18     | 16      | 16              |
| 6             | - 10                         | 18     | 16      | 14              |
| 10            | - 12                         | 16     | 16      | 14              |
| 12            | - 16                         | 14     | 12      | Not Recommended |

3) PERSONAL SAFETY

- a) **Stay alert, watch what you are doing and use common sense when operating a power tool. Do not use a power tool while you are tired or under the influence of drugs, alcohol or medication.** A moment of inattention while operating power tools may result in serious personal injury.
- b) **Use safety equipment. Always wear eye protection.** Safety equipment such as dust mask, non-skid safety shoes, hard hat, or hearing protection used for appropriate conditions will reduce personal injuries.
- c) **Avoid accidental starting. Ensure the switch is in the off-position before plugging in.** Carrying power tools with your finger on the switch or plugging in power tools that have the switch on invites accidents.
- d) **Remove any adjusting key or wrench before turning the power tool on.** A wrench or a key left attached to a rotating part of the power tool may result in personal injury.
- e) **Do not overreach. Keep proper footing and balance at all times.** This enables better control of the power tool in unexpected situations.
- f) **Dress properly. Do not wear loose clothing or jewellery. Keep your hair, clothing and gloves away from moving parts.** Loose clothes, jewellery or long hair can be caught in moving parts. Air vents often cover moving parts and should also be avoided.
- g) **If devices are provided for the connection of dust extraction and collection facilities, ensure these are connected and properly used.** Use of these devices can reduce dust-related hazards.

4) POWER TOOL USE AND CARE

- a) **Do not force the power tool. Use the correct power tool for your application.** The correct power tool will do the job better and safer at the rate for which it was designed.
- b) **Do not use the power tool if the switch does not turn it on and off.** Any power tool that cannot be controlled with the switch is dangerous and must be repaired.
- c) **Disconnect the plug from the power source and/or the battery pack from the power tool before making any adjustments, changing accessories, or storing power tools.** Such preventive safety measures reduce the risk of starting the power tool accidentally.
- d) **Store idle power tools out of the reach of children and do not allow persons unfamiliar with the power tool or these instructions to operate the power tool.** Power tools are dangerous in the hands of untrained users.
- e) **Maintain power tools. Check for misalignment or binding of moving parts, breakage of parts and any other condition that may affect the power tools operation. If damaged, have the power tool repaired before use.** Many accidents are caused by poorly maintained power tools.
- f) **Keep cutting tools sharp and clean.** Properly maintained cutting tools with sharp cutting edges are less likely to bind and are easier to control.
- g) **Use the power tool, accessories and tool bits etc., in accordance with these instructions and in the manner intended for the particular type of power tool, taking into account the working conditions and the work to be performed.** Use of the power tool for operations different from those intended could result in a hazardous situation.

5) SERVICE

- a) **Have your power tool serviced by a qualified repair person using only identical replacement parts.** This will ensure that the safety of the power tool is maintained.

**Additional Safety Rules Instructions for Shears**

- **Hold tool by insulated gripping surfaces when performing an operation where the cutting tools may contact hidden wiring or its own cord.** Contact with a "live" wire will make exposed metal parts of the tool "live" and shock the operator.
- **Cut material at or below rated capacity. Remember, material thickness increases as gauge number decreases (14 gauge is thicker than 16 gauge). 14 gauge thickness is .075" (1.9 mm); 16 gauge is .060" (1.5 mm).**
- **NEVER have any part of your body near the blades.** Serious personal injury may result.
- **Keep hands away from cutting area.** A moment of inattention while operating power tools may result in serious personal injury.
- **ALWAYS wear gloves when handling sheet metal.** The edges are sharp and can cause serious personal injury.
- **Firmly secure the piece of metal to be cut** to prevent movement during cutting.
- **ALWAYS start tool before engaging material** to be cut.
- **ALWAYS use tool with curl deflector.**
- **If possible, cut material so scrap curl is to the right.** This direction will move curl down and out of the way.
- **Use shears upright.** If tool is upside down, metal curl may turn toward you.
- **DO NOT use the shear with any kind of accessory or attachment.**
- **Always wear safety shoes** to protect your feet from sharp metal debris on the floor.
- **Keep all screws tight.** Check periodically for loosening.
- **Do not place anything into the motor housing openings.**
- **Clean out your tool often, especially after heavy use.** Dust and grit containing metal particles often accumulate on interior surfaces and could create an electric shock hazard.
- **Stay clear of end pieces that may fall after being cut off.** Contact with a sharp edge could result in personal injury.
- **Always keep the power cord away from the edge of the material being cut.** Sharp edges can result in the cord insulation being cut. This condition may create an electrical hazard.

**▲WARNING: ALWAYS use safety glasses.** Everyday eyeglasses are NOT safety glasses. Also use face or dust mask if cutting operation is dusty. ALWAYS WEAR CERTIFIED SAFETY EQUIPMENT:

- ANSI Z87.1 eye protection (CAN/CSA Z94.3)
- ANSI S12.6 (S3.19) hearing protection
- NIOSH/OSHA/MSHA respiratory protection.

**▲WARNING: Always use eye protection.** All users and bystanders must wear eye protection that conforms to ANSI Z87.1.

**▲WARNING: Some dust created by power sanding, sawing, grinding, drilling, and other construction activities contains chemicals known to cause cancer, birth defects or other reproductive harm.** Some examples of these chemicals are:

- lead from lead-based paints,
- crystalline silica from bricks and cement and other masonry products, and
- arsenic and chromium from chemically-treated lumber (CCA).

Your risk from these exposures varies, depending on how often you do this type of work. To reduce your exposure to these chemicals: work in a well ventilated area, and work with approved safety equipment, such as those dust masks that are specially designed to filter out microscopic particles.

• **Avoid prolonged contact with dust from power sanding, sawing, grinding, drilling, and other construction activities. Wear protective clothing and wash exposed areas with soap and water.** Allowing dust to get into your mouth, eyes, or lay on the skin may promote absorption of harmful chemicals.

**▲WARNING: Use of this tool can generate and/or disburse dust, which may cause serious and permanent respiratory or other injury.** Always use NIOSH/OSHA approved respiratory protection appropriate for the dust exposure. Direct particles away from face and body.

• The label on your tool may include the following symbols. The symbols and their definitions are as follows:

|                   |                             |
|-------------------|-----------------------------|
| V..... volts      | A ..... amperes             |
| Hz..... hertz     | W ..... watts               |
| min ..... minutes | ~ ..... alternating current |

The following are trademarks for one or more DEWALT power tools: the yellow and black color scheme; the "D" shaped air intake grill; the array of pyramids on the handgrip; the kit box configuration; and the array of lozenge-shaped humps on the surface of the tool.

**Definitions: Safety Guidelines**

The definitions below describe the level of severity for each signal word. Please read the manual and pay attention to these symbols.

**▲DANGER:** Indicates an imminently hazardous situation which, if not avoided, will result in death or serious injury.

**▲WARNING:** Indicates a potentially hazardous situation which, if not avoided, could result in death or serious injury.

**▲CAUTION:** Indicates a potentially hazardous situation which, if not avoided, may result in minor or moderate injury.

**CAUTION:** Used without the safety alert symbol indicates a potentially hazardous situation which, if not avoided, may result in property damage.

**General Safety Rules – For All Tools**

**WARNING!** Read all instructions. Failure to follow all instructions listed below may result in electric shock, fire and/or serious injury. The term "power tool" in all of the warnings listed below refers to your mains-operated (corded) power tool or battery-operated (cordless) power tool.

**SAVE THESE INSTRUCTIONS**

1) WORK AREA SAFETY

- a) **Keep work area clean and well lit.** Cluttered or dark areas invite accidents.
- b) **Do not operate power tools in explosive atmospheres, such as in the presence of flammable liquids, gases or dust.** Power tools create sparks which may ignite the dust or fumes.
- c) **Keep children and bystanders away while operating a power tool.** Distractions can cause you to lose control.

2) ELECTRICAL SAFETY

- a) **Power tool plugs must match the outlet. Never modify the plug in any way. Do not use any adapter plugs with earthed (grounded) power tools.** Unmodified plugs and matching outlets will reduce risk of electric shock
- b) **Avoid body contact with earthed or grounded surfaces such as pipes, radiators, ranges and refrigerators.** There is an increased risk of electric shock if your body is earthed or grounded.
- c) **Do not expose power tools to rain or wet conditions.** Water entering a power tool will increase the risk of electric shock
- d) **Do not abuse the cord. Never use the cord for carrying, pulling or unplugging the power tool. Keep cord away from heat, oil, sharp edges or moving parts.** Damaged or entangled cords increase the risk of electric shock. Replace or repair damaged cords. Make sure your extension cord is in good condition. Use only 3-wire extension cords that have 3-prong grounding-type plugs and 3-pole receptacles that accept the tool's plug.
- e) **When operating a power tool outdoors, use an extension cord suitable for outdoor use.** Use of a cord suitable for outdoor use reduces the risk of electric shock. When using an extension cord, be sure to use one heavy enough to carry the current your product will draw. An undersized cord will cause a drop in line voltage resulting in loss of power and overheating. The following table shows the correct size to use depending on cord length and nameplate ampere rating. If in doubt, use the next heavier gauge. The smaller the gauge number, the heavier the cord.

——— direct current  
 ⚠ Class I Construction  
 (grounded)  
 □ Class II Construction  
 (double insulated)  
 BPM.....beats per minute

$n_0$ ..... no load speed  
 ⊕..... earthing terminal  
 ▲..... safety alert symbol  
 .../min ..... revolutions or reciprocation  
 per minute

## SAVE THESE INSTRUCTIONS

### Motor

Your DEWALT tool is powered by a DEWALT built motor. Be sure your power supply agrees with the nameplate marking. Voltage decrease of more than 10% will cause loss of power and overheating. All DEWALT tools are factory tested; if this tool does not operate, check the power supply.

### COMPONENTS (Fig. 1)

- A. Trigger switch/variable speed switch
- B. Swivel head shear
- C. Lock-on control button
- D. Blade

### Variable Speed Switch (Fig. 1)

To turn the tool ON, squeeze the trigger switch (A). To turn the tool OFF release the trigger. Your tool is equipped with a **variable speed switch** which enables you to select the best speed for a particular application. The farther you squeeze the trigger, the faster the tool will operate. Use lower speeds for cutting tight curves or following precise guideline. Higher speeds are better for gradual curves and straight line cuts. For maximum tool life, use lower speeds only for short periods of time.

### Lock-On Button (Fig. 1, 2)

**▲ WARNING: To reduce the risk of serious personal injury, be sure to release the switch lock button before disconnecting the plug from the power supply. Failure to do so will cause the tool to start immediately the next time it is plugged in. Damage or injury could result.**

**To lock the trigger in the on position for continuous operation,** depress trigger, push up the lock button, and gently release the trigger.

**To release the locking mechanism,** depress the trigger fully, then release it. Before using the tool each time, be sure that the lock button release mechanism is working freely..

### OPERATION

**▲ WARNING: To reduce the risk of serious personal injury, turn tool off and disconnect tool from power source before installing and removing accessories, before adjusting or when making repairs. To prevent inadvertant operation, lock the trigger switch when the tool is not in use and when storing the tool.**

For accurate work, always clamp or anchor the material to be cut. Line up one edge of the tool's middle blade with the cutting line and advance blades into the material without forced effort or unnecessary pressure. A little practice will enable you to determine what forward pressure gives you the smoothest cutting. It is important to keep the lower surfaces of the side blades flat on the material being cut (Fig. 5). When cutting curves, do not tilt the tool; keep the side blades flat and level. The head of the shear will swivel to afford better access to the material. For best cutting efficiency, keep blades sharp.

### Disassembly and Assembly

**To remove shear head from motor,** loosen three cap screws (E) using the hex wrench (F) provided. Remove shear head (B) by pulling head firmly forward. Slight twisting action may be required if head does not slide off easily.

**To remove cutter blades from shear head,** remove three cap screws (E) from shear housing (G). Be careful not to lose rear spacer bushing when removing middle cap screw. Remove center blade (H) from housing by tapping blade gently towards the rear. The side knives (I) and side spacers (J) will now drop out of the housing.

**To remove eccentric bearing assembly from shaft,** use an appropriate wrench to loosen eccentric nut (K) by turning counterclockwise.

**To install eccentric bearing assembly onto shaft,** make sure the large, thin washer (L) is first inserted over shaft. Screw eccentric bearing assembly onto shaft and tighten with appropriate wrench. Lubricate bearing (N) with a good grade of bearing grease.

**To install cutter blades into shear housing,** place the side knives (I) and side spacers (J) into position in the shear housing (H). Insert center cap screw through side knife and side spacer with rear spacer bushing between them. Start cap screw into thread just enough to hold blades in place. **DO NOT TIGHTEN.** Insert spacer bushing into hole in center blade and lubricate. Install center blade into shear housing by tapping blade gently forward using a drift pin to line up hole in center blade with forward holes in housing. Insert and tighten forward cap screw making sure spacer bushing in center blade stays in position. Apply good grade of bearing grease to clevis or yoke in center blade where it rides on the eccentric bearing assembly. Insert rear cap screw into shear housing but do not completely tighten.

**To install shear head assembly onto drive motor,** make sure all cap screws are loosened about 3 or 4 complete turns. Place shear head onto unit and alternately tighten cap screws snugly to lock head assembly in place. It may be necessary to gently tap the shear head into place if it does not readily slip onto the nose of the power unit.

### Adjustment (Fig. 5, 6)

#### SWIVEL HEAD

To better accommodate safe cutting at any angle, the shear head can be repositioned by loosening the three cap screws.

Once the screws are loosened, turn the shear head to the desired angle. Retighten the three cap screws before installing battery pack.

To adjust the curl of waste material, the left side knife has elongated holes. Adjustment may be necessary after changing blades or material being cut. Loosen cap screws and tap side knife either forward or backward so that curl of waste does not hit shear housing or work material while cutting.

### MAINTENANCE

**▲ WARNING: To reduce the risk of serious personal injury, turn tool off and disconnect tool from power source before installing and removing accessories, before adjusting or when making repairs. To prevent inadvertant operation, lock the trigger switch when the tool is not in use and when storing the tool.**

#### Cleaning

**▲ WARNING: Blow dirt and dust out of all air vents with dry air at least once a week. Wear proper ANSI Z87.1 (CAN/CSA Z94.3) eye protection and proper NIOSH/OSHA/MSHA respiratory protection when performing this.**

**▲ WARNING: Never use solvents or other harsh chemicals for cleaning the non-metallic parts of the tool. These chemicals may weaken the plastic materials used in these parts. Use a cloth dampened only with water and mild soap. Never let any liquid get inside the tool; never immerse any part of the tool into a liquid.**

#### Lubrication

All ball bearings are factory lubricated to last the life of the tool. All sleeve and needle bearings receive their lubrication from grease in the gear case. Clean and re-lubricate gear case yearly or whenever servicing requires the gear case to be removed. Use type and quantity of grease shown on the parts bulletin packed with your tool.

#### Repairs

To assure product SAFETY and RELIABILITY, repairs, maintenance and adjustments (including brush inspection and replacement) should be performed by a DEWALT factory service center, a DEWALT authorized service center or other qualified service personnel. Always use identical replacement parts.

#### Accessories

**▲ WARNING: Since accessories, other than those offered by DEWALT, have not been tested with this product, use of such accessories with this tool could be hazardous. To reduce the risk of injury, only DEWALT, recommended accessories should be used with this product.**

FIG. 1

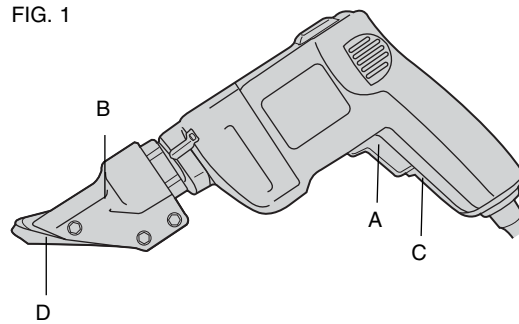

FIG. 2

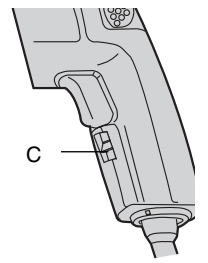

FIG. 3

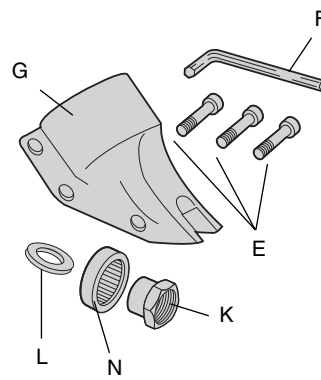

FIG. 4

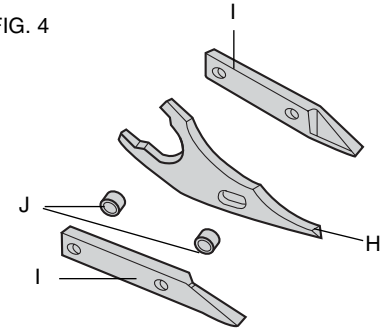

FIG. 4

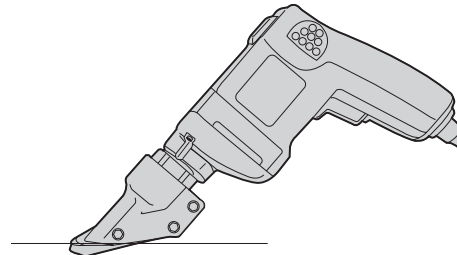

FIG. 5

