

DEWALT®



Instruction Manual

DCR025

Heavy-Duty Bluetooth® Work Site Radio/Charger

Definitions: Safety Alert Symbols and Words

This instruction manual uses the following safety alert symbols and words to alert you to hazardous situations and your risk of personal injury or property damage.



DANGER: Indicates an imminently hazardous situation which, if not avoided, **will** result in **death or serious injury**.



WARNING: Indicates a potentially hazardous situation which, if not avoided, **could** result in **death or serious injury**.



CAUTION: Indicates a potentially hazardous situation which, if not avoided, **may** result in **minor or moderate injury**.



(Used without word) Indicates a safety related message.

NOTICE: Indicates a practice **not related to personal injury** which, if not avoided, **may** result in **property damage**.

Fig. A

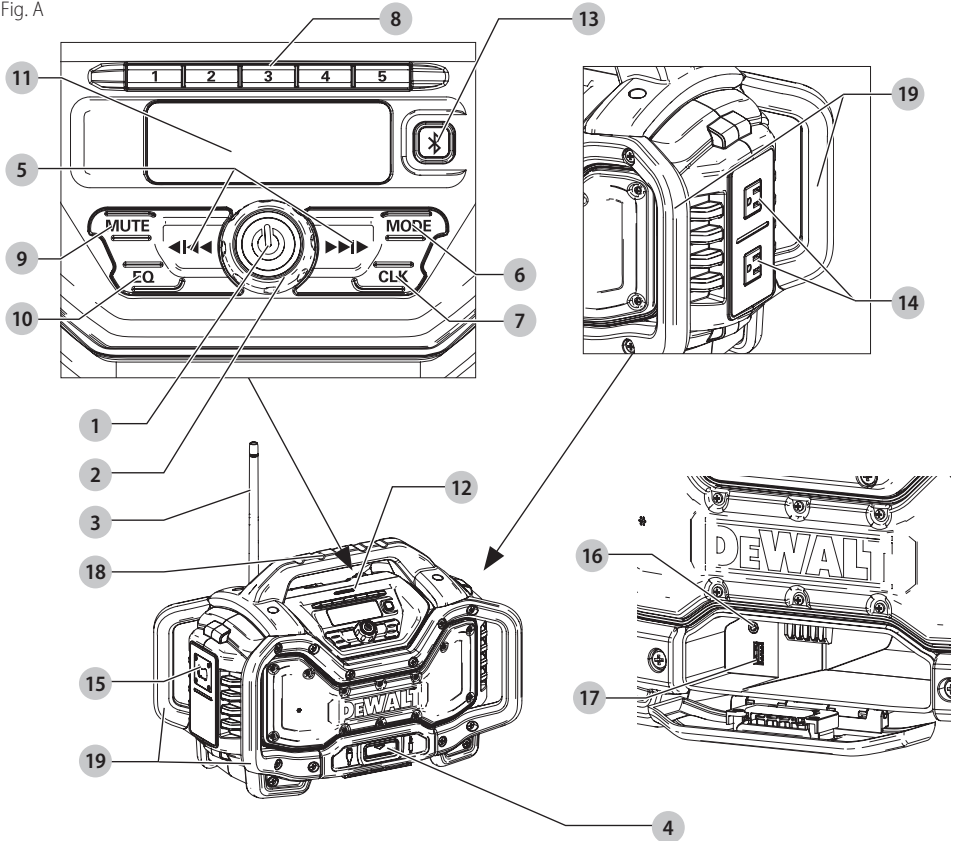

1 ON/OFF button

2 Volume knob

3 Antenna

4 Device storage compartment

5 Seek/tuner/arrow buttons

6 Mode button

7 Clock button

8 Radio preset buttons

9 Mute button

10 EQ button

11 LCD display

12 Charging indicator light

13 Bluetooth button

14 AC outlet

15 Bottle opener

16 AUX audio port

17 USB charging port

18 Carry handle

19 Roll cage



WARNING! Read all safety warnings and all instructions. Failure to follow the warnings and instructions may result in electric shock, fire and/or serious injury.



WARNING: To reduce the risk of injury, read the instruction manual.

DCR025 Heavy-Duty Bluetooth® Work Site Radio/Charger

The DCR025 Heavy-Duty Bluetooth® Work Site Radio Charger is an AM/FM radio. The DCR025 can be powered by 120V AC power source as well as all DeWALT 20V Max* and FLEXVOLT™ Li-Ion battery packs. Batteries sold separately.

SAVE ALL WARNINGS AND INSTRUCTIONS FOR FUTURE REFERENCE

Important Safety Instructions













WARNING: Read all safety warnings and all instructions. Failure to follow the warnings and instructions may result in electric shock, fire and/or serious injury.

1. **Read these instructions.**
2. **Keep these instructions.**
3. **Heed all warnings.**
4. **Follow all instructions.**
5. **Do not use this apparatus near water.**
6. **Clean only with a dry cloth.**
7. **Do not block any ventilation openings.** Install in accordance with the manufacturer's instructions.
8. **Do not install near any heat sources such as radiators, heat registers, stoves or other apparatus (including amplifiers) that produce heat.**
9. **Do not defeat the safety purpose of the polarized or grounding-type plug.** A polarized plug has two blades with one wider than the other. A grounding type plug has two blades and a third grounding prong. The wide blade or the third prong are provided for your safety. If the provided plug does not fit into your outlet, consult an electrician for replacement of the obsolete outlet.
10. **Protect the power cord from being walked on or pinched particularly at plugs, convenience receptacles, and the point where they exit from the apparatus.**
11. **Only use attachments/accessories specified by the manufacturer.**
12. **Unplug this apparatus during lightning storms or when unused for long periods of time.**
13. **Refer all servicing to qualified service personnel.** Servicing is required when the apparatus has been damaged in any way, such as power-supply cord or plug is damaged, liquid has been spilled or objects have fallen into the apparatus, the apparatus has been exposed to rain or moisture, does not operate normally, or has been dropped.
14. **Apparatus shall not be exposed to dripping or splashing and no objects filled with liquids, such as vases, shall be placed on the apparatus**

WARNING: To reduce the risk of fire or electric shock, do not expose this apparatus to rain or moisture. Use only in dry locations.

WARNING: To prevent electric shock, match wide blade of plug to wide slot of outlet.

The label on your tool may include the following symbols. The symbols and their definitions are as follows:

V	volts		or AC/DC... alternating or direct current
Hz	hertz	 Class II Construction (double insulated)
min	minutes	n_0	no load speed
 or DC.....	direct current	n	rated speed
 Class I Construction (grounded)	 earthing terminal
.../min.....	per minute	 safety alert symbol
BPM	beats per minute	 visible radiation
IPM	impacts per minute	 wear respiratory protection
RPM	revolutions per minute	 wear eye protection
sfpm	surface feet per minute	 wear hearing protection
SPM	strokes per minute	 read all documentation
A	amperes		
W	watts		
 or AC.....	alternating current		

BATTERIES AND CHARGERS

The battery pack is not fully charged out of the carton. Before using the battery pack and charger, read the safety instructions below and then follow charging procedures outlined. When ordering replacement battery packs, be sure to include the catalog number and voltage. Your radio is a DeWALT charger. Be sure to read all safety instructions before using your charger. Consult the chart at the end of this manual for compatibility of chargers and battery packs.

READ ALL INSTRUCTIONS

Important Safety Instructions for All Battery Packs

WARNING: Read all safety warnings and all instructions for the battery pack, charger and power tool. Failure to follow the warnings and instructions may result in electric shock, fire and/or serious injury.

- **Do not charge or use the battery pack in explosive atmospheres, such as in the presence of flammable liquids, gases or dust.** Inserting or removing the battery pack from the charger may ignite the dust or fumes.
- **NEVER force the battery pack into the charger. DO NOT modify the battery pack in any way to fit into a non-compatible charger as battery pack may rupture causing serious personal injury.** Consult the chart at the end of this manual for compatibility of batteries and chargers.
- Charge the battery packs only in designated DeWALT chargers.
- **DO NOT splash or immerse in water or other liquids.**

- **Do not store or use the tool and battery pack in locations where the temperature may reach or exceed 104 °F (40 °C) (such as outside sheds or metal buildings in summer).** For best life store battery packs in a cool, dry location.

NOTE: Do not store the battery packs in a tool with the trigger switch locked on. Never tape the trigger switch in the ON position.

- **Do not incinerate the battery pack even if it is severely damaged or is completely worn out.** The battery pack can explode in a fire. Toxic fumes and materials are created when lithium ion battery packs are burned.
- **If battery contents come into contact with the skin, immediately wash area with mild soap and water.** If battery liquid gets into the eye, rinse water over the open eye for 15 minutes or until irritation ceases. If medical attention is needed, the battery electrolyte is composed of a mixture of liquid organic carbonates and lithium salts.
- **Contents of opened battery cells may cause respiratory irritation.** Provide fresh air. If symptoms persist, seek medical attention.



WARNING: Burn hazard. Battery liquid may be flammable if exposed to spark or flame.



WARNING: Fire hazard. Never attempt to open the battery pack for any reason. If the battery pack case is cracked or damaged, do not insert into the charger. Do not crush, drop or damage the battery pack. Do not use a battery pack or charger that has received a sharp blow, been dropped, run over or damaged in any way (e.g., pierced with a nail, hit with a hammer, stepped on). Damaged battery packs should be returned to the service center for recycling.

Transportation



WARNING: Fire hazard. Do not store or carry the battery pack so that metal objects can contact exposed battery terminals. For example, do not place the battery pack in aprons, pockets, tool boxes, product kit boxes, drawers, etc., with loose nails, screws, keys, etc. **Transporting batteries can possibly cause fires if the battery terminals inadvertently come in contact with conductive materials such as keys, coins, hand tools and the like.** The US Department of Transportation Hazardous Material Regulations (HMR) actually prohibit transporting batteries in commerce or on airplanes in carry-on baggage UNLESS they are properly protected from short circuits. So when transporting individual battery packs, make sure that the battery terminals are protected and well insulated from materials that could contact them and cause a short circuit.

Shipping the DeWALT FLEXVOLT™ Battery

The DeWALT FLEXVOLT™ battery has two modes: **Use** and **Shipping**.

Use Mode: When the FLEXVOLT™ battery stands alone or is in a DeWALT 20V Max* product, it will operate as a 20V Max* battery. When the FLEXVOLT™ battery is in a 60V Max* or a 120V Max* (two 60V Max* batteries) product, it will operate as a 60V Max* battery.

Shipping Mode: When the cap is attached to the FLEXVOLT™ battery, the battery is in Shipping Mode. Strings of cells are

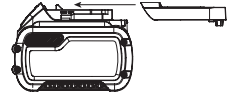

electrically disconnected within the pack resulting in three batteries with a lower watt hour (Wh) rating as compared to one battery with a higher Watt hour rating. This increased quantity of three batteries with the lower watt hour rating can exempt the pack from certain shipping regulations that are imposed upon the higher Watt hour batteries.

The battery label indicates two Watt Hour Ratings (see example). Depending on how the battery is shipped, the appropriate Whr rating must be used to determine the applicable shipping requirements. If utilizing the shipping cap, the pack will be considered 3 batteries at the Whr indicated for "Shipping". If shipping without the cap or in a tool, the pack will be considered one battery at the Watt hour rating indicated next to "Use".

Example of Use and Shipping Label Marking

USE: 120 Wh Shipping: 3 x 40 Wh

For example, shipping Wh rating might indicate 3 x 40 Wh, meaning 3 batteries of 40 Watt hours each. The Use Wh rating might indicate 120 Watt hour (1 battery implied).

Fuel Gauge Battery Packs (Fig. B)

Some DeWALT battery packs include a fuel gauge which consists of three green LED lights that indicate the level of charge remaining in the battery pack.

The fuel gauge is an indication of approximate levels of charge remaining in the battery pack according to the following indicators:

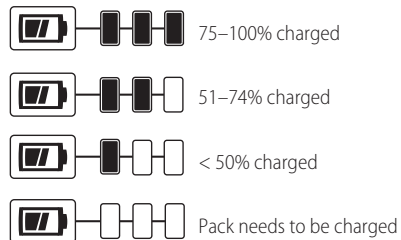

To actuate the fuel gauge, press and hold the fuel gauge button. A combination of the three green LED lights will illuminate designating the level of charge left. When the level of charge in the battery is below the usable limit, the fuel gauge will not illuminate and the battery will need to be recharged.

ENGLISH

Fig. B

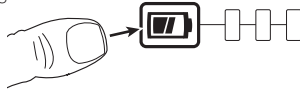

NOTE: The fuel gauge is only an indication of the charge left on the battery pack. It does not indicate tool functionality and is subject to variation based on product components, temperature and end-user application.

The RBRC® Seal

The RBRC® (Rechargeable Battery Recycling Corporation) Seal on the nickel cadmium, nickel metal hydride or lithium-ion batteries (or battery packs) indicates that the costs to recycle these batteries (or battery packs) at the end of their useful life have already been paid by DEWALT. In some areas, it is illegal to place spent nickel cadmium, nickel metal hydride or lithium-ion batteries in the trash or municipal solid waste stream and the Call 2 Recycle® program provides an environmentally conscious alternative.

Call 2 Recycle, Inc., in cooperation with DEWALT and other battery users, has established the program in the United States and Canada to facilitate the collection of spent nickel cadmium, nickel metal hydride or lithium-ion batteries. Help protect our environment and conserve natural resources by returning the spent nickel cadmium, nickel metal hydride or lithium-ion batteries to an authorized DEWALT service center or to your local retailer for recycling. You may also contact your local recycling center for information on where to drop off the spent battery. RBRC® is a registered trademark of Call 2 Recycle, Inc.

RBRC™ is a registered trademark of the Rechargeable Battery Recycling Corporation.

Important Safety Instructions for All Battery Chargers



WARNING: Read all safety warnings and all instructions for the battery pack, charger and power tool. Failure to follow the warnings and instructions may result in electric shock, fire and/or serious injury.

- **DO NOT attempt to charge the battery pack with any chargers other than the ones in this manual.** The charger and battery pack are specifically designed to work together.
- **These chargers are not intended for any uses other than charging DEWALT rechargeable batteries.** Any other uses may result in risk of fire, electric shock or electrocution.
- **Do not expose the charger to rain or snow.**
- **Pull by the plug rather than the cord when disconnecting the charger.** This will reduce the risk of damage to the electric plug and cord.

- **Make sure that the cord is located so that it will not be stepped on, tripped over or otherwise subjected to damage or stress.**
- **Do not use an extension cord unless it is absolutely necessary.** Use of improper extension cord could result in risk of fire, electric shock or electrocution.
- **When operating a charger outdoors, always provide a dry location and use an extension cord suitable for outdoor use.** Use of a cord suitable for outdoor use reduces the risk of electric shock.
- **An extension cord must have adequate wire size (AWG or American Wire Gauge) for safety.** The smaller the gauge number of the wire, the greater the capacity of the cable, that is, 16 gauge has more capacity than 18 gauge. An undersized cord will cause a drop in line voltage resulting in loss of power and overheating. When using more than one extension to make up the total length, be sure each individual extension contains at least the minimum wire size. The following table shows the correct size to use depending on cord length and nameplate ampere rating. If in doubt, use the next heavier gauge. The lower the gauge number, the heavier the cord.

Minimum Gauge for Cord Sets

Volts	Total Length of Cord in Feet (meters)				
	120 V	25 (7.6)	50 (15.2)	100 (30.5)	150 (45.7)
240 V	50 (15.2)	100 (30.5)	200 (61.0)	300 (91.4)	
Ampere Rating		American Wire Gauge			
More Than	Not More Than				
0	6	18	16	16	14
6	10	18	16	14	12
10	12	16	16	14	12
12	16	14	12	Not Recommended	

- **Do not place any object on top of the charger or place the charger on a soft surface that might block the ventilation slots and result in excessive internal heat.** Place the charger in a position away from any heat source. The charger is ventilated through slots in the top and the bottom of the housing.
- **Do not operate the charger with a damaged cord or plug.**
- **Do not operate the charger if it has received a sharp blow, been dropped or otherwise damaged in any way.** Take it to an authorized service center.
- **Do not disassemble the charger; take it to an authorized service center when service or repair is required.** Incorrect reassembly may result in a risk of electric shock, electrocution or fire.
- **Disconnect the charger from the outlet before attempting any cleaning. This will reduce the risk of electric shock.** Removing the battery pack will not reduce this risk.
- **NEVER attempt to connect 2 chargers together.**
- **The charger is designed to operate on standard 120V household electrical power. Do not attempt to**

use it on any other voltage. This does not apply to the vehicular charger.

WARNING: Shock hazard. Do not allow any liquid to get inside the charger. Electric shock may result.

WARNING: Burn hazard. Do not submerge the battery pack in any liquid or allow any liquid to enter the battery pack. Never attempt to open the battery pack for any reason. If the plastic housing of the battery pack breaks or cracks, return to a service center for recycling.

CAUTION: Burn hazard. To reduce the risk of injury, charge only DEWALT rechargeable battery packs. Other types of batteries may overheat and burst resulting in personal injury and property damage.

NOTICE: Under certain conditions, with the charger plugged into the power supply, the charger can be shorted by foreign material. Foreign materials of a conductive nature, such as, but not limited to, grinding dust, metal chips, steel wool, aluminum foil or any buildup of metallic particles should be kept away from the charger cavities. Always unplug the charger from the power supply when there is no battery pack in the cavity. Unplug the charger before attempting to clean.

Charging a Battery (Fig. C)

When the radio is plugged in it will charge the installed battery. Unplugged, the radio will run up to 8 hours on a fully charged battery using a premium 20 V Max* Li-Ion battery. Using batteries of lower voltage and amp hours will yield less run time.

1. Plug the charger into an appropriate outlet before inserting battery pack.

Fig. C

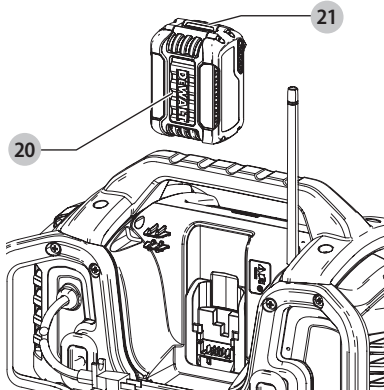

2. Insert the battery pack **20** into the charger, making sure the battery pack is fully seated in the charger. The red (charging) light will blink continuously indicating that the charging process has started.
3. The completion of charge will be indicated by the red light remaining ON continuously. The battery pack is fully charged and may be used at this time or left in the charger. To remove the battery pack from the charger, push the battery release button **21** on the battery pack.

NOTE: To ensure maximum performance and life of lithium-ion battery packs, charge the battery pack fully before first use.

Charger Operation

Refer to the indicators below for the charge status of the battery pack.

DCB101, DCR015, DCR025	
	Charging - - - - -
	Fully Charged —————
	Hot/Cold Pack Delay - • - • - • - •
	Problem Pack or Charger* • • • • • • • •
*DCB101, DCR015 only.	
DCB107, DCB112, DCB113, DCB115, DCB118, DCB132	
	Charging - - - - -
	Fully Charged —————
	Hot/Cold Pack Delay* - - - - —————

*DCB107, DCB112, DCB113, DCB115, DCB118, DCB132:

The red light will continue to blink, but a yellow indicator light will be illuminated during this operation. Once the battery pack has reached an appropriate temperature, the yellow light will turn off and the charger will resume the charging procedure.

The compatible charger(s) will not charge a faulty battery pack. The charger will indicate faulty battery pack by refusing to light or by displaying a problem pack or charger blink pattern.

NOTE: This could also mean a problem with a charger.

If the charger indicates a problem, take the charger and battery pack to be tested at an authorized service center.

Hot/Cold Pack Delay

When the charger detects a battery pack that is too hot or too cold, it automatically starts a Hot/Cold Pack Delay, suspending charging until the battery pack has reached an appropriate temperature. The charger then automatically switches to the pack charging mode. This feature ensures maximum battery pack life.

A cold battery pack will charge at a slower rate than a warm battery pack. The battery pack will charge at that slower rate throughout the entire charging cycle and will not return to maximum charge rate even if the battery pack warms.

The DCB118 charger is equipped with an internal fan designed to cool the battery pack. The fan will turn on automatically when the battery pack needs to be cooled.

Never operate the charger if the fan does not operate properly or if ventilation slots are blocked. Do not permit foreign objects to enter the interior of the charger.

Electronic Protection System

Li-Ion tools are designed with an Electronic Protection System that will protect the battery pack against overloading, overheating or deep discharge.

ENGLISH

The tool will automatically turn off if the Electronic Protection System engages. If this occurs, place the lithium-ion battery pack on the charger until it is fully charged.

Charger Cleaning Instructions



WARNING: Shock hazard. Disconnect the charger from the AC outlet before cleaning. Dirt and grease may be removed from the exterior of the charger using a cloth or soft non-metallic brush. Do not use water or any cleaning solutions.

Important Charging Notes

1. Longest life and best performance can be obtained if the battery pack is charged when the air temperature is between 65 °F and 75 °F (18 °–24 °C). DO NOT charge the battery pack in an air temperature below +40 °F (+4.5 °C), or above +104 °F (+40 °C). This is important and will prevent serious damage to the battery pack.
2. The charger and battery pack may become warm to the touch while charging. This is a normal condition, and does not indicate a problem. To facilitate the cooling of the battery pack after use, avoid placing the charger or battery pack in a warm environment such as in a metal shed or an uninsulated trailer.
3. If the battery pack does not charge properly:
 - a. Check operation of receptacle by plugging in a lamp or other appliance;
 - b. Check to see if receptacle is connected to a light switch which turns power off when you turn out the lights;
 - c. Move the charger and battery pack to a location where the surrounding air temperature is approximately 65 °F – 75 °F (18 °–24 °C);
 - d. If charging problems persist, take the tool, battery pack and charger to your local service center.
4. The battery pack should be recharged when it fails to produce sufficient power on jobs which were easily done previously. DO NOT CONTINUE to use under these conditions. Follow the charging procedure. You may also charge a partially used pack whenever you desire with no adverse effect on the battery pack.
5. Foreign materials of a conductive nature such as, but not limited to, grinding dust, metal chips, steel wool, aluminum foil, or any buildup of metallic particles should be kept away from charger cavities. Always unplug the charger from the power supply when there is no battery pack in the cavity. Unplug the charger before attempting to clean.
6. Do not freeze or immerse the charger in water or any other liquid.

Storage Recommendations

1. The best storage place is one that is cool and dry, away from direct sunlight and excess heat or cold.
2. For long storage, it is recommended to store a fully charged battery pack in a cool dry place out of the charger for optimal results.

NOTE: Battery packs should not be stored completely depleted of charge. The battery pack will need to be recharged before use.

SAVE THESE INSTRUCTIONS FOR FUTURE USE

1. This device complies with Part 15 of the FCC Rules and Industry Canada License-exempt RSS standard(s). Operation is subject to the following two conditions:
 - a. This device may not cause harmful interference, and
 - b. This device must accept any interference received, including interference that may cause undesired operation.
2. Changes or modifications not expressly approved by the party responsible for compliance could void the user's authority to operate the equipment.
3. This equipment has been tested and found to comply with the limits for a Class B digital device, pursuant to Part 15 of the FCC Rules. These limits are designed to provide reasonable protection against harmful interference in a residential installation. This equipment generates, uses, and can radiate radio frequency energy and, if not installed and used in accordance with the instructions, may cause harmful interference to radio communications. However, there is no guarantee that interference will not occur in a particular installation. If this equipment does cause harmful interference to radio or television reception, which can be determined by turning the equipment off and on, the user is encouraged to try to correct the interference by one of the following measures:
 - Reorient or relocate the receiving antenna.
 - Increase the separation between the equipment and receiver.
 - Connect the equipment into an outlet on a circuit different from that to which the receiver is connected.
 - Consult the dealer or an experienced radio/TV technician for help.
4. CAN ICES-3 (B)/NMB-3(B)
5. Under Industry Canada regulations, this radio transmitter may only operate using an antenna of a type and maximum (or lesser) gain approved for the transmitter by Industry Canada. To reduce potential radio interference to other users, the antenna type and its gain should be so chosen that the equivalent isotropically radiated power (e.i.r.p) is not more than that necessary for successful communication.
6. To comply with FCC and Industry Canada RF radiation exposure limits for general population, the antenna used for this device must not be co-located or operating in conjunction with any other antenna or transmitter.

COMPONENTS (FIG. A)



WARNING: Never modify the power tool or any part of it. Damage or personal injury could result.

Refer to Figure A at the beginning of this manual for a complete list of components.

Intended Use

This DeWALT Bluetooth® radio/charger is designed for broadcast radio reception or to play/stream audio via a wireless Bluetooth® connection or wired connection to a mobile phone or other audio device and charge DeWALT batteries.

DO NOT use under wet conditions or in presence of flammable liquids or gases.

DO NOT let children come into contact with the tool. Supervision is required when inexperienced operators use this tool.

ASSEMBLY AND ADJUSTMENTS

! **WARNING:** To reduce the risk of serious personal injury, turn unit off and remove the battery pack before making any adjustments or removing/installing attachments or accessories. An accidental start-up can cause injury.

To Install Coin Cell Battery (Fig. D)

! **WARNING:** Danger of explosion if battery is incorrectly replaced. When replacing battery, replace it with the same or equivalent type CR2032. Observe correct polarity (+ and -) when replacing batteries. Do not store or carry batteries so that metal objects can contact exposed battery terminals.

1. On the battery door on the back of the unit, turn the screw **22** counterclockwise to remove. Screw will remain captive in the door.

Fig. D

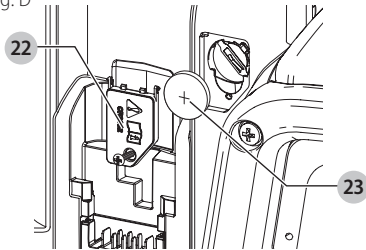

2. Press down on the battery door latch and pull to open.
3. Install the coin cell battery **23** according to the diagram inside the coin cell battery area.
4. Replace the battery door, insert the screw and tighten.

NOTE: To reset the LCD display, clock, and pre-sets remove the coin cell battery and re-install. Follow this procedure if the screen seems to lock in place.

! **DANGER: DO NOT INGEST BATTERY; CHEMICAL BURN HAZARD.** This product contains a coin/button cell battery. If the coin/button cell battery is swallowed, it can cause severe internal burns in just 2 hours and can lead to death. Keep new and used batteries away from children. If the battery compartment does not close securely stop using the product and keep it away from children. If you think batteries might have been swallowed or placed inside any part of the body, seek immediate medical attention.

OPERATION

! **WARNING:** To reduce the risk of serious personal injury, turn unit off and remove the battery pack before making any adjustments or removing/installing attachments or accessories. An accidental start-up can cause injury.

Your Bluetooth® radio/charger is equipped with memory capacity in order to store the time and your selected memory channels. When the radio is in the OFF position, this memory capacity is powered by one coin cell battery that is included with the radio/charger.

Power/Volume Adjustment

1. To turn the radio on and off, press the ON/OFF button **1**.
2. Turn the dial **2** clockwise to increase the volume. To decrease the volume, turn counterclockwise. Note the volume can also be muted by pressing the mute button **9**.

Mode Function

To choose one of the mode functions (FM1, FM2, AM, AUX or Bluetooth) push the mode button **6** until the desired function is found.

NOTE: Pressing the Bluetooth button **13** also puts the radio into Bluetooth mode.

Tune or Seek Function

There are two tuning methods and one seek method for finding the desired frequency.

To tune:

Press and release the right or left arrow button **5**. Repeat until the desired frequency is found.

To seek:

Press and hold the right or left arrow button **5** for 2 seconds. The tuner frequency will change to the first radio station with acceptable clarity and stop at that station.

NOTE: When the radio/charger is paired to a Bluetooth® device the right and left arrow buttons **5** can be used to skip or go to previous tracks on the audio device.

To Program the Clock

1. Power on the radio.
2. Press the clock button. The date and time will be displayed, and the year will begin to blink.
3. Use the clock button to pick the parameter of time desired and use the right and left arrows to adjust.

NOTE: If you do not press a button within 5 seconds, the clock programming feature will automatically return to the previous setting.

To Program the Memory Buttons

Ten FM and five AM radio stations may be independently set. After programming the buttons, pressing 1, 2, 3, 4 or 5 will instantly change the frequency to the preset station.

1. Turn power on.
2. Set the radio to desired station (see **Tune or Seek Function**).

ENGLISH

- Press and hold one of the desired memory preset buttons **8** until the button number appears on the right side of the LCD. The preset button is now set.
- Repeat steps 2 and 3 to set the other preset buttons.

To Adjust the EQ

Sound quality can be adjusted by changing the equalization of the bass or treble of the radio.

- Press the EQ button **10** to select bass or treble.
- Press the right arrow **5** button to increase the selected setting or the left arrow **5** button to decrease it.
- Once desired adjustment is achieved, leave all buttons released for more than 3 seconds. The procedure will exit and the equalization adjustment will remain activated.

Playing Audio Through an External Device (Fig. A, E)

Audio can be played through the radio/charger via a wireless Bluetooth® connection to a compatible Bluetooth® device or by connecting audio device or mobile phone using a 1/8" (3.5 mm) audio cable to the audio port **16** located inside the device storage compartment **4**.

Fig. E

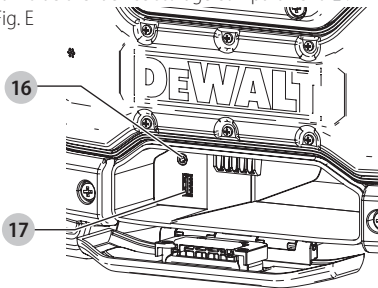

Pairing Radio/charger with a Bluetooth® Audio Device

- Place the radio/charger and the Bluetooth® audio source within 3.3' (1 m) of each other.
- Turn radio/charger on by pressing the power button **1**.
- Press the Bluetooth® button **13** or use the mode button to put the unit into Bluetooth® (BT) mode. This will cause the Bluetooth button to blink slowly. During this time, the radio is trying to find a previously paired device. If found the Bluetooth button will stay lit without any blinking.
- If another device is to be paired, press the Bluetooth button and it should begin a fast blink pattern. While the radio is displaying the fast blink, it is in pairing mode.
- Confirm pairing on your device. (Please consult your device's instruction manual for specific pairing instructions.)

NOTE: If pairing is not confirmed within 2 minutes, the LED will stop flashing and the radio/charger will return to half second interval blink pattern.

- Once pairing is successful the Bluetooth® indicator/button **13** will turn solid and the radio/charger will emit a short tone. The radio/charger will now play music from your device.

Bluetooth Status Indicator

LED indicator	Status/Mode
Steady blinking (half second interval)	radio/charger is unpaired or in connecting mode.
Rapid Blinking	radio/charger is in pairing mode and discoverable by your device.
Solid light	radio/charger is connected with a device.
No light	radio/charger has timed out and/or is off.

Connecting a Previously Paired Bluetooth® Audio Device

If a Bluetooth® device has been previously paired to the radio/charger it should automatically reconnect when radio/charger is powered on. After 4 seconds the radio/charger will go into connecting mode. This is indicated by the Bluetooth® indicator/button **13** blinking steady. Once the previously paired Bluetooth® device is recognized and connected, the LED will go solid. If connection does not occur and you are unable to stream music please follow the instructions for **Pairing Radio/charger with a Bluetooth® Audio Device**.

Timeout Functionality (Fig. A)

To conserve battery life the radio/charger is designed to power off automatically after an hour of inactivity. This inactivity could be due to the device being unpaired for an hour or in the case of the Bluetooth® connection being broken for the same period of time. If the radio/charger powers off due to inactivity of any kind refer to **Connecting a Previously Paired Bluetooth® Audio Device**.

NOTE: Optimum Bluetooth® streaming range is roughly 30 ft (9 m) (line of sight) to the radio/charger but distances up to 100 feet (30 m) are possible. Physical obstacles, other wireless devices or electromagnetic devices may affect the connection quality.

If Bluetooth® connection is lost due to exceeding time of separation, exceeding the optimum distance, obstacles or otherwise, reconnecting your device with the radio/charger may be necessary.

Charging a Cell Phone or Audio Device Via USB (Fig. E)

Your audio device or mobile phone can be charged (up to 2.1 AMPS) using the USB power port **17** on the radio/charger. This charging is possible when unit is on, running off of AC plug power or the battery pack.

AC Outlets (Fig. F)

The radio/charger is equipped with 2 AC outlets **14** (10 amp maximum) for powering additional tools or appliances.

Fig. F

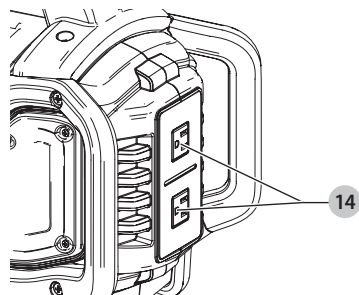

Important Radio Notes

1. Reception will vary depending on location and strength of radio signal.
2. Running the radio while connected to certain generators may cause background noise.
3. AM reception will most likely be clearer when powered by a battery pack.

MAINTENANCE

WARNING: To reduce the risk of serious personal injury, turn unit off and remove the battery pack before making any adjustments or removing/installing attachments or accessories. An accidental start-up can cause injury.

Cleaning

WARNING: Blow dirt and dust out of all air vents with clean, dry air at least once a week. To minimize the risk of eye injury, always wear ANSI Z87.1 approved eye protection when performing this.

WARNING: Never use solvents or other harsh chemicals for cleaning the non-metallic parts of the tool. These chemicals may weaken the plastic materials used in these parts. Never let any liquid get inside the tool; never immerse any part of the tool into a liquid.

Accessories

WARNING: Since accessories, other than those offered by DEWALT, have not been tested with this product, use of such accessories with this tool could be hazardous. To reduce the risk of injury, only DEWALT recommended accessories should be used with this product.

Repairs

The radio/charger and battery pack are not serviceable.

WARNING: To assure product SAFETY and RELIABILITY, repairs, maintenance and adjustment (including brush inspection and replacement) should be performed by a DEWALT factory service center or a DEWALT authorized service center. Always use identical replacement parts.

Register Online

Thank you for your purchase. Register your product now for:

- **WARRANTY SERVICE:** Registering your product will help you obtain more efficient warranty service in case there is a problem with your product.
- **CONFIRMATION OF OWNERSHIP:** In case of an insurance loss, such as fire, flood or theft, your registration of ownership will serve as your proof of purchase.
- **FOR YOUR SAFETY:** Registering your product will allow us to contact you in the unlikely event a safety notification is required under the Federal Consumer Safety Act.