



Detroit Speed, Inc.
Selecta-Speed Wiper Kit
1968 A-Body – Non Recessed Park
P/N: 121612

A downpour of rain will no longer hinder your ability to clearly see the road. The Detroit Speed Inc. Selecta-Speed Wiper Kit provides you with the performance and convenience of a late model wiper system in a package that easily and cleanly mounts in your 1968 A-Body.



Item #	Description	Quantity
1	Wiper Motor Assembly w/ Adapter Plate	1
2	Wiper Control Module w/ Module Plate	1
3	Wiper Harness	1
4	Wiper Switch Assembly	1
5	Wiper Knob w/Set Screw	1
7	10-24 x 3/4" L Stainless Steel Screws	3
8	3/8" AN Stainless Steel Washer	1
9	7/16" Flat Washer	1
10	Thread Adapter	1
11	Shaft Extension w/Set Screw	1
12	Instructions	1

This kit features a seven speed wiper system with five delays, low speed, and high speed. A CNC aluminum adapter plate mounts the wiper motor to the stock firewall bolt pattern. The new pitman arm, included in the kit, bolts directly to your existing wiper linkage. A rotary switch with a billet aluminum knob is also included, along with a complete wiring harness.

This kit does feature a washer pump option as the wiper switch does have a push button function. The wiring harness/control module is equipped with a power and ground wire to install an inline electric washer pump. DSE does offer a washer pump kit available as part number 121102.

Installation Instructions:

1. Before beginning, please ensure that the parts included with your kit match the parts list above. Ensure that the factory wiper system is in its "Parked" position. Disconnect the battery power by removing the negative battery lead from the battery. Mark the position of the wiper arms by placing masking tape on the windshield. This will assure the arms are accurately replaced. Remove the wiper arms, washer hoses, and cowl panel from the vehicle.
2. Disconnect the wiper linkage from the wiper motor pitman arm and remove the stock wiper motor from the firewall. **NOTE:** For the Can style wiper motors, the factory mounting plate must also be removed from the firewall (Figure 1).



Figure 1 – Remove Factory Mounting Plate

3. The original wiring will not be used with the new Selecta-Speed Wiper Kit. A custom harness is provided to replace the original. **NOTE:** If you decide to cut the old wires please pay special attention to properly terminate the wire ends to avoid possible shorting.
4. Mount the new wiper assembly to the firewall with the three supplied 10-24 x 3/4"L stainless steel allen screws. The adapter plate will mount to the firewall using the original wiper motor weld nuts in the firewall (Figure 2 on the next page). Do **NOT** attach the original wiper linkage to the new pitman arm at this time.

NOTE: The Selecta-Speed kit is shipped with the pitman arm in the "parked" position. If the pitman arm is moved from the original "parked" position from DSE, it may result in the wiper blades stopping in the wrong spot on the windshield.

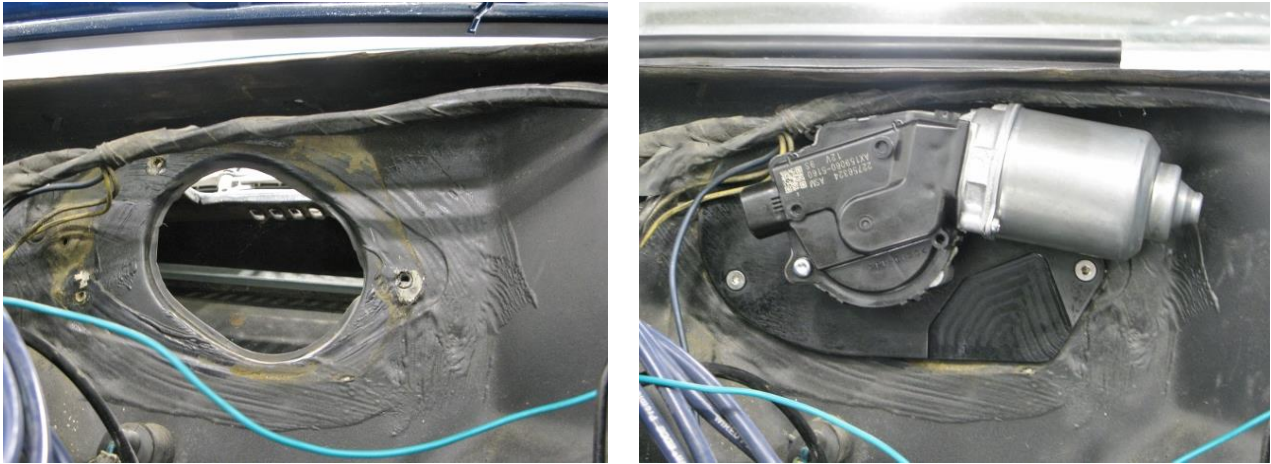

Figure 2 - Wiper Motor Orientation

5. The Selecta-Speed switch will replace the stock switch. Remove the lower column cover from the dash. Remove the stock wiper switch and retainer/bezel from the dash and remove the connector. Tie up the original wiring under the dash, if desired.
6. To mount the switch in the dash, remove the star washer and the hex nut from the switch. Install the 7/16" flat washer over the switch followed by the 3/8" AN stainless steel washer. Install the threaded adapter onto the threads on the switch.
7. Install the switch assembly through the hole in the dash. Using the factory switch retainer/bezel (Figure 3), thread the retainer onto the switch and tighten. Be careful not to overtighten the bezel as damage to the dash could result.



Figure 3 - Wiper Switch Retainer/Bezel

8. Slide the shaft extension onto the switch. Align the set screw with the flat on the switch and tighten. Slide the wiper knob onto the shaft extension. Align the set screw with the flat on the shaft extension and tighten (Figure 4 & 5 on the next page). **NOTE:** Make sure the set screws lock onto the flats on the switch and shaft extension.

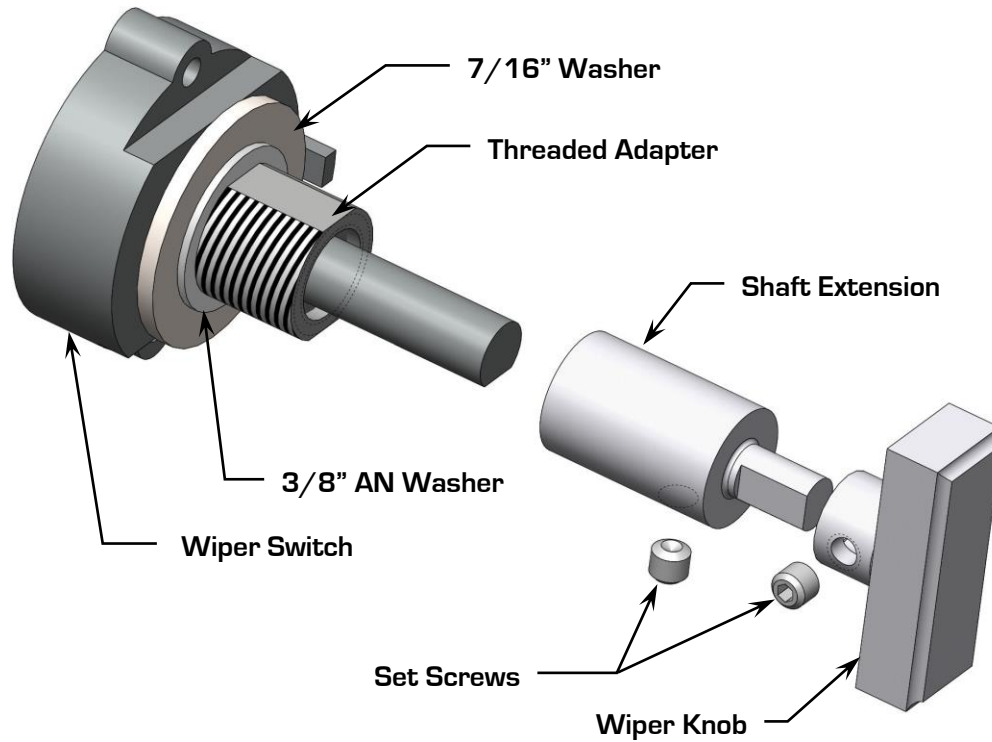

Figure 4 - 1968 Chevelle Wiper Switch Assembly



Figure 5 - 1968 Chevelle Wiper Switch

9. Route the wiper motor connector side of the wiring harness (Figure 6 on the next page) through the firewall using an existing hole. You may need to open up the diameter of this hole using a 1-1/4" drill bit or Uni-Bit in order to allow the wiper motor connector to pass through the firewall.



Figure 6 – Wiper Motor Connector

10. A rubber grommet is already installed on the wire loom for the wiper motor wires. Once there is enough of the loom through the firewall to connect to the wiper motor, move the grommet on the loom and install it into the firewall to seal the engine compartment from the inside of the vehicle.

11. Install the wiper motor connector to the wiper motor (Figure 7).



Figure 7 – Install Wiper Motor Connector

12. The DSE Selecta-Speed harness does include a weather pack connector to install an optional electric inline washer pump into your vehicle (Figure 8). DSE does offer a washer pump kit you can purchase separately as part number 121102.



Figure 8 – Washer Pump Connection

13. If you have purchased the Detroit Speed washer pump kit, use the instructions from that kit to complete the washer pump kit installation. If you do not want to use the washer pump feature, you can tie wrap this connector/loom up under the dash.
14. Install the wiper control module onto the module mounting plate using the provided 8-32 hardware if not already assembled from DSE. Do not over-tighten.
15. Remove the flange nut on the right side of the steering column and install the module and mounting plate (Figure 9). **NOTE:** The module connectors should be pointing towards the firewall.

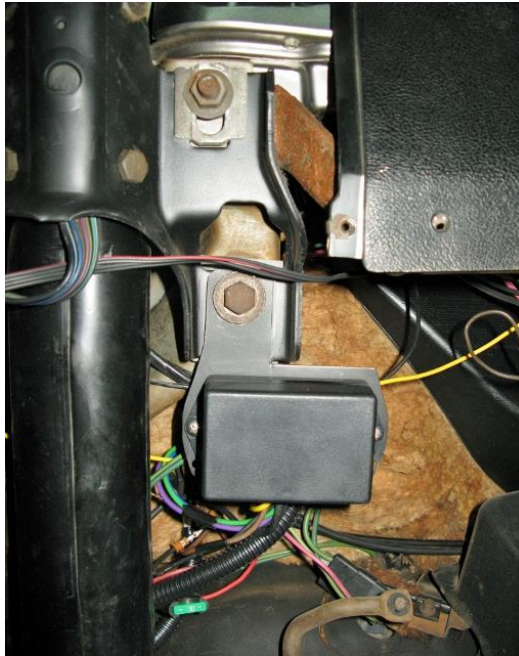

Figure 9 - Install Module & Mounting Plate

16. With the wiper control module in place, plug in the wiper switch and wiring harness connectors into the control module (Figure 10).

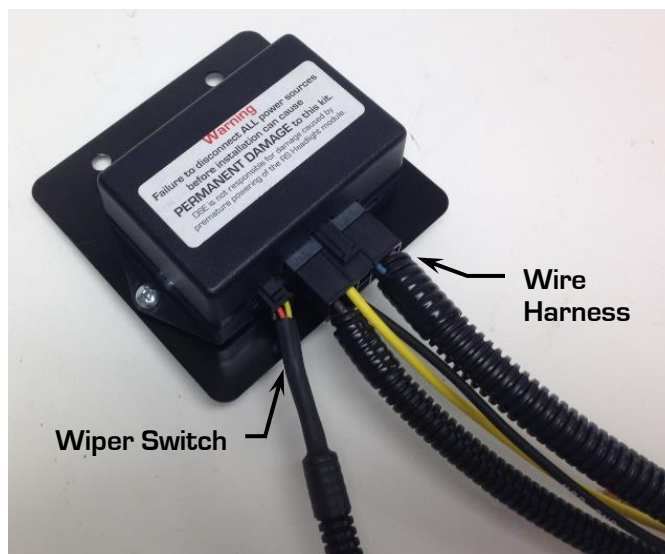

Figure 10 - Connect Wiper Switch & Harness to Module

17. Connect the yellow wire under the dash to a 12V ignition or accessory switched source. (Circuit is active when the key is in the run position). This lead is supplied with an inline 30 amp ATO fuse.

18. Connect the black wire with the round eyelet to a ground located under the dash. Make sure a proper ground is obtained by removing any rust or paint from the metal.
19. Connect the negative battery lead and test the wiper system with the wiper linkage **NOT** attached to the pitman arm. This will allow the pitman arm to cycle once to verify that it is in the “parked” position. **NOTE:** Sitting in the driver’s seat, the pitman arm should be in the 9 o’clock position.
20. Once the pitman arm is in the correct position, attach the new pitman arm to the original wiper linkage (Figure 11). **NOTE:** Do not move the pitman arm by hand to attach the wiper linkage. If the pitman arm is moved from the original “parked” position from DSE, it may result in the wiper blades stopping in the wrong spot on the windshield.



Figure 11 – Attach Pitman Arm to Wiper Linkage

21. Test the wiper system again with the wiper linkage attached to the pitman arm. **NOTE:** You may also want to use tape or zip ties to the splined shaft where the wiper blades attach. This way if there is a problem, the wiper blades won’t hit the cowl and cause any damage to the paint.
22. Upon a successful test, the wiper conversion is now complete. Secure the new wiring harness under the dash and in the engine compartment. Re-install the lower column cover, cowl panel and wiper arms along with any other component that had been removed.

NOTE: In some cases high energy ignition systems have caused interference with the correct operation of the Selecta-Speed Wiper Kit due to spark plug wires routed closely to the wiper motor. If this occurs, re-routing your spark plug wires may be necessary.