



Detroit Speed, Inc.
Front Coilover Conversion
1964-67 GM A-body
P/N: 030306 & 030307

The Detroit Speed, Inc. Front Coilover Conversion Kit is a direct bolt-in kit that provides excellent ride quality along with the adjustability of a coilover. The kit uses an aluminum body coilover shock featuring "Detroit Tuned" valving. All necessary parts are included in the kit.



Item	Description	Quantity
1	DSE "Detroit Tuned" Coilover Shock	2
2	Coilover Spring Adjusting Nut	2
3	5/8" Flat Washer	4
4	Polyurethane Upper Shock Bushing	2
5	Polyurethane Lower Shock Bushing	2
6	Aluminum Spacer	2
7	5/8"-18 Upper Mounting Nylock Nut	1
8	Coilover Spring (550 lb./in or 650 lb./in)	2
9	Thrust Bearing	2
10	Thrust Washer	4
11	3/8"-24 x 1-1/2" Hex Head Bolt	4
12	3/8"-24 Nylock Nut	4
13	3/8" AN Washer	4
14	DSE Spanner Tool	1
15	Instructions	1

Fastener Torque Specifications	
Application	Torque (ft-lbs.)
Coilover Shock Mounting Bolts	35 ft-lbs.
Upper Ball Joint	50 ft-lbs.

1. Chock the rear wheels and loosen the front lug nuts. Raise the front of the vehicle and support the front of the vehicle with jack stands under the frame. Remove the front wheels. Disconnect the front anti-roll bar from the lower control arm.
2. Remove the existing shock from the vehicle. Remove the brake caliper and support it out of the way. Remove the brake rotor.
3. Support the lower control arm with a floor jack and separate the upper ball joint from the spindle. **CAUTION: The coil springs are under tension. The proper spring compressor must be used.** It is not necessary to separate the lower ball joint from the spindle. Remove the factory coil springs.
4. Assemble the coilover shock for installation in the vehicle. The coilover adjuster nut must be threaded all of the way to the bottom of the threads. Install a thrust washer followed by the roller bearing and then another thrust washer. Slide the black flat washer over the threaded portion of the shock along with the lower polyurethane shock bushing [Figure 1].

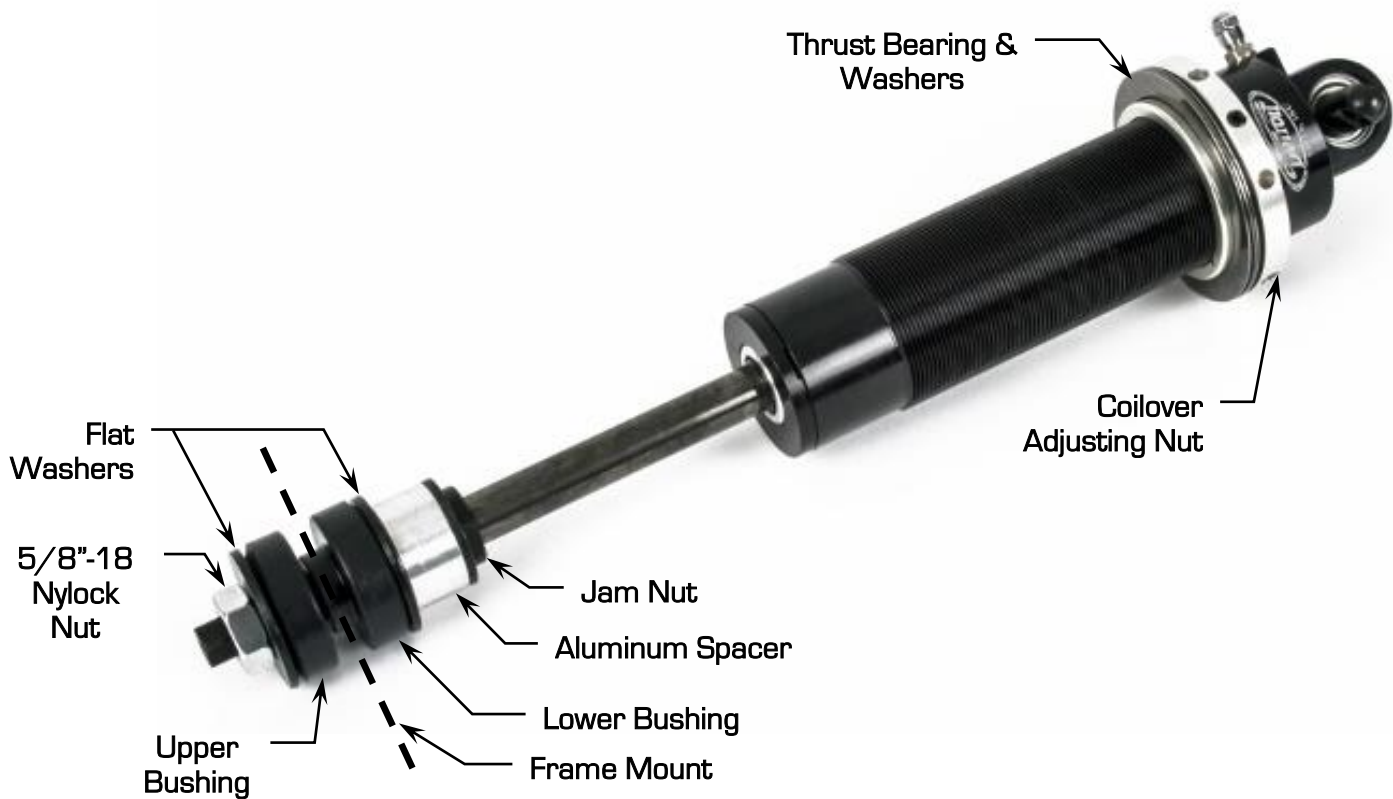

Figure 1 - Shock Assembly

5. Before installation of the coilover shock, the hole size in the frame of the upper coilover shock mount must be opened up to 1" for the lower shock bushings. This can be done using a 1" drill bit or a Uni-Bit. **NOTE:** Use a grinding disc to make sure there are no sharp edges after opening up the upper shock mount hole. Failure to do this would result in the shock bushings to not seat properly [Figure 2 on the next page].



Figure 2 – Remove Sharp Edges/Burrs

6. If using factory or other aftermarket lower control arms, it may be necessary to enlarge the original shock mounting holes in the control arms to $3/8$ " holes.
7. Slide the spring over the coilover shock. Place the shock assembly in the vehicle by angling the shock inward at the top and locating the spring in the upper locating ring in the frame. Turn the spring if necessary to locate the spring into the frame. Make sure the stem of the lower bushing passes through the upper shock mount in the frame (Figure 3).



Figure 3 – Lower Shock Bushing

8. Slide the upper shock bushing over the threaded shaft on the shock followed by a black flat washer. Start the $5/8$ "-18 Nylock Nut a few threads to hold the shock in place. Do not tighten at this time.
9. Insert the provided $3/8$ "-24 x 1- $1/4$ " hex head bolts through the lower shock tie bar. Raise the lower control arm and install the bolts through the lower control arm. **NOTE: The shock tie bar sits on top of the lower control arm.** Thread the $3/8$ "-24 Nylock nuts onto the bolts along with the $3/8$ " AN Washers. Torque the nuts to 35 ft-lbs.
10. Raise the lower control arm and insert the upper ball joint into the spindle. Using the original hardware, install the castle nut onto the upper ball joint and torque to 50 ft-lbs. If necessary, tighten further in order to insert the cotter pin. Make sure to bend the cotter pin after sliding it through the ball joint to insure it does not slide out of the ball joint.

11. Tighten the 5/8"-18 Nylock Nut. To tighten, hold the hex portion of the shaft with a 1/2" box end wrench. **CAUTION:** When tightening the 5/8"-18 Nylock Nut, failure to hold the shaft from turning too many times while under pressure can cause the inner shaft nut to loosen and fall off. This would result in sending the shocks back to be repaired at the customer's expense.
12. Tighten the nut until the upper shock bushing starts to compress and turn the nut one additional turn. **NOTE:** Do not over tighten the Nylock nut.
13. Repeat steps 2-12 for the opposite side of the vehicle.
14. Reinstall the calipers as well as the anti-roll bar. Install the wheels and tires. With the vehicle on the ground, follow step 15 below to adjust the vehicle to the desired ride height.
15. Setting the Vehicle Ride Height

WARNING: DO NOT ADJUST THE COILOVER ADJUSTING NUT WITHOUT THE VEHICLE RAISED OFF THE GROUND TO REMOVE THE WEIGHT OFF THE COILOVER SHOCKS. FAILURE TO FOLLOW THIS PROCEDURE WILL RESULT IN DAMAGED THREADS ON THE SHOCK BODY THAT CANNOT BE WARRANTIED.

- a. With the vehicle assembled with all components installed, adjust the vehicle ride height. Before adjusting the ride height, DSE recommends cleaning the threads of the shock. Once the threads are clean, DSE recommends applying dry bicycle chain lube to the threads of the shock body before adjusting the spanner nut and compressing the coilover spring. Allow the chain lube to dry before adjusting the spanner nut. If you have the non-adjustable shocks, the spanner nut has a soft tip set screw that will need to be tightened before the vehicle is driven.
- b. Detroit Speed does include a spanner tool (P/N: 031060) to adjust ride height however if you have the adjustable coilover shocks, Detroit Speed does offer an adjustment tool available as P/N: 031061 if needed. A photo can be seen in Figure 4.



Figure 4 – Spanner & Adjustment Tool

16. Once the car is adjusted to the desired ride height, have an alignment by a professional alignment shop performed at this point.
17. The installation of the coilover conversion with non-adjustable shocks is now complete.

Non-Adjustable Shocks



Figure 5 - DSE Non-Adjustable Shock

18. If the Single Adjustable, Double Adjustable or the Double Adjustable Remote Canister Coilovers were purchased as an upgrade, refer to the following information for adjustment procedures.

DSE Single Adjustable Shocks

To change from the recommended “Detroit Tuned” valving, adjustments can be made independently to the rebound setting. The rebound is controlled by the sweeper at the upper shock mount (Shock is mounted body side down). The sweeper rotates clockwise (+) to increase the damping and counterclockwise (-) to decrease the damping. Refer to Figure 6a.



Figure 6a - DSE Single Adjustable Shock

To return to the DSE recommended settings, turn the sweeper clockwise (+) to full damping. Once at full damping, turn counterclockwise (-) to reach the recommended settings. Refer to Figure 6b for the rebound settings.

Rebound (Sweeper)..... 15 Sweeps (counterclockwise, -)

Figure 6b - DSE Recommended Settings

Adjuster Operation

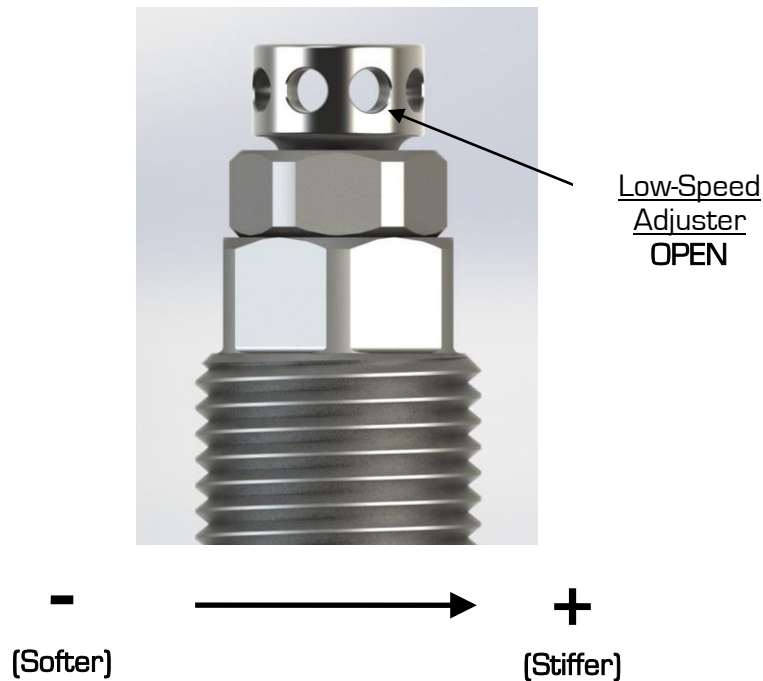

- **Adjuster (60-64 Sweeps)**

The low-speed adjuster is a “clicker” style adjuster meaning that its adjustment is measured by detents located inside the sweeper. There are 16 sweeps per 1 revolution of the sweeper. It uses a right-hand thread in its operation which means as you increase low-speed, the adjuster will move up on the eyelet. The recommended change for an adjustment is 8 sweeps at a time. The low-speed adjuster’s reference position is **full stiff** (closed, or all the way up) and referred to -0 (-0 = full stiff, -64 = full soft).

- **Tuning Notes**

- **Racetrack**

- For more grip, soften the damping.
- For increased platform control, stiffen the damping.

- **Street**

- For a more comfortable ride, soften the damping

DSE Double Adjustable Shocks

To change from the recommended “Detroit Tuned” valving, adjustments can be made independently to both the high and low speed settings. The rebound is controlled by the sweepers at the upper shock mount. The sweepers rotate clockwise (+) to increase the damping and counterclockwise (-) to decrease the damping. The sweepers can be seen in Figure 7a on the next page.



Figure 7a - DSE Double Adjustable Shock

When adjusting the low speed rebound start at full (+) position, when adjusting the high speed rebound start at full (-) position. To return to the DSE recommended settings turn the sweeper clockwise(+) to full damping for the low speed setting, and counterclockwise (-) to full damping for the high speed setting. Once at full damping, turn counterclockwise (-) for the low speed setting, and clockwise (+) for the high speed setting to reach the recommended settings. Refer to Figure 7b for recommended settings.

- Low Speed Rebound [Sweeper]..... 15 sweeps [counterclockwise](-)
- High Speed Rebound [Sweeper]..... 4 sweeps [clockwise](+)

Figure 7b - DSE Recommended Settings

DSE Double Adjustable Shocks w/Remote Canisters

To change from the recommended "Detroit Tuned" valving, adjustments can be made independently to both the high and low speed settings. The rebound is controlled by the sweepers at the upper shock mount. The sweepers rotate clockwise (+) to increase the damping and counterclockwise (-) to decrease the damping. Refer to Figure 8a on the next page.

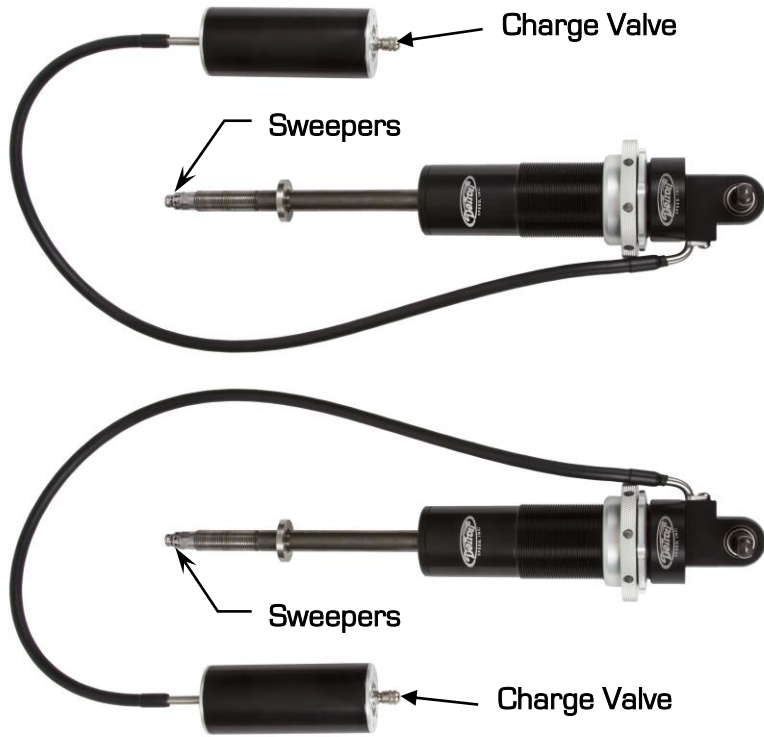

Figure 8a - DSE Double Adjustable Shock w/Remote Canister

When adjusting the low speed rebound start at full (+) position, when adjusting the high speed rebound start at full (-) position. To return to the DSE recommended settings turn the sweeper clockwise (+) to full damping for the low speed setting, and counterclockwise (-) to full damping for the high speed setting. Once at full damping, turn counterclockwise (-) for the low speed setting, and clockwise (+) for the high speed setting to reach the recommended settings. Refer to Figure 8b for recommended settings.

- Low Speed Rebound [Sweeper]..... 15 sweeps [counterclockwise](-)
- High Speed Rebound [Sweeper]..... 4 sweeps [clockwise](+)

Figure 8b - Recommended Settings for DSE Double Adjustable Shocks

Adjuster Operation

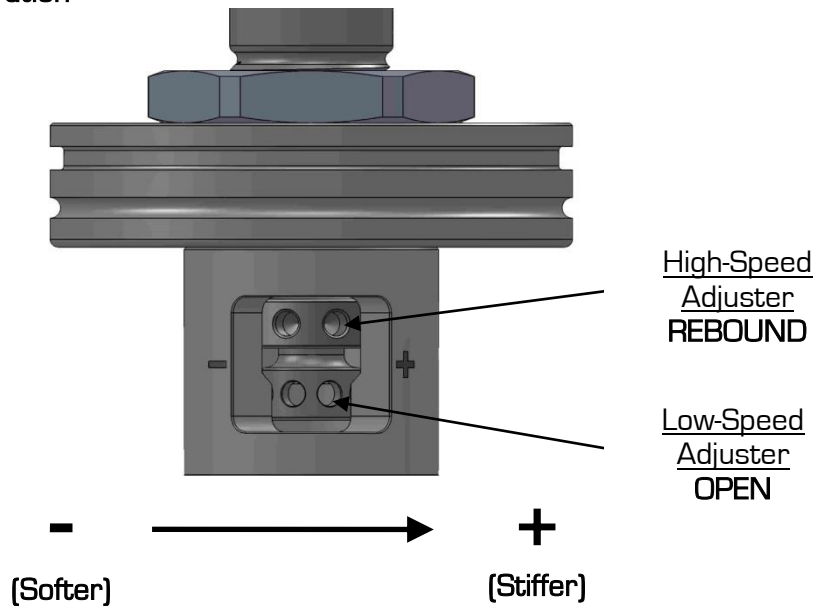

- **High-Speed Adjuster (12 Sweeps)**

The high-speed adjuster is a “sweep” style adjuster meaning that its adjustment is measured by the location of the adjuster in the eyelet window. It uses a left-hand thread in its operation which means; as you increase high-speed, the adjuster will move down in the window*. The high-speed adjuster’s reference position is **full soft** and referred to as +0 (+0 = full soft, +12 = full stiff).

- **Low-Speed Adjuster (25 Sweeps)**

The low-speed adjuster is a “clicker” style adjuster meaning that its adjustment is measured by detent grooves located inside the high-speed shaft. It uses a right-hand thread in its operation which means; as you increase low-speed, the adjuster will move up in the window. The low-speed adjuster’s reference position is **full stiff** and referred to -0 (-0 = full stiff, -25 = full soft).

**The low-speed adjustment does not change when adjusting the high-speed.*

To aid in the installation of the reservoirs, we also offer a set of Billet Aluminum Remote Canister Mounts. The canister mounts are available exclusively through DSE, P/N: 032102. They are shown in Figure 9.



Figure 9 – Billet Aluminum Remote Canister Mounts

Legal Disclaimer: *Detroit Speed, Inc. is not liable for personal, property, legal, or financial damages from the use or misuse of any product we sell. The purchaser is solely responsible for the safety and performance of these products. No warranty is expressed or implied.*