



INSTALLATION INSTRUCTIONS

POWER STEERING COOLER KIT

PART # 13200, 13210, 13211, 13212 & 13213

Please read these instructions completely before starting the installation.

KIT CONTENTS

| QTY. | DESCRIPTION | QTY. | DESCRIPTION |
|------|----------------------|------|----------------|
| 1 | Oil Cooler | 2 | Mounting Rods |
| 4ft. | 11/32" OEM Spec Hose | 2 | Mounting Clips |
| 4 | Hose Clamps | 2 | 1x1 Foam Pads |

TOOLS NEEDED

Standard Screw Driver
or 5/16" Nut Driver
Dyke Pliers
Razor Knife

IMPORTANT

This cooler is designed to install on the Low Pressure side of the pump. Do not cut or remove the High Pressure hose.

COOLER LOCATION

When selecting the best location for your vehicle, always consider a location that will deliver the maximum airflow.

The Power Steering Cooler can be mounted in multiple locations on your vehicle. Reference Diagram # 1 for possible cooler positions. #1 is the ideal location, #2 is second best and #4 being the last choice.

Note: The Cooler core will flow in either direction, there is no specified inlet or outlet port.

Diagram #1

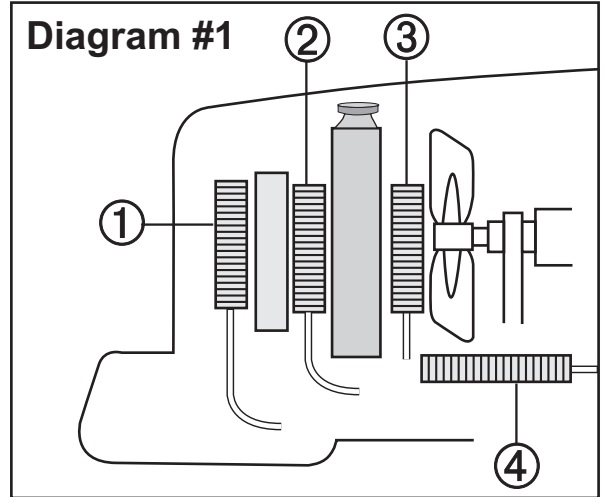

PRE-INSTALLATION

1. Identify the 11/32" X 4' Hose and Hose Clamps.
2. Slide one hose clamp on each end of the supplied Hose.
3. Using a dab of oil, lubricate each end of the hose and install hose onto the cooler inlets forming a loop.
4. Secure in place using the Hose Clamps. (See Diagram #2)

COOLER INSTALLATION

Mounting

(See Diagram #2)

1. Identify the 2 Mounting Rods, 2 Mounting Clips and 2 1x1 Foam Pads.
2. Install the 2 Mounting Rods thru the Oil Cooler.
3. Take the 1x1 Foam Pads supplied, peel off the paper lining & slide them onto the Mounting Rods, sticking them against the Cooler.
4. Take the Cooler Assembly with attached looped hose and hold in the desired location.
5. Install the 2 Mounting Rods thru the Radiator/Condenser core.

Warning: Do not use excessive force when pushing the Mounting Rods through the Radiator/Condenser. Excessive force could cause damage to the fins and possibly puncture a tube.

6. Take the Mounting Clips supplied, making sure they are in the correct direction (Derales writing out) install onto the Mounting Rods and cinch them until the 1x1 Foam Pads are slightly compressed.
7. Cut off any excess Mounting Rods.

Diagram #2

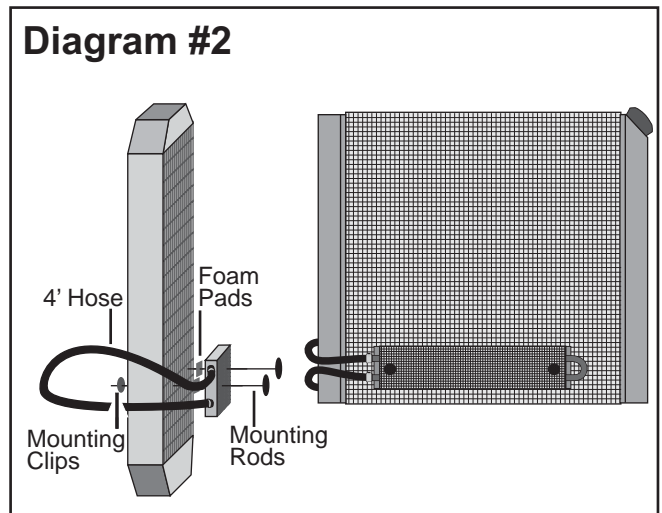

ROUTING HOSES

This cooler is designed to install on the Low Pressure side of the power steering pump. (See Diagram #3)

1. Identify the Low Pressure hose coming from the power steering pump. The Low Pressure hose is usually smaller and is secured by a hose/band clamp. The High Pressure hose is usually larger and has swaged fittings.
2. Disconnect the Low Pressure hose from the power steering pump.
3. Carefully route the looped hose now attached to the cooler toward the power steering pump.

Note: The Oil Cooler will flow in either direction, there is no specified inlet or outlet port.

4. Using the Hose Clamp supplied, cut hose to length and attach hose coming from the Oil Cooler to the fitting on the power steering pump.
5. Route remaining hose toward the steering box.
6. Using the Hose Clamp supplied, cut hose to length and attach remaining hose coming from the Oil Cooler to the fitting on the steering box.

Warning: When routing hoses, be sure to keep all hoses away from sharp edges, moving parts and hot engine components. Hoses should be routed carefully and should not be bent in less than a 3" radius.

Important: A kinked hose will restrict flow and could cause pump failure.

Diagram #3

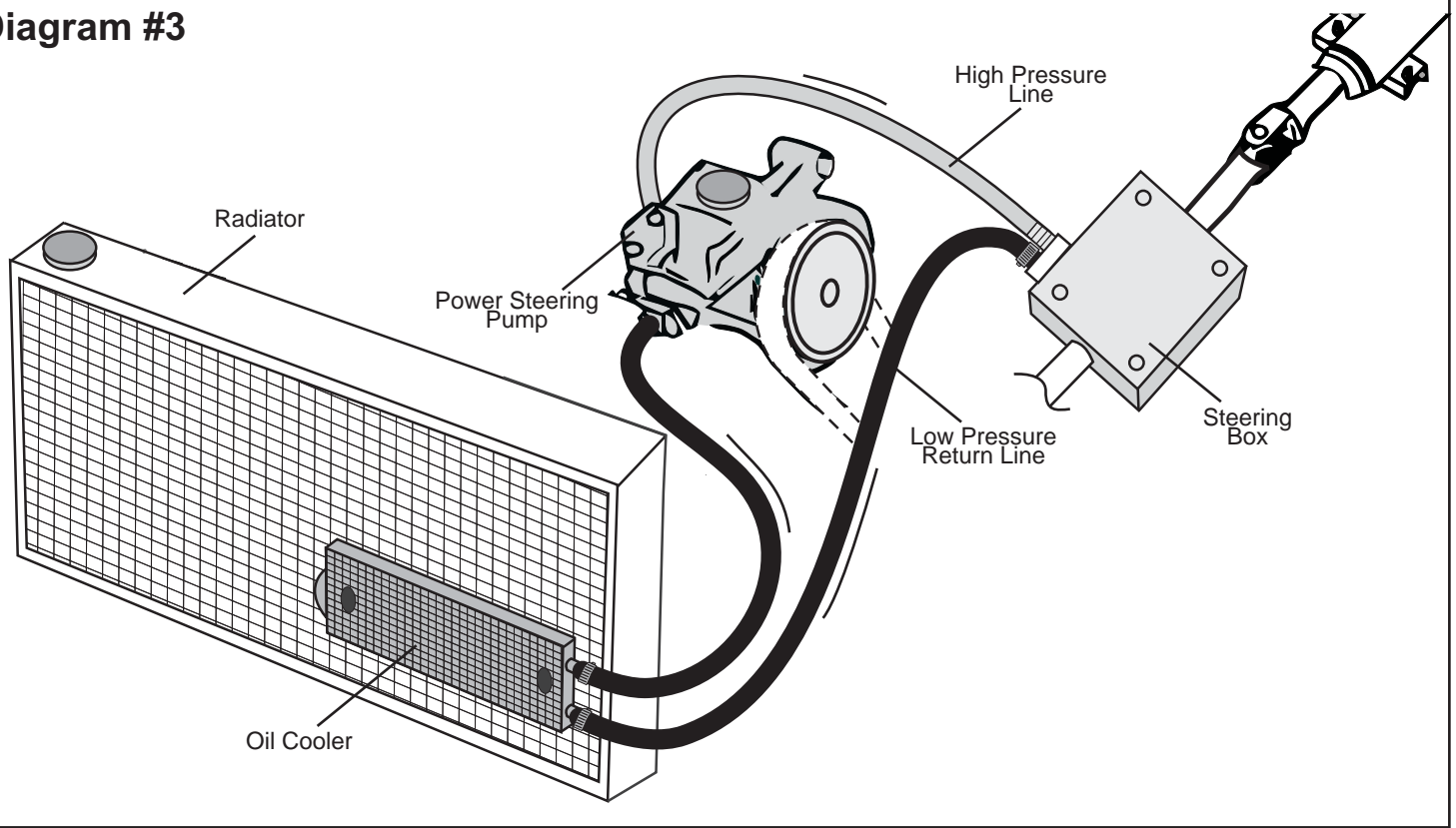

SYSTEM CHECK

1. Check fluid level and add fluid as needed.
2. Start vehicle, with the parking brake applied slowly rotate the steering wheel from left to right several times. This will bleed the system.
3. Turn off engine and check all connections for leaks.
4. Re-check fluid level and add fluid as needed.

(Page 2)

Warning: Installation of accessories should only be undertaken by those with mechanical knowledge and are familiar with working on vehicles. Always use eye protection (goggles, safety glasses or shield). Park the vehicle in a well lit area, on level ground and apply the parking brake. Only work on a cold vehicle that has been sitting overnight, failure to do so will result in severe burns and injury. Before starting the vehicle, make sure no tools or any other items are left under hood that could interfere with or be drawn into moving parts of the engine. Failure to follow instructions can lead to severe damage and personal injury.