



INSTALLATION INSTRUCTIONS ENGINE OIL COOLER KIT PART # 15451

Please read these instructions completely before starting the installation.

KIT CONTENTS

QTY.	DESCRIPTION	QTY.	DESCRIPTION
1	Oil Cooler	1	3/4-16 Hex Sleeve Nut
1	Spin-On Adapter	1	13/16-16 Hex Sleeve Nut
1	Adapter Plate	1	18mm x 1.5 Hex Sleeve Nut
1	Ports Up Filter Mount	1	20mm x 1.5 Hex Sleeve Nut
1	O-ring (Spin-On Adapter)	1	22mm x 1.5 Hex Sleeve Nut
1	O-ring (Adapter Plate)	10ft	1/2" OEM Spec Hose
1	Snap Ring	5	6" Zip Ties
1	3/4-16 Filter Nipple	8	Hose Clamps
6	1/2" NPT x 1/2" Hose Barb	4	Mounting Rods
3	#14 Sheet Metal Screws	4	Foam Pads
		4	Mounting Clips

TOOLS NEEDED

Standard Screw Driver or 5/16" Nut Driver	7/8" Open End Wrench
Dyke Pliers	11/16" Open End Wrench
Drill and 3/16" Bit	1 1/8" Socket
	Thread Sealant Tape

IMPORTANT

This kit is designed to fit vehicles with engine block oil filter landings ranging from 2 1/2" to 3 1/2", which represents 90% of all vehicles.

COOLER LOCATION

When selecting the best location for your vehicle, always consider a location that will deliver the maximum airflow.

The Oil Cooler can be mounted in multiple locations on your vehicle. Reference Diagram # 1 for possible cooler positions. #1 is the ideal location, #2 is second best and #4 being the last choice.

Note: The Cooler core will flow in either direction, there is no specified inlet or outlet port.

PRE-INSTALLATION

1. Identify the 1/2" NPT x 1/2" Barb Fittings.
2. Using Thread Sealant Tape or suitable sealant, install the two 1/2" NPT x 1/2" Barb Fittings onto the Oil Cooler, two 1/2" NPT x 1/2" Barb Fittings onto the Spin-On adapter, and two 1/2" NPT x 1/2" Barb Fittings onto the Ports Up filter mount.
3. Identify the 1/2" x 10ft. OEM Spec Hose and Hose Clamps.
4. Slide one hose clamp on each end of the supplied Hose.
5. Using a dab of oil lubricate each end of the hose and install hose onto the 1/2" barb fittings now installed on the cooler forming a loop.
6. Secure in place using the Hose Clamps. (See Diagram #2)

Diagram #1

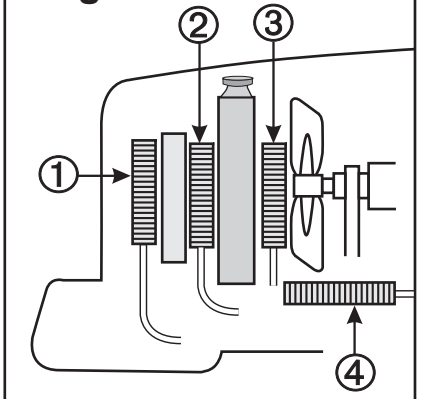

COOLER MOUNTING

(See Diagram #2)

1. Identify the 4 Mounting Rods, 4 Mounting Clips and 4 1x1 Foam Pads.
2. One by one, Install the 4 Mounting Rods thru the Oil Cooler.
3. Take the 1x1 Foam Pads supplied, peel off the paper lining and slide them onto the Mounting Rods, sticking them against the Oil Cooler.
4. Take the Cooler Assembly with attached looped hose and hold in the desired location.
5. Install the 4 Mounting Rods thru the Radiator/Condenser core.

Warning: Do not use excessive force when pushing the Mounting Rods through the Radiator/Condenser. Excessive force could cause damage to the fins and possibly puncture a tube.

6. Take the Mounting Clips supplied, making sure they are in the correct direction (Dera Performance writing out) install onto the Mounting Rods and cinch them until the 1x1 Foam Pads are slightly compressed.
7. Cut off any excess Mounting Rods.

Diagram #2

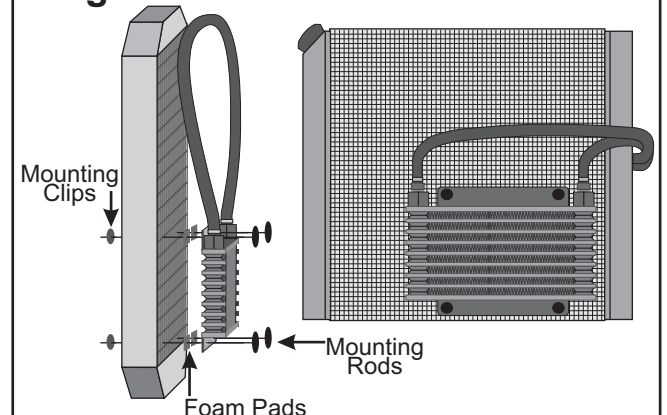

Important: The Adapter Plate & O-ring are designed to fit vehicles with a 3 1/2" filter landing. Primarily 1963-2007 GM SB & BB V-8 engines.

There are 5 supplied Sleeve Nuts in this kit. Only 1 Sleeve Nut will be used for your application.

SELECTING COMPONENTS

To easily select the correct components for your application, follow the steps below. Then proceed to the INSTALLATION section.

Selecting the Spin-on Adapter and/or Adapter Plate

1. Remove the factory oil filter from the vehicle.
2. Using a rag, clean the oil filter landing on the engine.
3. Take the supplied Spin-on Adapter and Adapter Plate.
4. To determine if your application uses the supplied Adapter Plate, first hold the Adapter Plate up to the oil filter landing on the engine block. The casting needs to seat directly onto the landing without obstruction. If the Adapter Plate is too large, then disregard the Adapter Plate and O-ring. (See Diagram #4)
5. Take the supplied Spin-On Adapter and hold it up the oil filter landing on the engine block. The casting needs to seat directly onto the landing without obstruction.

Selecting the Sleeve Nut

1. Take the 5 supplied Sleeve Nuts, try and screw each Sleeve Nut onto the filter nipple on the engine block until the correct size will completely thread onto the nipple. Once you have located the correct Sleeve Nut, disregard the remaining 4 Sleeve Nuts.
2. Take the Sleeve Nut and slide it into the Spin-on Adapters hex feature. Sleeve Nut will only install correctly in one direction. (See Diagram #3)
3. Take the supplied Snap Ring and carefully install into the snap ring groove of the casting making sure it is securely fastened. (See Diagram #3)

Warning: It is recommended that you wear the proper eye protection when installing Snap Ring.

Diagram #3

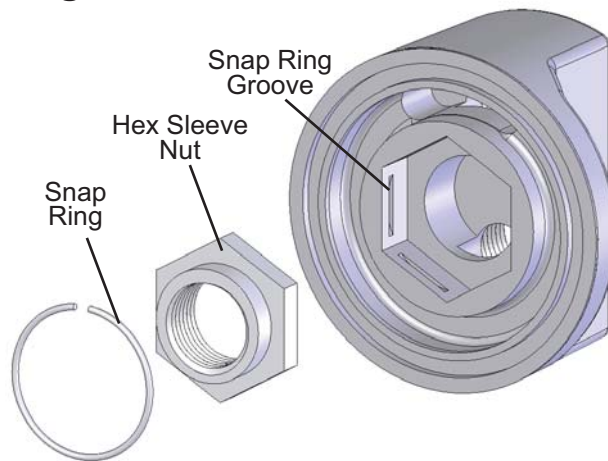
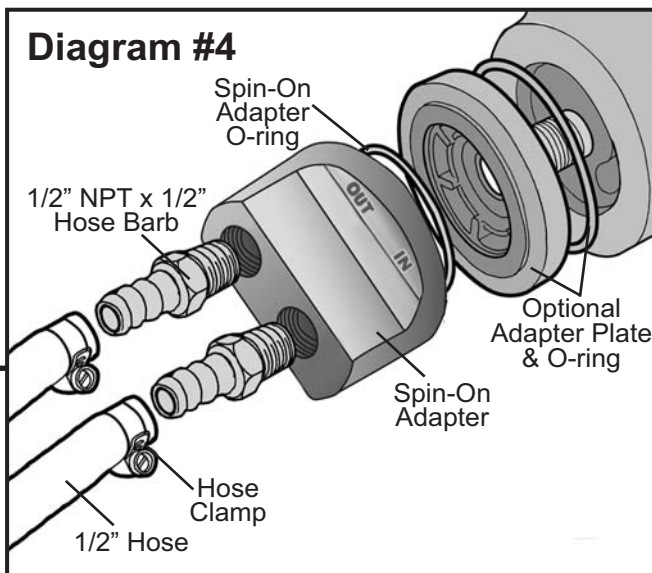

Diagram #4



SPIN-ON ADAPTER INSTALLATION

1. Apply a light coat of oil onto the O-ring(s).
2. Take the O-ring and install into the groove on the Spin-On Adapter and Adapter Plate (if used).
3. Install onto the engine. (See Diagram #4)
4. Hand Tighten with the same force used in tightening a factory oil filter.

FILTER MOUNT INSTALLATION

1. Choose a convenient location for the Ports-Up Filter Mount. Make sure there is enough space for future servicing of the oil filter. Suggested Locations: Firewall, Radiator Support, Fender well.
2. Take the 3/4-16 Filter Nipple supplied, making sure the shorter end of threads is installed onto the Ports-Up Filter Mount. (See Diagram #5)
3. Using the filter mount as a template, mark and drill three 3/16" holes.
4. Using the #14 Sheet Metal Screws provided, install the Ports-Up Filter Mount onto the vehicle.

Important: The new Filter Mount is designed to accept a 3/4-16 oil filter. Use Derale Part # 13092 or reference chart below for manufacturers part numbers.

OIL FILTER CHART	
BRAND	PART #
AC	PF2
Fram	PH8A
Motorcraft	FL1A
Purolator	PER1A

Diagram #5

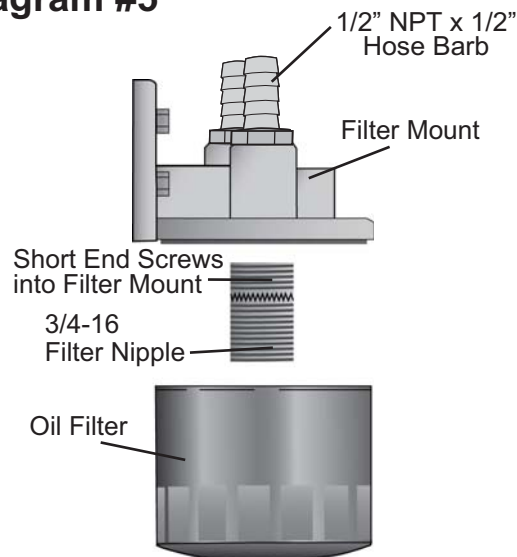

ROUTING HOSES

Note: The Cooler core will flow in either direction; there is no specified inlet or outlet port.

Important: The oil flow direction should go in the following order: Engine, Ports Up Filter Mount, Oil Cooler, and then back to the Engine. (See Diagram #6)

1. Using the remaining four Hose Clamps supplied, route the looped hose from the Oil Cooler along the frame toward the Ports Up Filter Mount and/or the Spin-on Adapter.

Note: When routing hoses, be sure to keep all hoses away from sharp edges, moving parts and hot engine components. Hoses should be routed carefully and should not be bent in less than a 5" radius.

2. Attach either hose coming from the Oil Cooler to the "OUT" port on the Ports Up Filter Mount.
3. Attach the remaining hose on the Oil Cooler to the "IN" port on the Spin-on Adapter.
4. Attach a hose from the "OUT" port on the Spin-on Adapter to the "IN" port on the Ports Up Filter Mount.
5. Apply a light coat of oil onto the O-ring of your new oil filter and install on the Ports Up Filter Mount.

Diagram #6

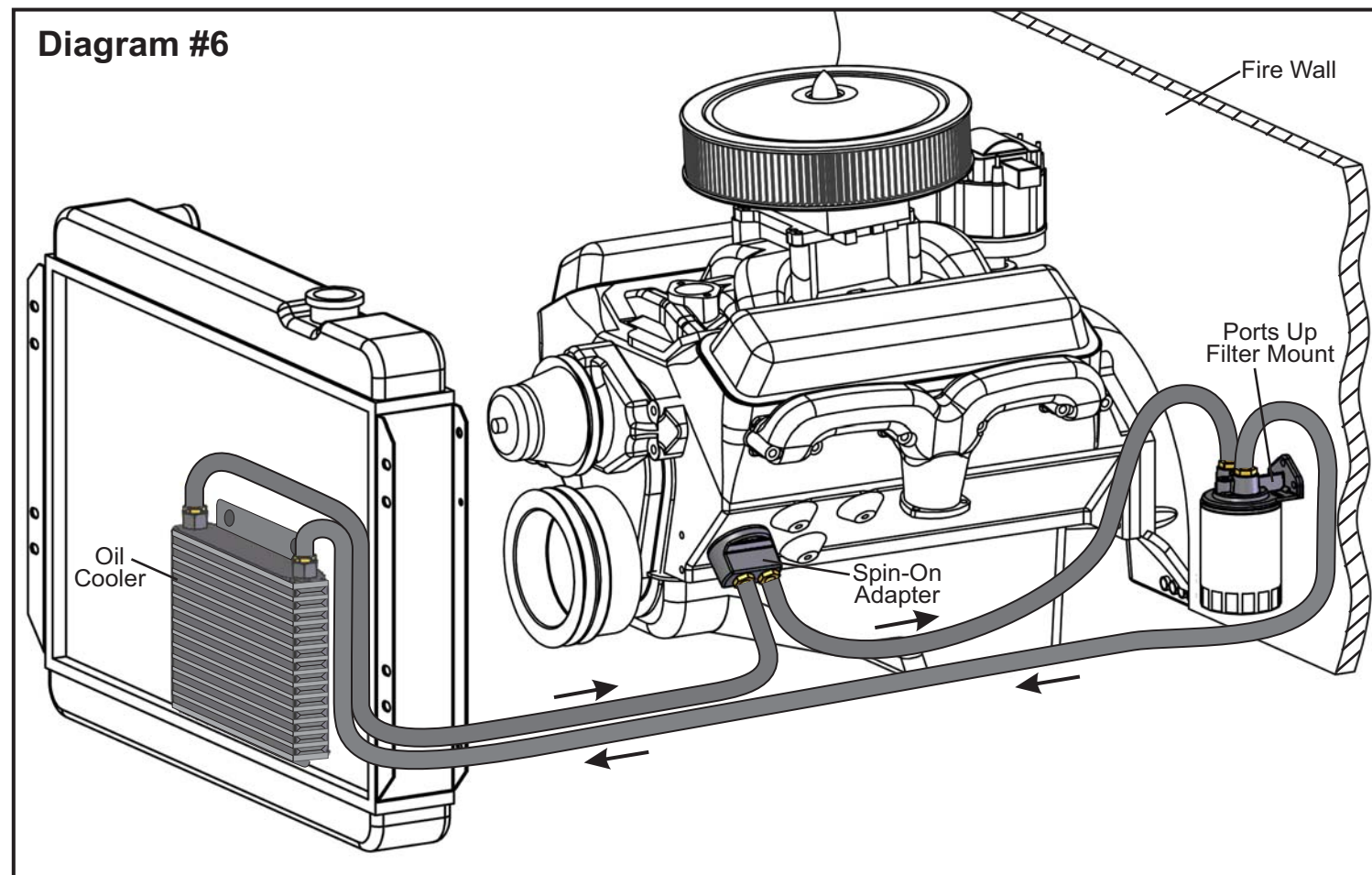

VEHICLE TESTING

1. Start the engine and quickly check all connections for leaks.
2. Turn-off the engine and check oil level.
3. Add oil as needed.

(Page 3)

Warning: Installation of accessories should only be undertaken by those with mechanical knowledge and are familiar with working on vehicles. Always use eye protection (goggles, safety glasses or shield). Park the vehicle in a well lit area, on level ground and apply the parking brake. Only work on a cold vehicle that has been sitting overnight, failure to do so will result in severe burns and injury. Before starting the vehicle, make sure no tools or any other items are left under hood that could interfere with or be drawn into moving parts of the engine. Failure to follow instructions can lead to severe damage and personal injury.