



INSTALLATION INSTRUCTIONS IN-LINE FAN THERMAL SWITCH PART # 35030

Please read these instructions completely before beginning installation

KIT CONTENTS

QTY.	DESCRIPTION
1	Thermal Switch
1	Adapter Fitting

IMPORTANT

The in-line thermal switch is designed to thermostatically control an electric fan up to 10 amps. In the case of fan(s) that draw more than 10 amps a relay must be used.

Diagram #1

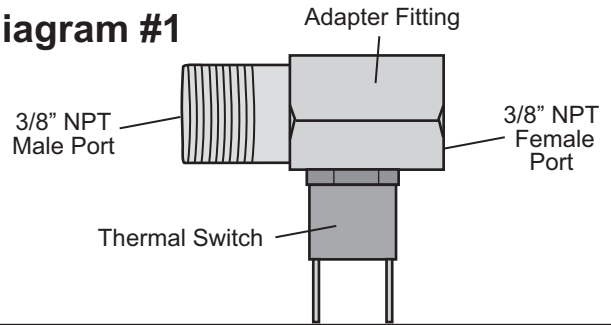

THERMAL SWITCH INSTALLATION

1. Locate the factory engine temperature sensor right next to the upper radiator hose on the front of the engine. (See Diagram #2)
2. Carefully disconnect the factory temperature sensor wire plug.
3. Temporarily remove the factory temperature sensor turning it counter clockwise.
4. Clean old thread sealant on factory temperature sensor.
5. Locate the supplied 3/8" NPT Aluminum Adapter. Using thread sealant tape, install the MALE end of the 3/8" NPT Adapter into the vehicles 3/8" port. (See Diagram # 2)
6. Take the factory temperature sensor. Using Thread Sealant Tape, install the factory temperature sensor into the the 3/8" NPT Aluminum Adapter.

Warning: The supplied Thermal Switch and 3/8" NPT Aluminum Adapter unit are preassembled at factory using thread locker. Do not attempt to adjust, tighten or loosen the Thermal Switch. Tampering with this assembly will void factory warranty.

Diagram #2

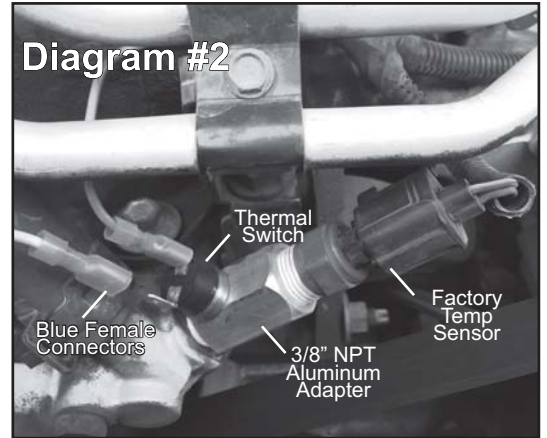

For illustrative purposes only.

WIRING

Note: Optional relay and harness not included

Using the Convolved Tubing, 4" Zip Ties, extra Wire and Electrical Connectors supplied, follow the instructions below. (See Diagram #3)

Warning: When extending wires, always use the identical gauge wire as provided.

ELECTRIC FAN

BLACK Wire: Attach the Black wire to a good Chassis Ground (-).

RED Wire: Attach the Red wire to the Orange wire on the Optional Relay Wire Harness.

THERMAL SWITCH

Note: Wires running to the Thermal Switch can be routed through the plastic factory wire runner on the top of the engine.

To open: There are several plastic clips on each side of the wire runner. Using a small screw driver, carefully release each clip. Be careful not to break clips!

1. Attach EITHER terminal on the Thermostat Switch to the Optional Yellow wire coming from the Relay Wire Harness.
2. Attach a 12 volt switched ignition source to the remaining terminal on the Thermal Switch.

Warning: If this wire is connected to a constant power source (battery) the electric fan will run after the vehicle has been shut off and could ultimately affect battery performance.

Diagram #3

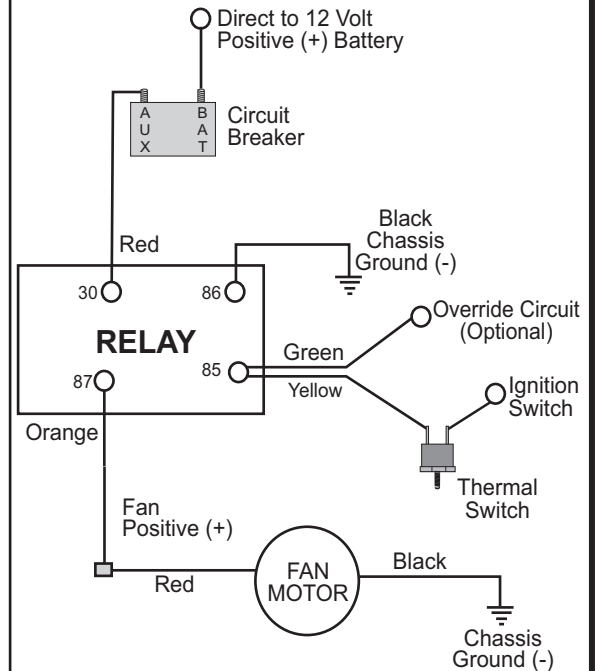

Relay in illustration is Optional and not included

Warning: Installation of accessories should only be undertaken by those with mechanical knowledge and are familiar with working on vehicles. Always use eye protection (goggles, safety glasses or shield). Park the vehicle in a well lit area, on level ground and apply the parking brake. Only work on a cold vehicle that has been sitting overnight, failure to do so will result in severe burns and injury. Before starting the vehicle, make sure no tools or any other items are left under hood that could interfere with or be drawn into moving parts of the engine. Failure to follow instructions can lead to severe damage and personal injury.