



INSTALLATION INSTRUCTIONS HIGH OUTPUT SINGLE RAD FAN PART # 16925

Please read these instructions completely before beginning installation

KIT CONTENTS

QTY.	DESCRIPTION	QTY.	DESCRIPTION
1	Fan Shroud Assembly	4	Mounting Clips
4	Mounting Rods	4	1x1 Foam Pads
4	Rubber Isolators		

TOOLS NEEDED

Dyke Pliers
 5/16" Open End Wrench
 Standard Screw Driver or
 5/16" Nut Driver
 Drill
 5/32" Drill Bit
 12V Test Light
 Wire Stripper
 Crimping Tool

Diagram #1

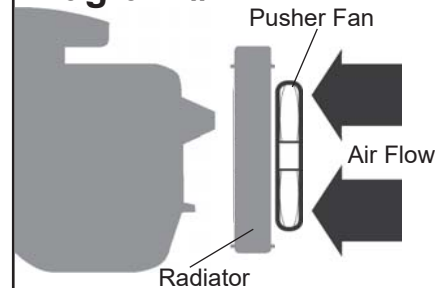

IMPORTANT

This fan assembly is designed for PUSHER APPLICATIONS.

Note: Replacement fan for M13 & A13 Derale shrouded fans.

MOUNTING

1. Position the Electric Fan in the desired location. Note the location and remove fan.
2. Take the four Rubber Isolators and four Mounting Rods supplied. Using one Mounting Rod at a time, install the Mounting Rod through the Electric Fan, then through the Rubber Isolator and finally through the Radiator Core. (See Diagram #2)

Caution: Do not use excessive force when pushing Mounting Rods through radiator core. Excessive force could cause damage to the radiator fins and/or core. Plastic Rods should not be inserted thru both the radiator and the condenser cores.

3. Take the 1 x 1 Foam Pads provided and install them onto the Plastic Rods now protruding through the radiator core. (See Diagram #2)
4. Take the Mounting Clips provided, making sure they are in the correct direction (Deralé writing out) install onto the Plastic Rods and cinch them until the 1 x 1 Foam Pads are compressed. (See Diagram #2)
5. Cut off the excess Mounting Rods.

Diagram #2

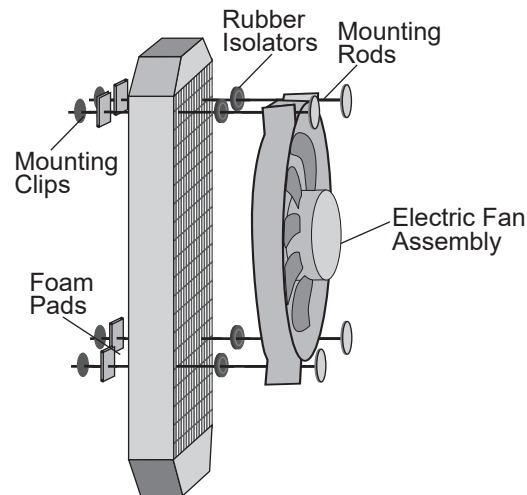
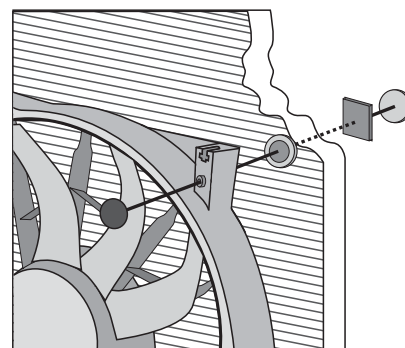

RELAY WIRE HARNESS MOUNTING (NOT SUPPLIED)

1. Taking into consideration fan placement & wire routing requirements, choose a convenient location. Avoid mounting near HOT engine components.
2. Using the relay bracket as a template, mark and drill a 5/32" hole in the proper location.
3. Using a #10 Sheet Metal Screw, install the relay/wire harness. (See Diagram #3)

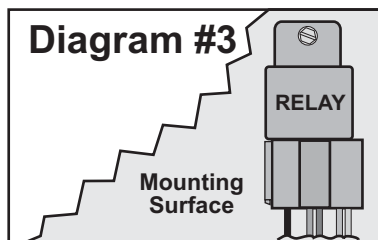

WIRING

TIPS

Always disconnect vehicles battery before beginning installation involving your vehicles electrical system.
 All 12 Volt Positive leads require the use of the appropriate fuse load rating to avoid damage to your vehicles electrical system.
 Always insist on using only high quality components (wire, connectors, and switch) for use in installation of your new Derale Electric Fan Assembly.

(Continues on reverse side)

WIRING OPTIONS

* Switched - Utilizing an automotive rated thermostat or manual switch

There are a few options on how to activate (turn on) your new Electric Fan Assembly.

1. Manual Switch - Install a switch in the passenger compartment and turn on Electric Fan as desired.
2. Electric Fan Thermostat Switch
 - A. Adjustable Thermostat - Allows an adjustment range for you to determine optimal turn on temperature.
 - B. Pre Determined Temperature - Thermostat has a pre determined temp. from the factory that determines turn on temp.

Important: When purchasing a thermostat always consider the maximum amp draw. Some thermostats are not designed to properly handle 25 amps.

Note: When installing the Electric Fan with a Thermostat always follow manufacturer's instructions for specific details.

WIRING INSTALLATION USING RELAY(S) (NOT SUPPLIED)

RED Wire - Attach to the Positive side of Battery (+)

BLACK Wire - Attach to a good Chassis ground (-)

ORANGE Wire - Attach to the Red Positive Electric Fan Lead (Fan +)

YELLOW Wire - Attach to (+) 12V Switched Power (Thermostat or Manual Switch)

GREEN Wire* - (OPTIONAL) Attach to the Positive feed from the A/C Clutch

*This wire will allow you to turn on the Electric Fan every time the vehicles air conditioning is turned on. If you do not wish to use this option, please disregard the Green wire.

ELECTRIC FAN

BROWN Wire - (+) Positive Fan lead Attach to the ORANGE wire coming from the relay harness

BLACK Wire - (-) Negative Fan Lead Attach to a good Chassis ground (See Diagram #4)

Diagram #4

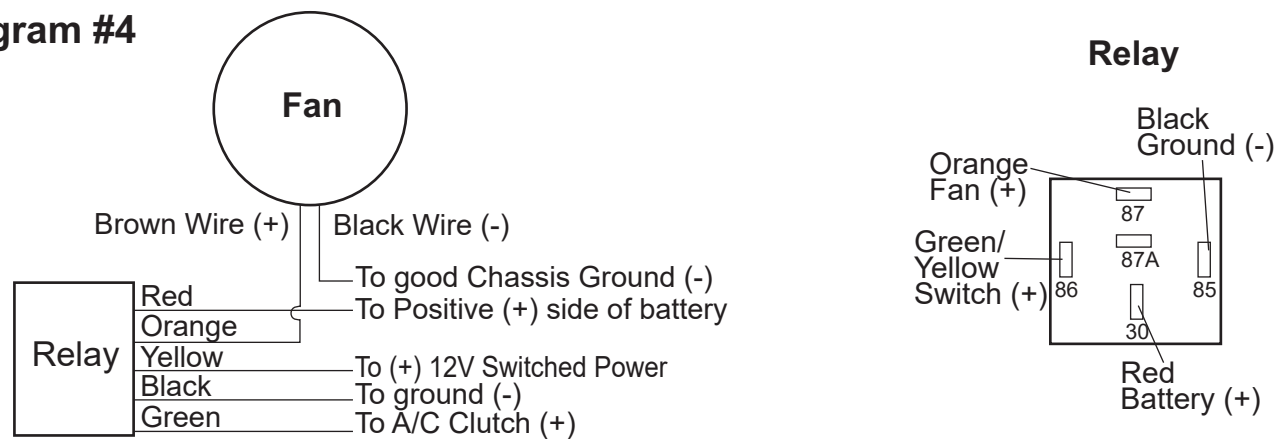

TROUBLESHOOTING Q&A

Q: Why is the fan(s) blowing in the wrong direction?

A: Switch the Positive (+) and Negative (-) fan leads. This will reverse the airflow direction.

Q: Why doesn't the fan(s) turn on?

A: 1. Check all connections to make sure all contacts are crimped correctly.
2. Check all Ground (-) connections to make sure all paint is sanded off and you are getting a metal to metal contact.

Q: I have checked all connections and fan still will not turn on?

A: Take the GREEN wire and temporarily attach it to the positive side of the battery. This should activate the fan. If the fan comes on there most likely is a problem with the connection on the YELLOW wire/Manual Switch/Thermostat. If the fan does not come on remove relay and reinstall making sure it is seated correctly.

Warning: Installation of accessories should only be undertaken by those with mechanical knowledge and are familiar with working on vehicles. Always use eye protection (goggles, safety glasses or shield). Park the vehicle in a well lit area, on level ground and apply the parking brake. Only work on a cold vehicle that has been sitting overnight, failure to do so will result in severe burns and injury. Before starting the vehicle, make sure no tools or any other items are left under hood that could interfere with or be drawn into moving parts of the engine. Failure to follow instructions can lead to severe damage and personal injury.