



INSTALLATION INSTRUCTIONS ADJUSTABLE SINGLE ELECTRIC FAN CONTROLLER PART # 16779

Please read these instructions completely before beginning installation

KIT CONTENTS

QTY.	DESCRIPTION	QTY.	DESCRIPTION
1	Adjustable Fan Controller with 3/8" NPT Thread-in Probe	3	Yellow Butt Connector
1	25 Amp Circuit Breaker	2	Yellow #10 Ring Terminal
1	6ft 10 Ga. Red Wire	1	Yellow 5/16" Ring Terminal
6	#10 Sheet Metal Screw	2	Blue Wire Tap Connector
		4	4" Wire Ties
		1	Red #10 Ring Terminal

TOOLS NEEDED

Drill	Standard Screw Driver (1/8" wide blade)
5/32" Drill Bit	Wire Stripper
Teflon Tape	Wire Crimping Tool
12V Test Light	3/4" Open End Wrench or a 5/16" Nut Driver

IMPORTANT

This unit utilizes an auto resetting circuit breaker to protect the fan and controller circuit. In the event of an electrical short, the breaker will "trip" and open the connection between the battery and the controller. If this happens, turn the vehicle off and let it cool before restarting the system. The breaker will automatically reset.

WARNING

This unit is designed to control one electric fan with a **Maximum Draw of 35 Continuous Amps.**

For proper installation the control module must be mounted within 5 feet of the vehicle's battery.

CONTROL MODULE INSTALLATION

1. Choose a convenient location, preferably along the vehicles core support near the battery. Take in to consideration probe placement & wire routing requirements. Avoid mounting near HOT engine components or a location that would be in direct contact with any road debris.

2. Using the module as a template, mark and drill four 5/32" holes in the proper location.

3. Using four #10 sheet metal screws supplied, secure the unit in place.

CIRCUIT BREAKER MOUNTING

1. Choose a convenient location for the Circuit Breaker that is between the Fan Controller and the Battery.

2. Using the breaker as a template, mark and drill two 5/32" holes in the proper locations.

3. Using the remaining two #10 sheet metal screws supplied, secure the Circuit Breaker in place.

THERMOSTAT PROBE INSTALLATION (See Diagram #2)

Placement

1. Locate a 3/8" NPT water jacket port either on the radiator, waterneck, intake manifold or cylinder heads.

Installation

1. Using Thread Sealant Tape, thread the 3/8" NPT probe into the desired port. Be careful not to over tighten.

Note: Probe wires can be lengthened if necessary. When lengthening wires always use good quality wire & connections to assure proper function.

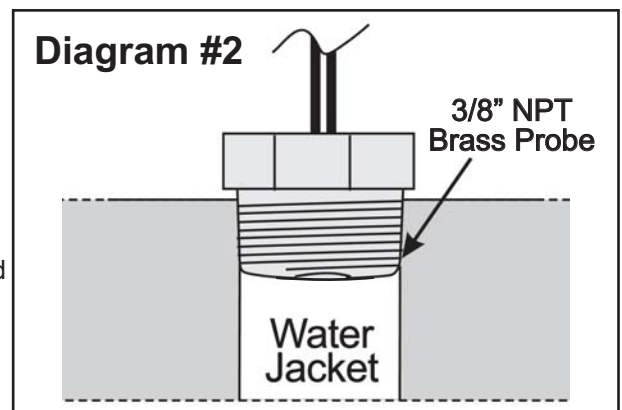
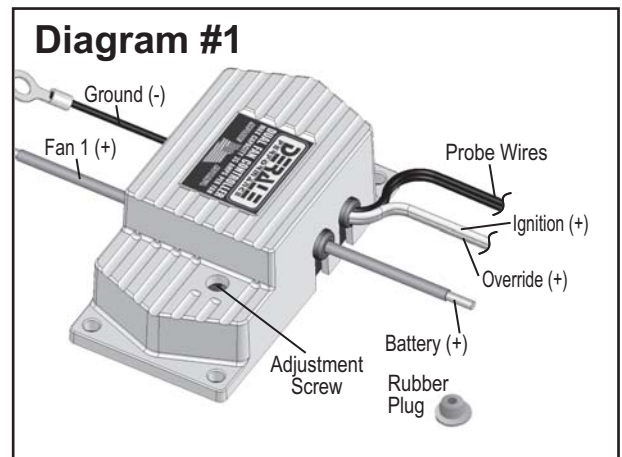

WIRING

Before starting, disconnect the Negative (-) cable on the vehicles battery.

Using the electrical connectors and wire ties provided, follow the instructions below. (See Diagram #3 on reverse side)

Red Wire (harness side): To Positive (+) 12v Battery

1. Using the Yellow 5/16" Ring Terminal & 10 Ga. Red Wire supplied, connect one end of the red wire to the vehicles Positive (+) terminal on the battery.
2. Route the 10 Ga. Red Wire now connected to the battery to the Circuit Breaker previously installed and cut the wire to the appropriate length.
3. Using a Yellow #10 Ring Terminal, connect the 10 Ga. Red Wire to the "BAT" Terminal on the Circuit Breaker.

(Wiring Continues on reverse side)

- Using a Yellow #10 Ring Terminal, connect the auxiliary side "AUX" of the circuit breaker to another length of 10 Ga. Red Wire.
- Route the 10 Ga. Red Wire now connected to auxiliary side of the circuit breaker to the Red Wire (harness side) located on the Fan Controller and cut the wire to the appropriate length.
- Connect wire using the supplied Yellow Butt Connector.

Red Wire (opposite harness side): To Fan Positive (+) Electric Fan Lead

- Using a Yellow Butt Connector and the supplied 10 Ga. Red Wire, connect one end of the red wire to the Electric Fan positive (+) wire.
- Run the 10 Ga. Red Wire connected to the Electric Fan positive lead to the Red fan wire on the controller. Cut the wire to the appropriate length.
- Connect wires using one of the supplied Yellow Butt Connectors.

Black Wire (with attached ring terminal): To Chassis Ground (-)

Using Red #10 terminal connect Black Wire to a good chassis ground. The best choice is direct to the battery. **Note:** Improper grounding is the leading cause of electrical issues with vehicles. For a good connection, make sure connection clean and free of rust and paint.

Yellow Wire: To Positive (+) 12v Ignition Source

Attach the wire harness containing the yellow and green wires to the controller in the proper orientation.

Using the Blue Wire Tap Connector supplied, attach the Yellow Wire from the harness to a positive (+) switched accessory source. Do not attach direct to the alternator, starter or an ignition source.

Note: If the yellow wire is connected to a constant power source (battery) the electric fan will run after the vehicle is shut off and could run down the battery.

Green Wire: Override Circuit (Optional)

The green wire is designed to work in two different configurations. When used, this will allow the Electric Fan to be turned on regardless of the temperature of the thermostat as it simply overrides all other functions. If you choose to not use this option cut any exposed copper and tape or shrink wrap the end of the wire.

- A/C Override - Using the Blue Wire Tap Connector provided, attach the green wire to the positive lead on the A/C compressor.
- Manual Switch Override - Attach the Green Wire to the manual switch (not provided). For Manual Switch installation always

WARNING: DO NOT ADJUST TEMPERATURE UNTIL AFTER VEHICLE IS RUNNING!

VEHICLE TESTING

- Before you start the vehicle, make sure all wires are safely zip tied and away from any moving parts.
- Start the vehicle.
- If the Manual Override function is being used either turn on the A/C of the vehicle or flip the Manual Switch on. Electric Fan should start running immediately.
- Turn off the Manual Override or A/C function & allow the engine to warm up to desired operating temperature.
- If the electric fan has not turned on, take a Screw Driver and turn the Adjustment Screw counter clockwise in small increments until the first fan starts.
- Allow the electric fan to run and shut off automatically, and possibly cycle on again. If the electric fan turns on too early, turn the Adjustment Screw clockwise.
- Once you have the fan cycling on and off using the control module, take the vehicle for a short test drive. For personal preference, some additional adjustment may still be necessary.
- Make sure the Rubber Adjustment Plug is securely in place.

TEMPERATURE ADJUSTMENT

- Remove the Rubber Adjustment Plug on the Control Module. (See Diagram #1)
Note: Each full rotation of the adjustment screw will change the activation temperature by approx. 3 1/2°F.
- Turn adjustment screw counter clockwise to lower the fan turn-on temperature.
- Turn adjustment screw clockwise to raise the fan turn-on temperature.
- Replace the Rubber Adjustment Plug.

RECALIBRATING THE CONTROL MODULE

- Turn adjustment screw clockwise 22 full revolutions.
- Turn adjustment screw counter clockwise 13 full revolutions. This will calibrate the unit to approx. 180-190°F.

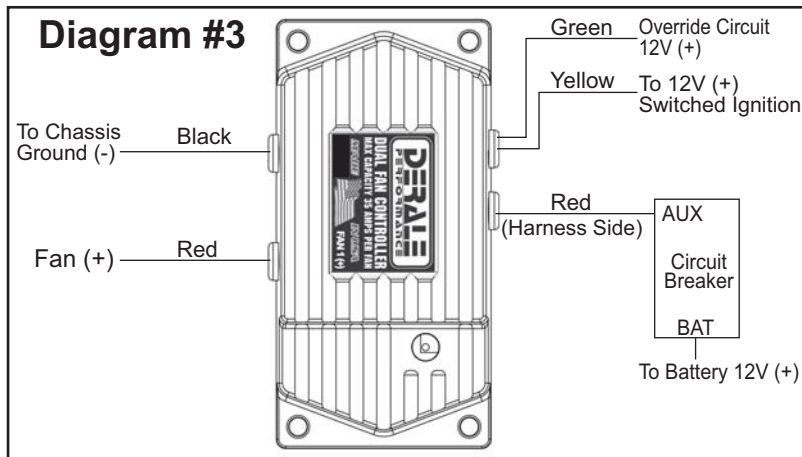

Warning: Installation of accessories should only be undertaken by those with mechanical knowledge and are familiar with working on vehicles. Always use eye protection (goggles, safety glasses or shield). Park the vehicle in a well lit area, on level ground and apply the parking brake. Only work on a cold vehicle that has been sitting overnight, failure to do so will result in severe burns and injury. Before starting the vehicle, make sure no tools or any other items are left under hood that could interfere with or be drawn into moving parts of the engine. Failure to follow instructions can lead to severe damage and personal injury.