



INSTALLATION INSTRUCTIONS ADJUSTABLE THERMOSTAT SWITCH PART # 16769

Please read these instructions completely before beginning installation

KIT CONTENTS

QTY.	DESCRIPTION	QTY.	DESCRIPTION	QTY.	DESCRIPTION
1	Thermostat Switch & Probe	2	#10 Sheet Metal Screws	1	Blue Wire Tap Connector
1	Thermostat Bracket	1	Spool Extra Wire	3	Blue Butt Connectors
1	1 1/2" x 1/2" Foam Pad	1	#10 Blue Ring Terminal	2	Blue Female Connectors
2	M4-0.7 Philips Head Bolts			4	4" Zip Ties

TOOLS NEEDED

Standard Screw Driver
Drill
5/32" Drill Bit
12V Test Light
Wire Stripper
Crimping Tool
Wire Cutter Pliers

THERMOSTAT SWITCH MOUNTING

1. Using the two M4-0.7 Philips Head Screws, attach the Mounting Bracket to the Thermostat Switch. (See Diagram #1)
2. Locate the Thermostat Switch in an accessible location near the radiator inlet hose.

Note: The Capillary Tube Probe Cannot be lengthened or cut in any way.

3. Using the Mounting Bracket as a guide, mark and drill two 5/32" holes.
4. Using the two #10 Sheet Metal Screws provided, attach the Thermostat Switch.

THERMOSTAT PROBE INSTALLATION

Making sure the vehicles engine is cold; drain enough coolant out of the radiator so the upper radiator hose can be removed.

Warning: Coolant is a hazardous fluid, drain into container. Never open radiator cap or attempt to remove hose while motor is hot.

1. Remove radiator clamp and hose.
2. Insert thermostat probe into radiator hose. (See Diagram #2)
3. Place capillary tube on radiator inlet tube so the probe itself will remain positioned in the hose. Place the foam pad between the capillary tube and the radiator inlet tube. (See Diagram #2)
4. Carefully install radiator hose and tighten hose clamp.
Note: It is recommended that a screw type hose clamp is used for correct sealing (See Diagram #3). Factory type clamps can leak.
5. Double check coolant level, fill as required.

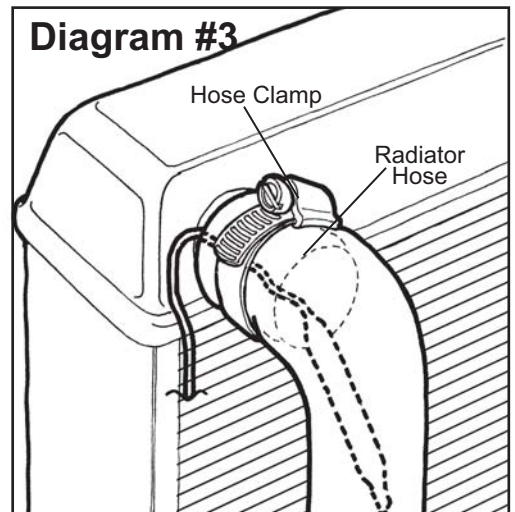
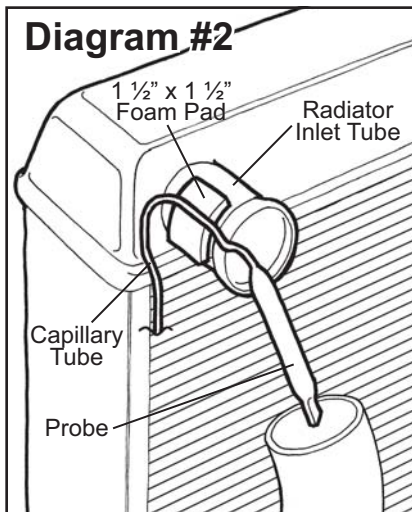
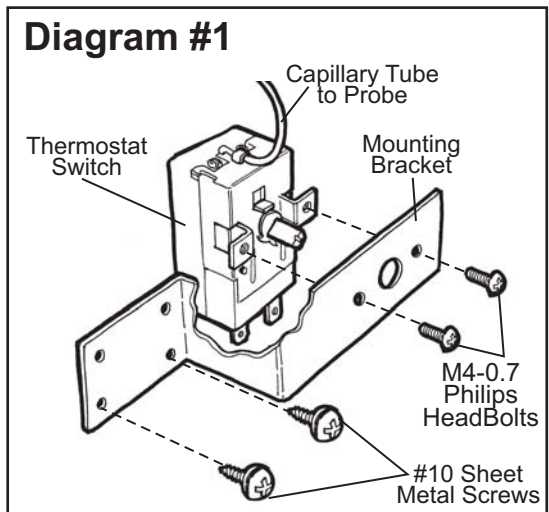

(Continues on Page 2)

WIRING

1. Disconnect the Negative (-) terminal on the vehicles battery.
2. Using the #10 Blue Ring Terminal provided, attach the Negative (-) electric fan lead to a good Chassis Ground (-).
3. Using the extra Wire, Blue Female Connector, 20 Amp Fuse Holder (not provided) and Blue Butt Connectors provided, attach the Positive (+) electric fan lead to the RIGHT terminal on the Thermostat Switch. (See Diagram #4)
4. Using the extra Wire, Blue Female Connector and Blue Wire Tap Connector provided, attach the LEFT terminal on the Thermostat Switch to a 12V Positive (+) Switched Ignition Source.
5. Reattach the Negative (-) terminal on the vehicles battery.

ADJUSTING THE TEMPERATURE

Adjustment range is 32°F to 240°F

Higher turn-on temperature: Turn the adjuster clockwise.

Lower turn-on temperature: Turn the adjuster counter clockwise.

Adjust the thermostat to desired setting by turning the brass adjuster with a flathead screwdriver.

Note: Knob not included.

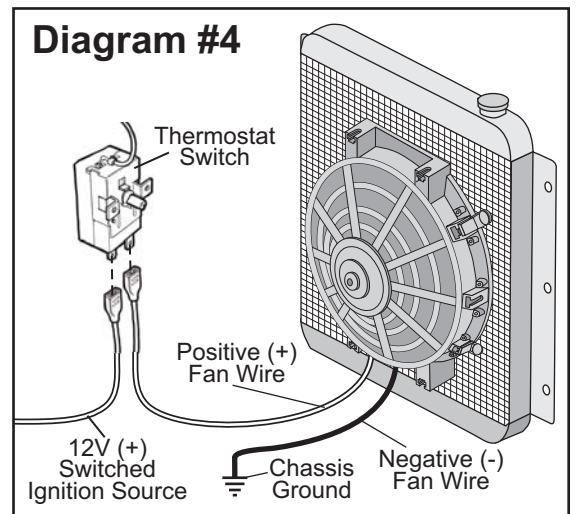

(Page 2)

Warning: Installation of accessories should only be undertaken by those with mechanical knowledge and are familiar with working on vehicles. Always use eye protection (goggles, safety glasses or shield). Park the vehicle in a well lit area, on level ground and apply the parking brake. Only work on a cold vehicle that has been sitting overnight, failure to do so will result in severe burns and injury. Before starting the vehicle, make sure no tools or any other items are left under hood that could interfere with or be drawn into moving parts of the engine. Failure to follow instructions can lead to severe damage and personal injury.