



INSTALLATION INSTRUCTIONS

SINGLE STAGE ELECTRIC FAN THERMOSTAT

PART # 16738

Please read these instructions completely before beginning installation

KIT CONTENTS

QTY.	DESCRIPTION	QTY.	DESCRIPTION
1	Thermostat Switch	1	Blue 5/16" Ring Terminal
1	Relay Wire Harness	3	Blue #10 Ring Terminal
1	Push-in Probe	2	Blue Butt Connectors
1	1 x 1 Foam Pad	2	Blue Female Connectors
1	Retaining Clip	2	Blue Wire Tap Connectors
4	4" Wire Ties	4	#10 Sheet Metal Screw

TOOLS NEEDED

12V Test Light	Standard Screw Driver or a 5/16" Nut Driver
Wire Stripper	Drill
Crimping Tool	5/32" Drill Bit

IMPORTANT

This single stage electric fan thermostat will control up to two different fans with a **COMBINED MAXIMUM DRAW OF 25 CONTINUOUS AMPS**. If fans exceed 25 amps combined we recommend using one switch per fan.

THERMOSTAT PROBE INSTALLATION

Placement: For best results we recommend installing the probe as close as possible to the water inlet of the radiator.

Installation:

1. Take the Push-in Probe and thread it clockwise onto the Thermostat Switch.
2. Carefully insert the probe/thermostat assembly into the fins of the radiator until Thermostat Switch is flush with radiator.
3. Install the 1 x 1 Foam Pad onto the Push-in Probe.
4. Install Retaining Clip onto the Push-in Probe until tight. (See Diagram #1)

RELAY WIRE HARNESS MOUNTING

1. Taking into consideration probe placement and wire routing requirements, choose a convenient location. Avoid mounting near HOT engine components.
2. Using the relay bracket as a template, mark and drill a 5/32" hole in the proper location.
3. Using the #10 Sheet Metal Screws provided, install the relay/wire harness.

Diagram #1

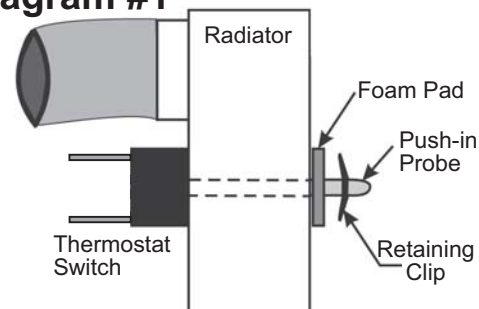

WIRING

Before starting, disconnect the Negative (-) cable on the vehicles battery.

Using the electrical connectors and wire ties provided, follow the directions below.

WARNING: When extending wires always use the identical gauge wire as provided.

Reference Diagrams # 2 & 3 on page 2.

Red: Using the Blue 5/16" Ring Terminal provided attach to the Positive (+) terminal of the battery.

Black: Using the Blue #10 Ring Terminal and #10 Sheet Metal Screw provided attach to a good chassis ground (-).

Yellow Wire: Using the Blue Female Connector provided attach to EITHER of the two terminals on the thermostat.

Thermostat Wire: Using the Blue Wire Tap and Blue Female Connector provided attach the remaining Thermostat terminal to a 12V switched ignition source.

Warning: Attaching this wire directly to a 12V non-switched source will allow the fan to run after the vehicle has been turned off which could effect the vehicles battery performance.

Green (Optional): The green wire is designed to work in two different configurations. When used, this will allow the fan(s) to be turned on regardless of the temperature of the thermostat as it simply overrides all other functions. If you choose to not use this option disregard the wire.

1. A/C Override - Using the Blue Wire Tap provided, attach the green wire to the positive lead on the air conditioning compressor.
2. Manual Switch Override - Attach the Green Wire to the manual switch NOT PROVIDED. **See Diagram #4 on reverse side.**
For Manual Switch installation always follow manufactures instructions.

SINGLE FAN CONFIGURATION

Orange Wire: Attach to a 30 Amp fused Circuit (Fuse not included), after the fuse connection attach to the Positive Electric Fan Lead (Fan +).

Negative Fan Wire: Using a Blue Ring Terminal provided, attach Negative (-) electric fan lead to a good chassis ground (-).
Reattach the Negative (-) cable on the vehicles battery.

DUAL FAN CONFIGURATION

Orange Wire: Attach to a 30 Amp fused Circuit (Fuse not included), after the fuse connection attach to the Positive Electric Fan Leads (Fan +).

Negative Fan Wires: Using a Blue Ring Terminal provided, attach BOTH Negative (-) electric fan leads to a good chassis ground (-).
Reattach the Negative (-) cable on the vehicles battery.

(Continues on reverse side)

Diagram #2

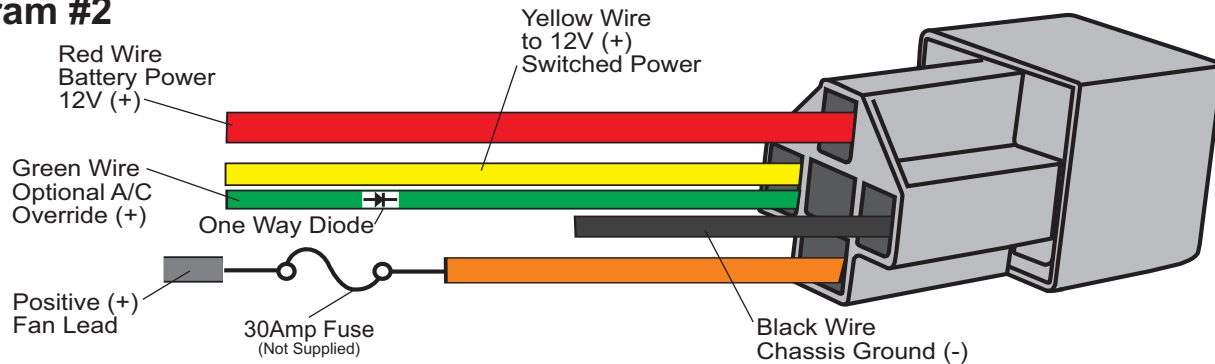

IMPORTANT: This single stage electric fan thermostat will control up to two different fans with a **COMBINED MAXIMUM DRAW OF 25 CONTINUOUS AMPS**. If fans exceed 25 amps combined we recommend using one switch per fan.

Diagram #3

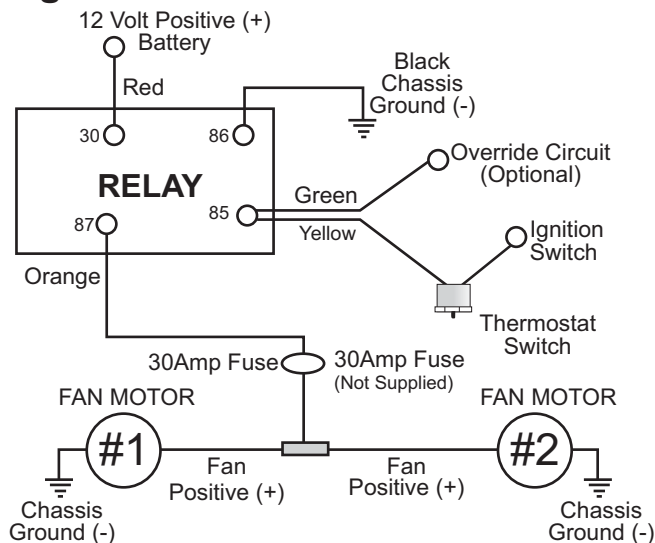
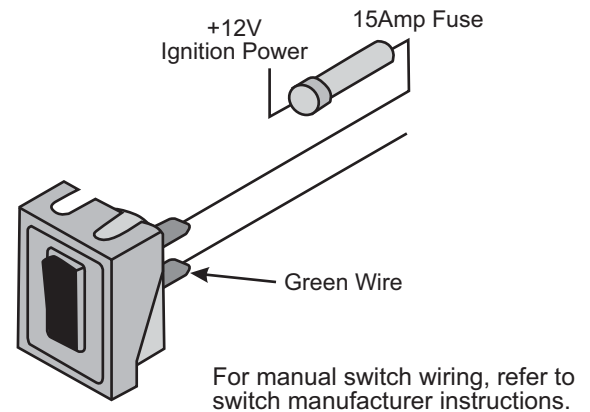

Diagram #4

Manual Switch Override Instructions (Switch Not Included)



TROUBLE SHOOTING Q&A

Q: Why doesn't the fan(s) turn on?

A: 1. Check all connections to make sure all contacts are crimped correctly.

2. Check all Ground (-) connections to make sure all paint is sanded off and you are getting a metal to metal contact.

Q: Why does the fan(s) run after the engine is turned off?

A: Check the wire going to the Thermostat Switch, this wire should be connected to a 12V Positive (+) switched ignition source.

Q: Why doesn't the fan(s) turn on when I use the Override function?

A: To quickly test the Override circuit, disconnect the Green Wire and run a jumper wire directly to the Positive (+) terminal on the battery. The electric fan should start immediately. If fan started, reattach the Green Wire to the proper (+) wire on the A/C clutch or Manual Switch.

Warning: Installation of accessories should only be undertaken by those with mechanical knowledge and are familiar with working on vehicles. Always use eye protection (goggles, safety glasses or shield). Park the vehicle in a well lit area, on level ground and apply the parking brake. Only work on a cold vehicle that has been sitting overnight, failure to do so will result in severe burns and injury. Before starting the vehicle, make sure no tools or any other items are left under hood that could interfere with or be drawn into moving parts of the engine. Failure to follow instructions can lead to severe damage and personal injury.