



INSTALLATION INSTRUCTIONS TORNADO ELECTRIC FAN KIT PART # 16620 & 16624

Please read these instructions completely before beginning installation

KIT CONTENTS

QTY.	DESCRIPTION
1	Electric Fan Assembly
4	Mounting Rod
4	Mounting Clip
4	1x1 Foam Pad

TOOLS NEEDED

Standard Screw Driver
12V Test Light
Wire Stripper
Crimping Tool
Dyke Pliers

IMPORTANT

This fan assembly is designed for both PUSHER and PULLER applications.

To change airflow direction from the factory setting, you **MUST** follow the directions below or performance will be compromised. (See Diagram #1)

PRE-INSTALLATION

Important: Tornado Electric Fans come from the factory with a product label installed on one end of the fan shroud. Before installation check the product label to confirm airflow direction and positive electric fan lead color. Airflow direction will be shown with an arrow.

This fan is factory setup for PULLER applications

Changing airflow direction

To change the airflow direction from the factory setting:

1. Remove the Nut or Clip that holds the electric fan blade onto the motor shaft.
2. Carefully remove the fan blade from the motor shaft.

Note: This is an interference fit and requires some effort.

3. Flip the fan blade upside down and reinstall onto the motor shaft. Make sure the roll pin on the motor shaft is aligned with the slot on the fan blade.
4. Reinstall nut or clip on motor shaft.

Important: For Puller applications use the referenced wire colors stated on the Product Label. For Pusher applications the two wires **MUST** be reversed to change airflow direction.

Diagram #1

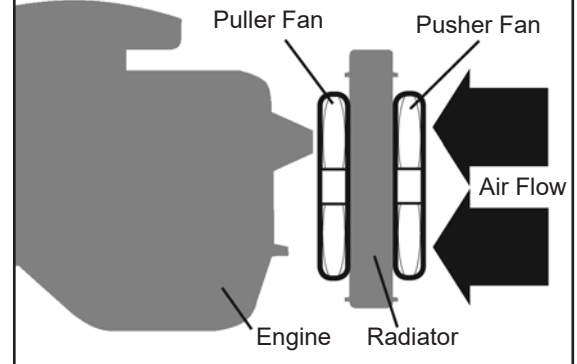

ELECTRIC FAN MOUNTING

Note: This Electric Fan Assembly requires 4 mounting positions. (See Diagram #2)

1. Position the electric fan against the radiator in the desired location.
2. Take the Plastic Rods provided and install through the mounting holes on the shroud pushing them slowly into and through the radiator core.

Caution: Do not use excessive force when pushing Plastic Rods through radiator core. Excessive force could cause Damage to the radiator fins and/or core. Plastic Rods should not be inserted thru both the radiator and the condenser cores.

3. Take the 1 x 1 Foam pads provided and install them onto the Plastic Rods now protruding through the radiator core.
4. Take the Plastic Clips provided, making sure they are in the correct direction (Derale writing out) install onto the Plastic Rods and cinch them until the 1 x 1 Foam Pads are compressed.
5. Cut off the excess Plastic Rod.

Diagram #2

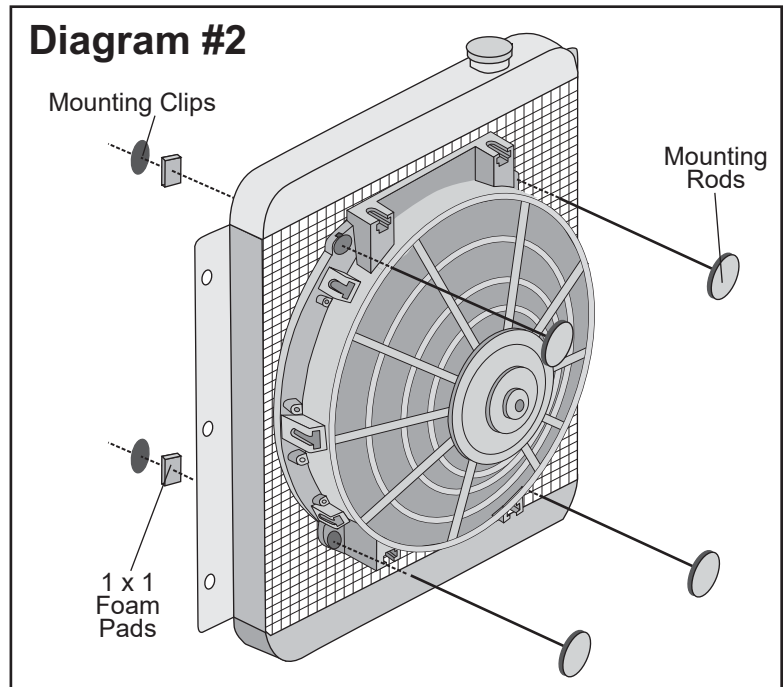

(Continues on Page 2)

TYPICAL MANUAL SWITCH WIRING

MANUAL SWITCH AND ELECTRICAL COMPONENTS NOT INCLUDED.

Important: Before beginning reference the Product Label on the Electric Fan for the factory fan configuration and Positive fan lead color. If you wish to configure the Electric Fan opposite of the factory setting, the Positive (+) and Negative (-) Electric Fan leads MUST be switched.

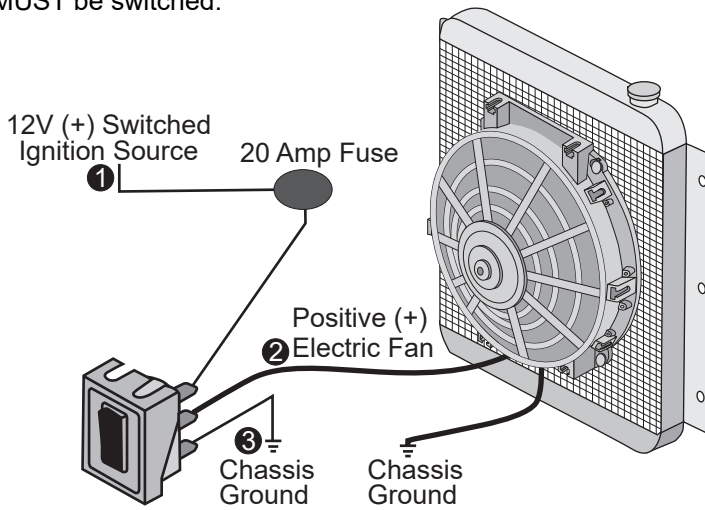

TROUBLESHOOTING Q&A

Q: Why is the Electric Fan blowing in the wrong direction?

A: Switch the Positive (+) and Negative (-) Electric Fan leads. This will reverse the airflow direction.

(Page 2)

Warning: Installation of accessories should only be undertaken by those with mechanical knowledge and are familiar with working on vehicles. Always use eye protection (goggles, safety glasses or shield). Park the vehicle in a well lit area, on level ground and apply the parking brake. Only work on a cold vehicle that has been sitting overnight, failure to do so will result in severe burns and injury. Before starting the vehicle, make sure no tools or any other items are left under hood that could interfere with or be drawn into moving parts of the engine. Failure to follow instructions can lead to severe damage and personal injury.