



INSTALLATION INSTRUCTIONS ELECTRIC FAN WITH THERMOSTAT KIT PART # 16308-16316

Please read these instructions completely before beginning installation

KIT CONTENTS

QTY.	DESCRIPTION	QTY.	DESCRIPTION
1	Electric Fan Assembly	2	#10 Sheet Metal Screws
4	Mounting Rods	1	Spool Extra Wire
4	Mounting Feet	1	#10 Blue Ring Terminal
4	1 x 1 Foam Pads	1	5/16 Ring Terminal
4	Mounting Clips	1	Blue Wire Tap Connector
1	Thermostat Switch & Probe	3	Blue Butt Connectors
1	Thermostat Bracket	2	Blue Female Connectors
1	1 1/2" x 1/2" Foam Pad	4	4" Zip Ties
2	M4-0.7 Philips Head Bolts		

TOOLS NEEDED

Standard Screw Driver
Drill
5/32" Drill Bit
12V Test Light
Wire Stripper
Crimping Tool
Dyke Pliers

Diagram #1

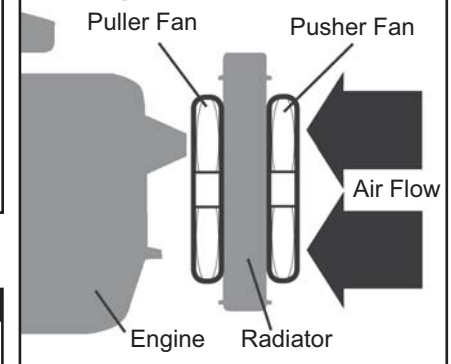

IMPORTANT

This fan assembly is designed for both PUSHER and PULLER applications.

To change airflow direction from the factory setting, you MUST follow the directions below or performance will be compromised. (See Diagram #1)

PRE-INSTALLATION

Important: All Dyno-Cool Electric Fans come with a product label factory installed on one end of the fan shroud. Before installation check the product label to confirm airflow direction. Airflow direction will be shown with an arrow.

8", 10", 12" & 14" Fans

Factory setup for PULLER applications

16" Fan

Factory setup for PUSHER applications

Changing airflow direction

To change the airflow direction from the factory setting:

1. Remove the Nut or Clip that holds the electric fan blade onto the motor shaft.
2. Carefully remove the fan blade from the motor shaft.

Note: This is an interference fit and requires some effort.

3. Flip the fan blade upside down and reinstall onto the motor shaft. Make sure the roll pin on the motor shaft is aligned with the slot on the fan blade.
4. Reinstall nut or clip on motor shaft.

Important: For Puller applications use the referenced wire colors stated on the Product Label. For Pusher applications the two wires MUST be reversed to change airflow direction.

ELECTRIC FAN MOUNTING

1. Take the four supplied Mounting Feet and install them onto the Fan Shroud in the desired locations around the perimeter of the shroud. (See Diagram #2)
2. Position the Fan Assembly against the radiator or air conditioning condenser.
3. Take the four Mounting Rods and carefully install them through the Mounting Feet and then through EITHER the radiator or air conditioning condenser. (See Diagram #2 & 3)

Caution: Do not use excessive force when installing Mounting Rods; damage to the radiator or condenser tubes could occur.

4. Take the four 1 x 1 Foam Pads and remove the paper backing. Now install them (sticky side toward the core) onto the Mounting Rods now protruding through the radiator or air conditioning condenser. (See Diagram #3)
5. Take the four Mounting Clips supplied and install them onto the Mounting Rods. The Mounting Clips can only be used one time, so make sure the Fan Assembly is in the correct location. (See Diagram #3)
6. Secure Mounting Clips until 1 x 1 Foam Pads are slightly compressed.
7. Cut off any excess Mounting Rod.

Diagram #2

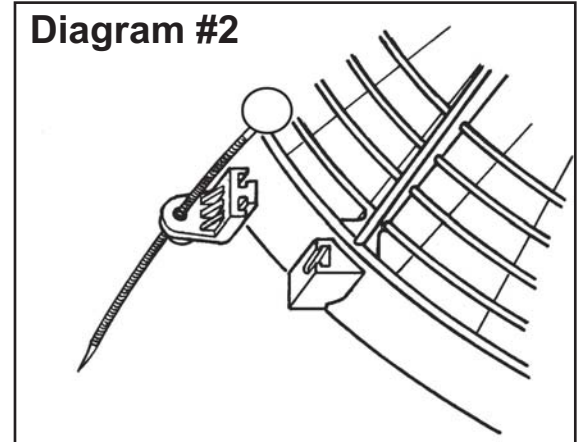

Diagram #3

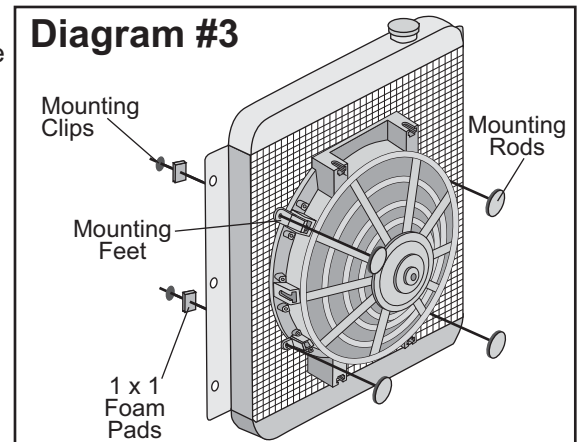

Diagram #4

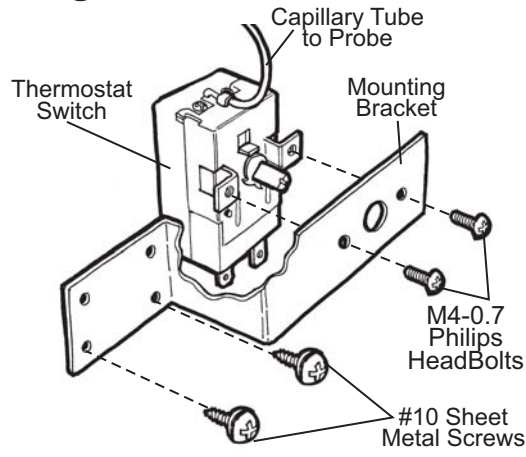

Diagram #5

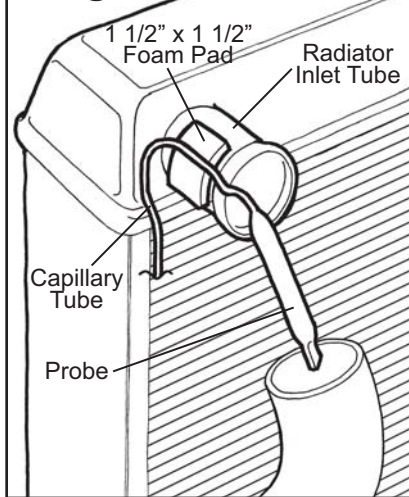
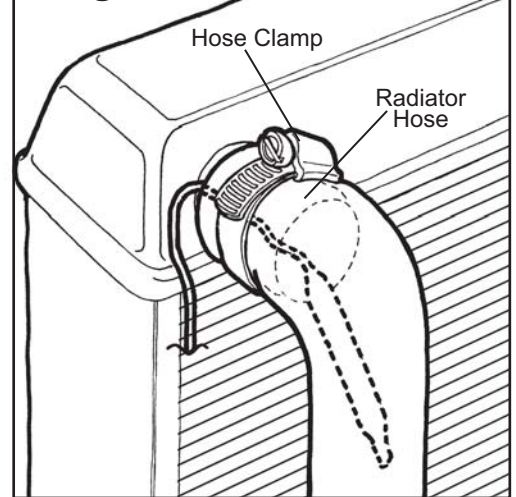

Diagram #6



THERMOSTAT SWITCH MOUNTING

1. Using the two M4-0.7 Philips Head Screws, attach the Mounting Bracket to the Thermostat Switch. (See Diagram #4)
2. Locate the Thermostat Switch in an accessible location near the radiator inlet hose.

Note: The Capillary Tube Probe Cannot be lengthened or cut in any way.

3. Using the Mounting Bracket as a guide, mark and drill two 5/32" holes.
4. Using the two #10 Sheet Metal Screws provided, attach the Thermostat Switch.

THERMOSTAT PROBE INSTALLATION

Making sure the vehicles engine is cold; drain enough coolant out of the radiator so the upper radiator hose can be removed.

Warning: Coolant is a hazardous fluid, drain into container. Never open radiator cap or attempt to remove hose while motor is hot.

1. Remove radiator clamp and hose.
2. Insert thermostat probe into radiator hose. (See Diagram #5)
3. Place capillary tube on radiator inlet tube so the probe itself will remain positioned in the hose. Place the foam pad between the capillary tube and the radiator inlet tube. (See Diagram #5)
4. Carefully install radiator hose and tighten hose clamp.
Note: It is recommended that a screw type hose clamp is used for correct sealing (See Diagram #6). Factory type clamps can leak.
5. Double check coolant level, fill as required.

WIRING

1. Disconnect the Negative (-) terminal on the vehicles battery.
2. Using the #10 Blue Ring Terminal provided, attach the Negative (-) electric fan lead to a good Chassis Ground (-).
3. Using the extra Wire, Blue Female Connector, 30 Amp Fuse Holder (Fuse holder not included) and Blue Butt Connectors provided, attach the Positive (+) electric fan lead to the RIGHT terminal on the Thermostat Switch. (See Diagram #7)
4. Using the extra Wire, Blue Female Connector and Blue Wire Tap Connector provided, attach the LEFT terminal on the Thermostat Switch to a 12V Positive (+) Switched Ignition Source.
5. Reattach the Negative (-) terminal on the vehicles battery.

Diagram #7

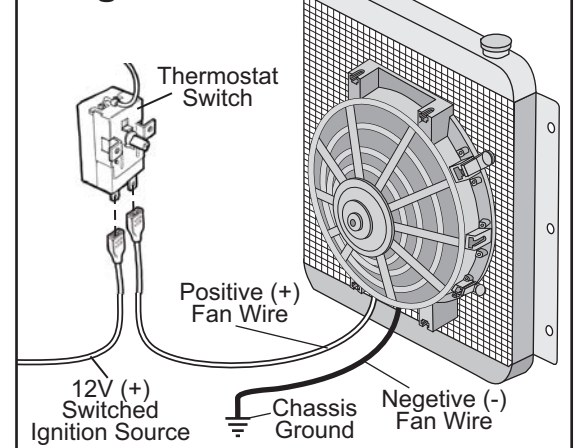

ADJUSTING THE TEMPERATURE

Adjustment range is 32°F to 240°F

Higher turn-on temperature: Turn the adjuster clockwise.

Lower turn-on temperature: Turn the adjuster counter clockwise.

Adjust the thermostat to desired setting by turning the brass adjuster with a flathead screwdriver.

Note: Knob not included.

Warning: Installation of accessories should only be undertaken by those with mechanical knowledge and are familiar with working on vehicles. Always use eye protection (goggles, safety glasses or shield). Park the vehicle in a well lit area, on level ground and apply the parking brake. Only work on a cold vehicle that has been sitting overnight, failure to do so will result in severe burns and injury. Before starting the vehicle, make sure no tools or any other items are left under hood that could interfere with or be drawn into moving parts of the engine. Failure to follow instructions can lead to severe damage and personal injury.