



# INSTALLATION INSTRUCTIONS H.O. EXTREME ELECTRIC FAN KIT PART # 16112, 16114, 16142 & 16136

Please read these instructions completely before beginning installation

### KIT CONTENTS

QTY.	DESCRIPTION
1	Electric Fan Assembly
4	Mounting Rod
4	Mounting Clip
4	Mounting Feet
4	1x1 Foam Pad

### TOOLS NEEDED

Standard Screw Driver  
12V Test Light  
Wire Stripper  
Crimping Tool  
Dyke Pliers

### IMPORTANT

This fan assembly is designed for PULLER (engine side) applications only.

### ELECTRIC FAN MOUNTING

**Note:** This Electric Fan Assembly requires 4 mounting positions. Four Mounting Rods will be installed with the 4 supplied Mounting Feet. (See Diagram #2)

1. Identify the 4 Mounting Feet supplied and install onto the Electric Fan Assembly by sliding them into the slots on the Electric Fan Assembly. See Diagram #2
2. Position the electric fan against the radiator in the desired location.
3. Take the Plastic Rods provided and install through the mounting holes on the shroud pushing them slowly into and through the radiator core.

**Caution:** Do not use excessive force when pushing Plastic Rods through radiator core. Excessive force could cause damage to the radiator fins and/or core. Plastic Rods should not be inserted thru both the radiator and the condenser cores.

4. Take the 1 x 1 Foam pads provided and install them onto the Plastic Rods now protruding through the radiator core.
5. Take the Plastic Clips provided, making sure they are in the correct direction (Deraled writing out) install onto the Plastic Rods and cinch them until the 1 x 1 Foam Pads are compressed.
6. Cut off the excess Plastic Rod.

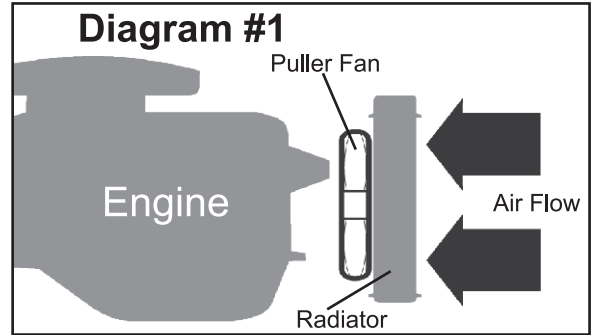

### Diagram #2

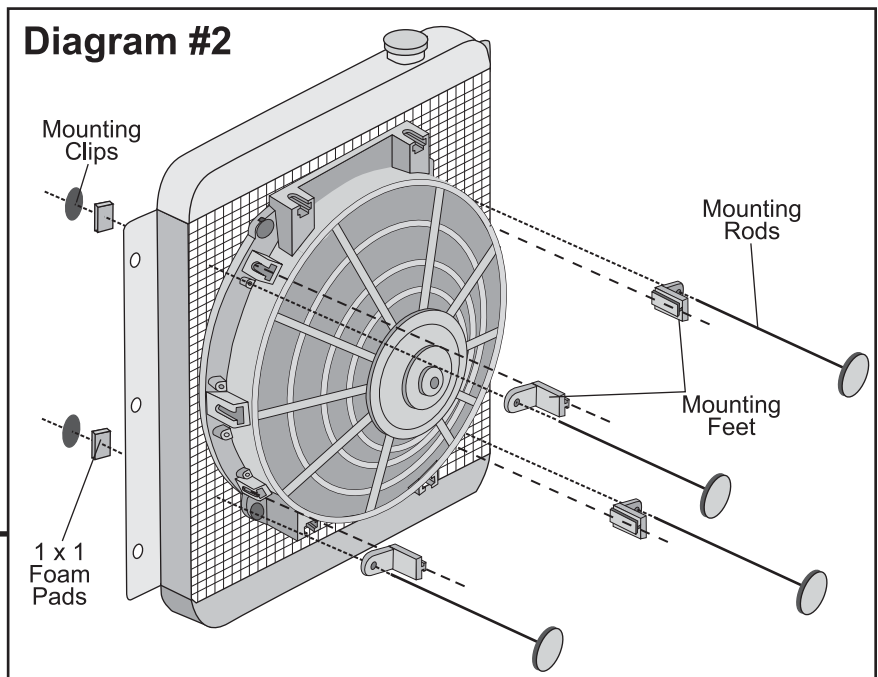

### WIRING

This fan is designed for use on a 12V system. It can be used as a puller fan with the wires configured as indicated below.

Positive 12V Wire (+): Blue (Part # 16110: Blue)

Negative Wire (-): Black

### TYPICAL MANUAL SWITCH WIRING MANUAL SWITCH AND ELECTRICAL COMPONENTS NOT INCLUDED.

**Important:** Before beginning reference the Product Label on the Electric Fan for the factory fan configuration and Positive fan lead color. If you wish to configure the Electric Fan opposite of the factory setting, the Positive (+) and Negative (-) Electric Fan leads MUST be switched.

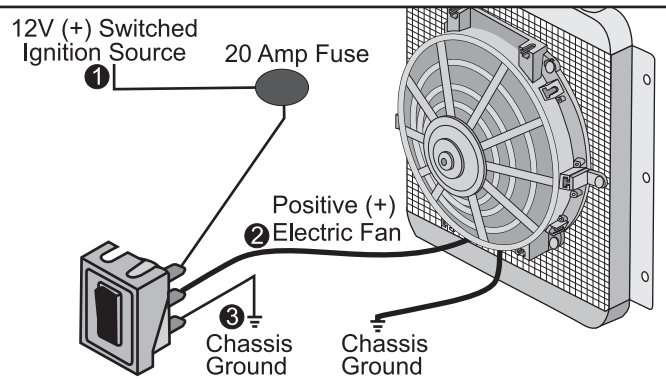

**Warning:** Installation of accessories should only be undertaken by those with mechanical knowledge and are familiar with working on vehicles. Always use eye protection (goggles, safety glasses or shield). Park the vehicle in a well lit area, on level ground and apply the parking brake. Only work on a cold vehicle that has been sitting overnight, failure to do so will result in severe burns and injury. Before starting the vehicle, make sure no tools or any other items are left under hood that could interfere with or be drawn into moving parts of the engine. Failure to follow instructions can lead to severe damage and personal injury.