



**Collision Repair Equipment and
Tools for Premier Body Shops**



TABLE OF CONTENTS



ALUMINUM REPAIR
PAGE 04



STEEL REPAIR
PAGE 20



PLASTIC REPAIR
PAGE 40



PAINT LESS DENT REPAIR (PDR)
PAGE 56



MEASUREMENT
PAGE 60



SHOP TOOLS & DETAIL
PAGE 64

©2020 DENT FIX EQUIPMENT

Dent Fix Equipment name, Dent Fix Equipment logo, and DF Dot logo are property of Dent Fix Corporation. All rights reserved. Dent Fix trademarks and slogans are not be used unless a written approval letter is issued by Dent Fix Equipment.

ALUSPOT ALUMINUM REPAIR STATION - DXE

Simply the BEST

Since 2006 we have been perfecting the most capable aluminum stud welding repair station. This is our most complete unit.

The DF-900DX/E Aluspot Extended includes everything that the Ford Approved Aluspot (DF-900DX) has PLUS Aluminum-Head Hammer Set (DF-AH714), POM Nylon Dolly Set (DF-AB712), two more storage drawers, an in-cabinet electrical

power strip, and a holster on the side of the cabinet to hang the heat gun. The most complete aluminum repair station on the market!

CONSUMABLES - See PG 9

110V

POWER

STUD WELDER: 110V
HEAT GUN: 110V
INLINE REMOVER 90PSI



INCLUDED (DF-900DX/E)

| | | | | | | |
|--|--|--|--|--|--|--|
| | | | | | | |
| | | | | | | |
| | | | | | | |
| | | | | | <p>EVERYTHING IN THE DF-900DX PLUS: ALUMINUM HAMMERS, POM DOLLY SET, POWER BANK HEAT GUN HOLSTER, & MORE DRAWERS</p> | |
| | | | | | | |

ALUSPOT ALUMINUM REPAIR STATION - DXE



Side cable opening allows for gun cable to hang away from the drawers

WARRANTY
5
YEAR

Made In
USA

**SATISFIES THE
PANEL REPAIR
SYSTEM
REQUIREMENT
FOR FORD AND
TESLA BODY
SHOP REPAIR
PROGRAMS**

| | | |
|------|---|----------|
| | | |
| 110v | 5 | 280 lbs. |

ALUSPOT ALUMINUM REPAIR STATION - DX

Proven Solutions

Since 2006 AluSpot has been meeting the needs for aluminum panel repair.

The DF-900DX Aluspot Deluxe is the most complete aluminum repair station "from the name you know and trust". FORD APPROVED! Here you have everything you need for aluminum repair, within easy reach in a self-contained system. The

tools lock away so they do not wander the shop or become contaminated with the steel particles floating around the shop.

CONSUMABLES - See PG 9

110V

POWER

STUD WELDER: 110V
HEAT GUN: 110V
INLINE REMOVER 90PSI



INCLUDED (DF-900DX)

| | | | | | | |
|--|--|--|--|---|--|--|
|  DF-900W | 250 pc  Magnesium | 250 pc  Silicon | 4 pc  Pull Finger |  DF-900TP |  DF-900SP |  DF-900LP |
|  DF-900BP |  DF-358 |  DF-900HG |  DF-900PFH |  DF-900CPH |  DF-900RCH | |
|  DF-900SFH |  DF-900DBH |  DF-900BHND |  DF-900RHND |  DF-900DEND |  DF-900UTD |  DF-900TTD |
|  DF-900HLD |  DF-900CVD |  DF-700T |  DF-900SSB |  DF-900SSBS |  | |
|  DF-900BFH |  DF-900BFH |  DF-900DC | <p>SATISFIES THE PANEL REPAIR SYSTEM REQUIREMENT FOR FORD AND TESLA BODY SHOP REPAIR PROGRAMS</p> | | | |

ALUSPOT ALUMINUM REPAIR STATION - DX



| | | |
|------|---|----------|
| | | |
| 110v | 3 | 220 lbs. |

ALUSPOT ALUMINUM REPAIR STATION - MINI



Discover Aluspot

Experience the quality of a premium aluminum panel repair station without breaking the bank.



Mini but Mighty.

Any shop can invest in the future and start repairing minor to moderately damaged aluminum panels.

POWER

Aluspot Welder

The DF-900B Mini Aluspot Repair System from Dent Fix Equipment is designed to operate as the main unit or as satellite unit. The Aluspot Mini utilizes some of the same Dent Fix innovations and premier equipment as the larger Aluspot systems but at a fraction of the price. Now any shop can invest in the future and start repairing minor to moderately damaged aluminum panels.

Tool List - See PG 9



DUST COVER INCLUDED!

ALUSPOT ALUMINUM REPAIR

STUD WELDER | PULLERS | SHAPING | CONSUMABLES

STOP REPLACING ALUMINUM PANELS - REPAIR THEM AND PROFIT INSTEAD



ALUSPOT Extended
DF-900DXE



ALUSPOT Deluxe
DF-900DX



ALUSPOT Mini
DF-900B



SIDE-BY-SIDE COMPARISON

| INCLUDED | DXE | DX | B |
|---------------------------------|-----|----|---|
| 110v Cap. Discharge Stud Welder | • | • | • |
| Alu-Silicon Studs | • | • | • |
| Alu-Magnesium Studs | • | • | • |
| Spitznagel Pull Fingers | • | • | • |
| T-Puller | • | • | • |
| Squeeze Puller | • | • | |
| Leverage Puller | • | • | • |
| Bridge Puller | • | • | |
| Stud Cut Pliers | • | • | • |
| Infrared Temp. Gauge | • | • | |
| Heat Gun | • | • | |
| 3 PC Hammers (Steel) | • | • | |
| 3 PC Hammers (Alumin.) | • | | |
| 2mm Soft Face | • | • | |
| 35mm Dead Blow Hammer | • | • | |
| 2 PC Nylon Chisels | • | • | |
| 12 PC Nylon Dollies | • | | |
| 3 PC Steel Dollies | • | • | |
| Heat Gun Holster | • | • | • |
| Shoe Handle Brush | • | • | • |
| Tooth Brush | • | • | • |
| Inline Pneumatic Paint Remover | • | • | |
| Fiber Discs | • | • | |
| Power Strip | • | • | • |
| 5 Year Warranty | • | • | • |
| Body File + 350mm Blade | • | • | |
| Safety Glasses | • | • | • |
| 5 Drawers | • | | |
| 3 Drawers | | • | |
| Dust Cover | • | • | • |

REPLACEMENTS



ALU-MAGNESIUM STUDS
M4x25 | 500 pc
DF-900PM/500



ALU-SILICON STUDS
M4x25 | 500 pc
CF-900PS/500



PULL FINGERS
1 PIECE
DF-900PF



FIBER DISCS
6 PIECE
DF-710BW



REPLACEMENT B.LADE
1 PIECE
DF-900BFH

Drawn Arc-Weld

means stronger weld with minimal penetration to the underside of the panel. Argon gas shielding creates a contaminant free weld.

The **DF-900ARC/DXE AluArc Extended** is the next advancement in aluminum repair. Capable of creating extremely strong welds with minimal back panel penetration. With lift arc welding the key is lifted from the panel creating an arc that melts the tip

of the key, which then drops to the panel fusing it with panel. The host panel is not used. Because keys can be welded straight into crease, your pulls will be more precise and effective. Keys have great strength for heavy pulls.

CONSUMABLES - See PG 13

110V

POWER

KEY WELDER: 110V
HEAT GUN: 110V
INLINE REMOVER: 90PSI



INCLUDED (DF-900ARCDXE)

| | | | | | | |
|---|--|--|---|---|--|--|
|  DF-900ARC | 100 pc  Flat Keys | 50 pc  Twisted Keys |  DF900TP |  DF-900SP |  DF-900LP | |
|  DF-900BP | |  DF-358 |  DF-900HG |  DF-900PFH |  DF-900CPH |  DF-900RCH |
|  DF-900SFH |  DF-900DBH |  DF-900BHND |  DF-900RHND |  DF-900DEND |  DF-900UTD |  DF-900TTD |
|  DF-900HLD |  DF-900CVD |  DF-700T |  DF-900SSB |  DF-AH714 | | DELUXE MODEL: Aluminum Hammers, POM Dolly Set, Powerbank, Heat Gun Holster, & MORE DRAWERS |
|  DUST COVER |  DF-900BFH |  DF-900BFH |  DF-900SSBS |  DF-AB712 | | |

ALUARC ALUMINUM REPAIR STATION - DXE



Weld Keys Close

For heavy pulls, multiple keys create an extremely strong pulling tab.



Maximum Bottle:
80 Cubic Feet Bottle
NOT INCLUDED

| VOLTAGE | DRAWERS | CONSUMABLE GAS |
|---------|---------|----------------------|
| 110v | 5 | ARGON (NOT INCLUDED) |

ALUARC ALUMINUM REPAIR STATION - MINI



Weld Keys Close

For heavy pulls multiple keys create an extremely strong pulling tab.

DF-900ARC/B

Small but Mighty

Superior performance packed into a compact package.

110V

POWER

Aluarc Welder
GAS: ARGON (Not Included)

The DF-900ARC/B Mini AluArc Aluminum Repair System is designed to operate as the main unit or as satellite unit and utilizes some of the same Dent Fix innovations and premier equipment as the larger AluArc systems but at a fraction of the cost. Now, any shop can invest in the future and start repairing minor to moderately damaged aluminum panels.

Tool List &
Consumables - PG 13



ALUARC ALUMINUM REPAIR

KEY WELDER | PULLERS | SHAPING | CONSUMABLES

STOP REPLACING ALUMINUM PANELS - REPAIR THEM AND PROFIT INSTEAD



ALUARC Extended
DF-900ARC DX/E



ALUARC Mini
DF-900ARC/B

ARC

WELD KEYS



FLAT
100 pc



TWISTED
50 pc

| | | |
|-----------|---------------------------|---------------------------|
| 1.0 mm | AlSpec N°1 DF-ARC535 | AlSpec N°1 DF-ARC542 |
| | AlMgSi N°2 DF-ARC498 | AlMgSi N°2 DF-ARC504 |
| | AlMg N°3 DF-ARC450 | AlMg N°3 DF-ARC467 |
| 1.5 mm | AlSpec N°4 DF-ARC559 | AlSpec N°4 DF-ARC566 |
| | AlMgSi N°5 DF-ARC511 | AlMgSi N°5 DF-ARC528 |
| | AlMg N°6 DF-ARC474 | AlMg N°6 DF-ARC481 |

AlSpec
(99.5% Aluminum)

AlMgSi
(Silicon Alloy)

AlMg
(Magnesium Alloy)

SIDE-BY-SIDE COMPARISON

| INCLUDED | DXE | B |
|--------------------------------|-----|---|
| Alu-Arc Key Welder | • | • |
| Alu-Silicon Weld Keys (AlMgSi) | • | • |
| Alu-Magnesium Weld Keys (AlMg) | • | • |
| T-Puller | • | • |
| Squeeze Puller | • | • |
| Leverage Puller | • | • |
| Bridge Puller | • | • |
| Key Cut Pliers | • | • |
| Heat Gun | • | • |
| 3 PC Hammers (Steel) | • | • |
| 3 PC Hammers (Alumin.) | • | • |
| 2mm Soft Face | • | • |
| 35mm Dead Blow Hammer | • | • |
| 2 PC Nylon Chisels | • | • |
| 12 PC Nylon Dollies | • | • |
| 3 PC Steel Dollies | • | • |
| Heat Gun Holster | • | • |
| Shoe Handle Brush | • | • |
| Tooth Brush | • | • |
| Inline Pneumatic Paint Remover | • | • |
| Fiber Discs | • | • |
| Power Strip | • | • |
| 5 Year Warranty | • | • |
| Body File + 350mm Blade | • | • |
| Weld Protection Glasses | • | • |
| 5 Drawers | • | • |
| Dust Cover | • | • |
| Tank Regulator | • | • |

ADD-ONS FOR MINI



ALUMINUM HAMMERS
1 PIECE
DF-AH714



HEAT GUN
1 PIECE
DF-900HG

ALUMINUM HAMMER SET DF-AH714

- Solid aluminum head
- Avoid cross contamination
- Lightweight with more forgiving strike
- Less likely to stretch aluminum panel
- Maintenance free



PERFECT FOR ALUMINUM
AVOID GALVANIC CORROSION
GENUINE HICKORY HANDLES

NYLON DOLLIES DF-AB712

SOLID POM NYLON
NON-CORROSIVE



12
PIECE



- Non-Corrosive - Perfect for Aluminum Repair
- Non-Marking - When working with metal
- Molded Case - Tools kept organized & clean
- Maintenance free

HAMMER-ON VS HAMMER-OFF TECHNIQUE

When used properly, the two metal working techniques are very effective at repairing aluminum panels. The hammer-off dollying technique is used when first returning the dent to the original shape. Use the first in, last out rule which means to work the dent in reverse, starting outside of the dent and working towards the point of impact. The tools best suited for hammer-off are highly polished steel hammers and rubberized steel core (DF-AB711). Aluminum can easily stretch, so use caution. Hammer-on is used by experienced technicians with lightweight aluminum hammers (DF-AH714) and Nylon dollies (DF-AB712) when smoothing the metal into its final position. Light tapping is used to finish.



RUBBERIZED DOLLIES

DF-AB711

RUBBER SHELL STEEL CORE



7
PIECE

- Rubberized - Better for soft aluminum
- Steel Core - Dense center, good heft
- Case - Dollies are isolated & protected
- Maintenance free



Air Powered

Using regulated air, consistent pneumatic pressure is applied through the installation process.

The DF-SPR67 Self-Piercing Riveter most versatile and precise riveter available. Pressure application is easily adjusted and can be consistently set with the read out dial. The pressure and speed controls increases accuracy and enable

the rivets to be inserted without panel distortion. Choice of C-clamps and dies sets creates versatility for all makes. All metal construction ensures years of use.

CONSUMABLES - See PG 19

8 Tons

PRESSURE

Pneumatic Operation
Install | Punch Hole
Flatten | Remove
Adjustable Pressure



INCLUDED (DF-SPR67)

| | | | | | |
|--|-------------------------------------|-----------------------------------|------------------------------------|---|-----------------------------------|
| <p>INCLUDED WITH DF-SPR67 Self-Piercing Riveter Kit</p> | <p>SPR - 3mm</p> <p>DF-SPR/AD</p> | <p>SPR - 5mm</p> <p>DF-SPR/BD</p> | <p>Extracting</p> <p>DF-SPR/ED</p> | <p>Hole Punch</p> <p>DF-SPR/TD</p> | <p>Flow Form</p> <p>DF-SPR/FD</p> |
| | <p>Flattening</p> <p>DF-SPR/D17</p> | <p>HR2 Arm</p> <p>DF-SPRHR2</p> | <p>SAMPLE RIVETS</p> | <p>O-Fing</p> <p>x4</p> <p>DF-SPROR</p> | <p>Wrench</p> <p>DF-SPR/WR</p> |

WHAT IS A SELF-PIERCING RIVET?

Self-Piercing Riveting (SPR) is a cold forming technique used to join two panels together with no heat or pre-drilled holes needed to install. The self-piercing rivet pierces the top sheet and forms a mechanical interlock with the bottom sheet without penetrating the back panel.

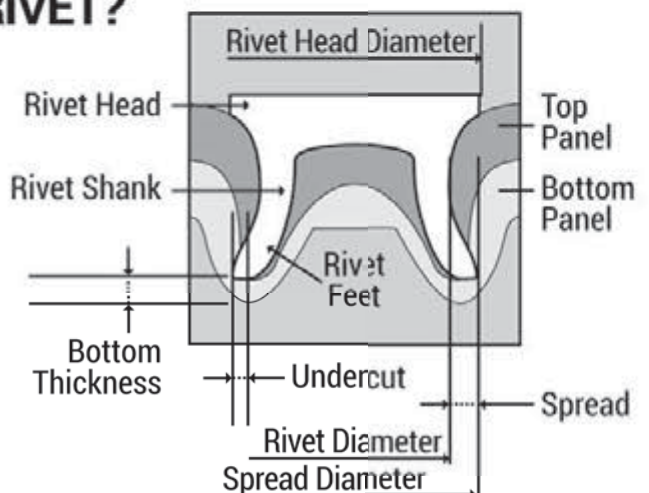

SELF-PIERCING RIVETER



- Kit Includes:
- Self-Piercing Riveter
 - HR2 Arm (DF-SPRHR2)
 - SPR Matrix Set 3mm (DF-SPR/AD)
 - SPR Matrix Set 5mm (DF-SPR/BD)
 - SPR Matrix Extracting Set (DF/SPR/ED)
 - Hole Punch Matrix Set (DF-SPR/TD)
 - Flow Form Matrix Set (DF-SPR/FD)
 - Sample Set of SPR rivets
 - Arm Locking Pin
 - Grip Handle & Shoulder Strap
 - Blow Molded Case

- Optional Upgrades:
- Low Profile Arm (DF-SPRHR1S)
 - Large Arm (DF-SPRHR3)
 - Work Stand (DF-SPR68WS)

CLAMP WEIGHT 8.05 LBS
BODY WEIGHT 7.15 LBS

Inside the Case

| | | |
|---------------------------|------------------|-----------------|
| Operation | PSI* | Capacity |
| Pneumatic | 90 Min 115 Max | 8 Bar |
| Heads | Warranty | Readout |
| SPR, Extract, Flow, Punch | 1 Year | Dial Display |

* USE AIR REGULATOR

SMALL ARM
DF-SPRHR1S



LARGE ARM
DF-SPRHR3



FORD DIE SET
DF-SPR/FORD

- Rivet set for F-Series
- Fits DF-SPR67



DENT FIX EQUIPMENT

RIVET HOLDER DIE

B1
5.3 mm
(DF-SPR/B)

DENT FIX EQUIPMENT

RECEIVING DIES

G1

G2

G3

G4

G5

G6

5.3x4.0 mm
(DF-SPR54)

Riveter Settings:
7 bar
@ 110 Psi
regulated

Examples of
SPR rivet
insertion
using the
FORD die set

BLIND RIVET ADAPTER

DF-SPR/BRAD

- Minimal clearance needed
- Position into tight spaces
- Long flexible neck



Pull Blind Rivets

Storage for
blind rivet heads
3.2 | 3.6 | 4.0 | 4.5mm



SELF PIERCING RIVETS

ZINC COATED



5.3 x 4.0mm
(100 pc)
DF-SPR54



5.3 x 5.0mm
(100 pc)
DF-SPR55



5.3 x 6.0mm
(100 pc)
DF-SPR56



5.3 x 7.0mm
(100 pc)
DF-SPR57



5.3 x 8.0mm
(100 pc)
DF-SPR58



5.3 x 9.0mm
(100 pc)
DF-SPR59

5.3 x 6.5mm
(100 pc)
DF-SPR565

5.3 x 7.5mm
(100 pc)
DF-SPR575



3.3 x 3.5mm
(200 pc)
DF-SPR33



3.3 x 4.0mm
(200 pc)
DF-SPR34



**CALL FOR NEW
BLIND RIVETS**

Game Changer

With today's thin sheet metals, The MAXI is the best way to pull without damaging the panel. Light to heavy pulls, The MAXI does it all.

The DF-505/220V MAXI Steel Dent Repair Station is a 220 volt single phase steel dent pulling station that provides the technician with the power they need to shrink, pull rocker panels, hail damage, creases, and dents in hard to access areas and all

types of metal damage. Just WELD > PULL > TWIST. The efficiency of this tool increases the workers productivity while producing a cleaner, better repair.

CONSUMABLES - See BELOW

220V

POWER

Ultimate Steel Dent Puller
Increases efficiency & productivity
WELD • PULL • TWIST



| | | | | | | | |
|--|--|--|---|---|---|--|--|
| INCLUDED WITH MAXI DENT PULLER | Pulling Rods  5.5" | Slide Hammer Rods  10" | Strike Weight  DF-503SW | Leverage Puller  DF-505L | Stud Pin Electrode  DF-503P | Wiggle Wire Tip  DF-503W | |
| | 9-Finger Claw  DF-506 | 4-Finger Claw  DF-504 | Sample Keys & Pins  | Wiggle Wire  | Grounding Magnet  DF-GM | Shrinking Electrode  DF-503S | Key Tip  DF-503KEM |
| OPTIONAL Upgrades & Re-Orders | Work Stand  DF-509 | | 2.0mm Pins  DF-20 | 2.6mm Pins  DF-26 | Flat Keys  100 pc DF-503KF | Twisted Keys  100 pc DF-503KT | |
| | 10" Weld Rods  DF-503L | | | Thin Wire  1 lb (DF-507) | Thick Wire  1 lb (DF-507TK) | Ding Massager  DF-505DM | |
| | 5.5" Weld Rods  DF-503 | | | | | | |

MAXI STEEL REPAIR STATION



*

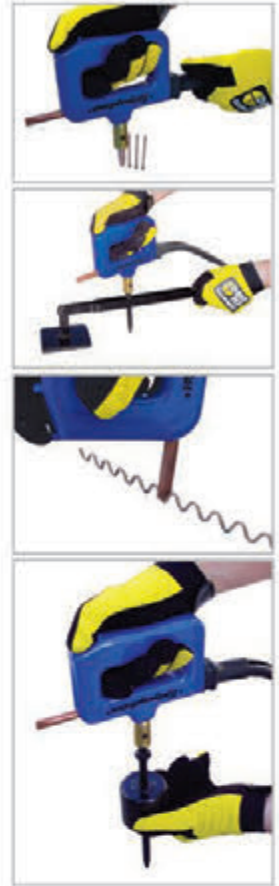

* MAXI PICTURED WITH
OPTIONAL STAND (DF-509)
PURCHASED SEPARATELY

- Kit Includes:**
- 220v Maxi Unit
 - Leverage Puller
 - x2 Pulling Rods
 - x2 Slide Hammer Rods
 - Strike Weight
 - Shrinking Electrode
 - Stud Pin Electrode
 - Wiggle Wire Welding Tip
 - Magnetic Key Tip
 - Nine-Finger Bear Claw
 - Four-Finger Bear Claw
 - x50 Sample Stud Pins
 - Sample Weld Keys
 - 1/2 lb Thick Wiggle Wire
 - 1/2 lb Thin Wiggle Wire
 - Grounding Magnet

- Optional Upgrades:**
- Machine Stand (DF-509)
 - Ding Massager (DF-505DM)
 - Dust Cover (DF-505DC)

POWER CABLE

18 FEET

PHASE

SINGLE

WELDING CABLE

9 FEET

STEEL BRIDGE PULLER

DF-505BP

- Holds pulls in place
- Locking wheel adjustment
- Simple one person operation

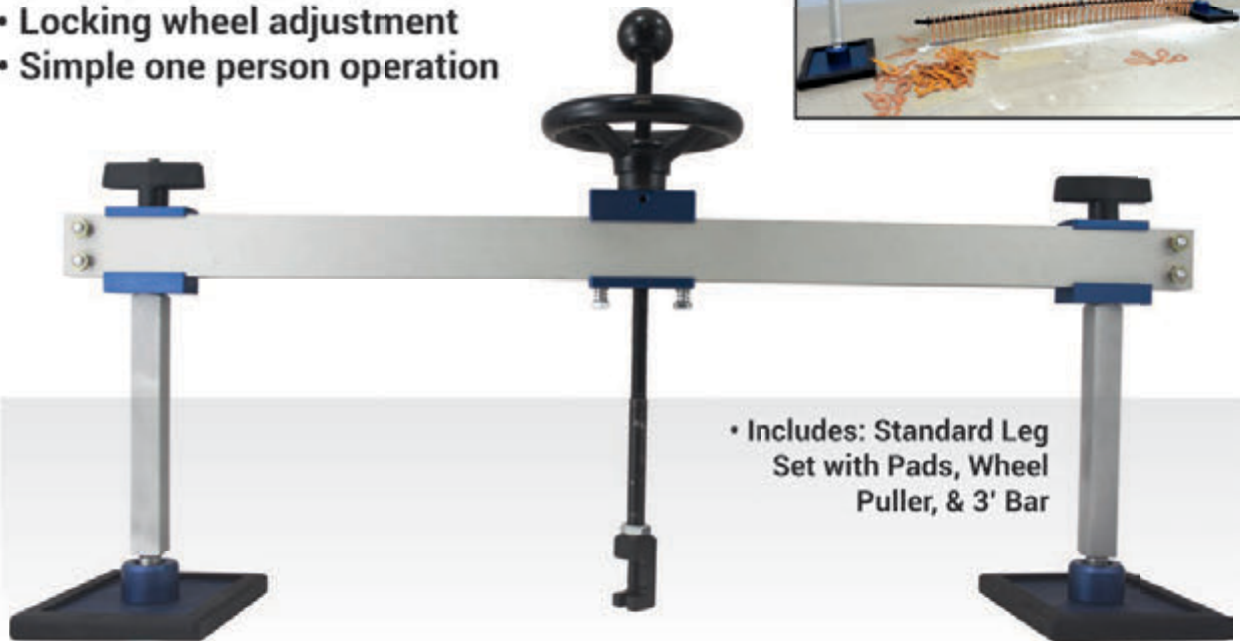
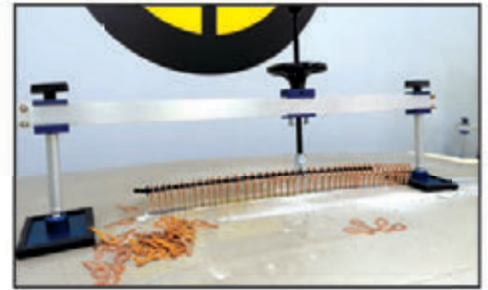

- Includes: Standard Leg Set with Pads, Wheel Puller, & 3' Bar

MAXI MASSAGER

DF-505DM

MASSAGE STEEL PULLS

1

PIECE



- Adjustable depth
- Fine finish work
- Weld rod slides in easily

Uses DF-503 short weld rod (Not Included)



MAXI DUST COVER

DF-505DC

- Protect your MAXI and keep it clean
- Durable construction should last for years
- MAXI stand not included, but needed for proper fit

OPTIONAL MAXI STAND
NEEDED TO USE COVER



DF-509

Heavy Duty
Construction with
Thick, Water
Resistant Vinyl



MAGNETIC KEY TIP

DF-503KEM



WELD KEYS WITH MAXI

1

PIECE

- Maxi (DF-505) add-on
- Weld keys for use with bridge pullers
- Includes key tip & sample keys



DF-503KF
Straight Weld Key
100 pcs



DF-503KT
Twisted Weld Key
100 pcs

Great Value

The Hammer Head gets you the pulling capabilities you need. Working the same technique as The Maxi, Weld • Pull • Twist. Efficiency and low heat signature make this a must have over conventional stud welders.

Replace your stud welder with our 110 volt **DF-595ii Hammer-Head**. This efficient unit provides the technician with the means to higher productivity and better results. It's like having sticky fingers and being able to pull dent with your hand.

The leverage puller allows for controlled pulls. The slide hammer gives you taping and wiggle wire and claw is good for crease pulling. 1 year warranty. Works with a 30 amp breaker.











CONSUMABLES - See **BELOW**

110V





POWER

Good Steel Dent Puller that increases efficiency & productivity



| | | | | | |
|------------------------------------|---|---|---|---|---|
| INCLUDED WITH DF-595ii HAMMER-HEAD | Pulling Rod  7" | Slide Hammer Rod  11" | Strike Weight  | Leverage Puller  DF-595iiLP | 4-Finger Claw  |
| | Grounding Magnet  DF-GM | 1/2lb Wiggle Wire  | Tip Adapter  | Shrinking Tip  | Wiggle Wire Tip  |

SAME GREAT TOOL, DIFFERENT NAME

| | | | | | |
|------------------------------|---|--|---|---|---|
| OPTIONAL UPGRADES & REORDERS | Thin Wire  1/2 lb (DF-508) 1 lb (DF-507) | Thick Wire  1/2 lb (DF-508TK) 1 lb (DF-507TK) | 11" Weld Rods  DF-503iiLR | 7" Weld Rods  DF-503iir | Ding Massager  DF-595DM |
|------------------------------|---|--|---|---|---|

HAMMERHEAD STEEL REPAIR STATION



HAMMER HEAD

DF-595ii

Kit Includes:
Wiggle Wire Tip
Shrink * Adapter Tip
1/2 lbs Wiggle Wire
4-Finger Claw
Slide Hammer Rod & Weight
Short Pull Rod
Leverage Puller (DF-595iiLP)
Ground Magnet (DF-GM)

Optional Upgrades:
See Previous Page

| VOLTAGE | BREAKER | WELDING CABLE |
|---------|---------|---------------|
| 110v | 30 amp | 6 ft |

MULTI-HEAD HAMMER SET

DF-HK111

- Quick changing heads
- 9 Interchangeable heads
- 3-head ring hammer included
- Blow molded case
- Simplify your tool box

9

HEADS

MULTIPLE
TOOLS IN ONE



DOOR SKIN PLIERS

DF-DSP310

- Holds the door skin securely in place
- Provides clamping without interrupting flange fold over

2

SPECIALIZED CONTACT PADS

PERFECT FOR
RESKINNING

Inner contact
bar spreads the
force evenly

Outer pad prevents
damage to outer
panel

Adjustable to clamp
onto different panel
thicknesses



FLEXIBLE FENDER PULLER

DF-HD0140

- Hinged hooks pivot
- Shapes to the curve of the fender
- Pulls 1.5 ton
- Pull core supports

1.5

TON

HIGH
QUALITY



RING HAMMER

DF-903

- 3 hammer heads in 1 tool
- Easy to use multi-tool
- Fits into tight spaces
- Solid hit from small tool
- Ultimate utility

3

TOOLS IN ONE

MULTI-
PURPOSE



Spot Weld Bits for Chuck Drill



DF-1786VP Variety Bits
Multi-faceted no slip shank. Variety pack of 5 bits of the hardest coating available! Titanium Carbo-Nitride (HSSE-TiCN) coated drill bits. Includes one 6mm, three 8mm, & one 10mm bit.



DF-1780T Bit 8x80mm
Titanium Nitride Drill Bit
Specifically designed for the rigors of spot weld drilling, German made bits can be used with any 3/8" drill. Centering nib prevents bit from walking.

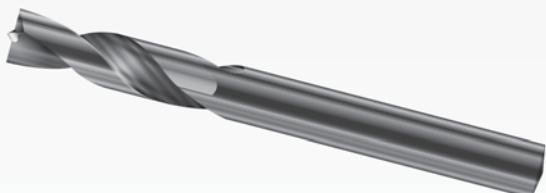

DF-1780 Bit 8x80mm
High Speed Cobalt Drill Bit
Specifically designed for the rigors of spot weld drilling, German made bits can be used with any 3/8" drill. Centering nib prevents bit from walking.

| | | | |
|--------------|--|--|--|
| BORON | | | ▲ DF-1690 8mmx45mm Tungsten-Carbide |
| HARD EDGE | | | ▲ DF-1680TC 8mmx45mm Titanium Carbon Nitride |
| HARD EDGE | | | ▲ DF-1610TC 10mmx45mm Titanium Carbon Nitride |
| HEAT RESIST. | | | ▲ DF-1680T 8mmx45mm Titanium Nitride |
| HEAT RESIST. | | | ▲ DF-1610T 10mmx45mm Titanium Nitride |
| HSS | | | ▲ DF-1465 6.5mmx45mm High-Speed Cobalt |
| HSS | | | ▲ DF-1480 8mmx45mm High-Speed Cobalt |
| HSS | | | ▲ DF-1610 10mmx45mm High-Speed Cobalt |

SPOT ANNIHILATOR SPOT WELD DRILL KIT

SPOT ANNIHILATOR DF-15DX

- Depth Adjustable
- Smart Pressure Valve
- No Slamming
- Prevent bit breakage
- Boron steel capable
- Pneumatic cutting pressure



WARRANTY

1 YEAR

AIR PRESSURE

90 PSI

ROTATIONAL SPEED

1,000 RPM

SHUNTING PLIERS

DF-SP360

- Required by I-CAR for STRSW E-coated panels
- Shunts the current flow
- Thick copper wire and pads
- Ensure proper welds

4
GAUGE WIRE

SAVES THE E-COAT



MAX AMPERAGE

145 AMPS

COPPER WIRE

4 GAUGE

WARRANTY

90 DAYS

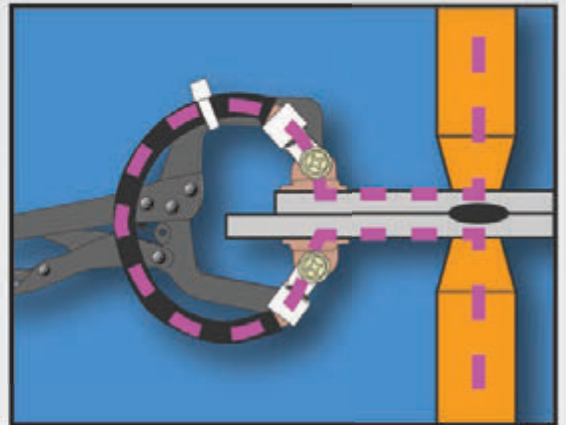

Why Use Shunting Pliers?

Squeeze-type resistance spot welding (STRSW) sometimes requires additional measures, in the form of shunting the current flow, to create a successful spot weld.

Conductive coatings on steel, such as zinc or weld-through primer increase the resistance but a successful weld can be accomplished. Non-conductive coatings on steel, such as E-Coat (a corrosion-resistant primer applied to parts by the manufacturer) inhibit the completion of the spot weld.

The E-Coat on the mating surfaces can be saved when using STRSW with the use of the Dent Fix Shunting Pliers (DF-SP360). Simply remove the coating from only the outside surfaces, position the shunting clamp at the spot weld site, and the spot weld is made at the adjacent site. The current chooses the path of least resistance when confronting the non-conductive E-Coat, the shunting pliers facilitates the electrical current from one side to the other. The E-coat at the mating surface burns away. The process is very quick and despite the fact most of the current flows between the electrode tips the current detour was brief but necessary.

MICRO WELD CLAMPS

DF-MC201

- Generates strong clamping force
- Great low profile
- Secure for pinch and spot welds
- Screw top close to secure
- 4 clamps per pack

4
PIECES

**GENERAL
USE CLAMPS**



| | |
|--------|--------------|
| HEIGHT | WIDEST WIDTH |
| 2.25" | 1.125" |
| DEPTH | NARROW WIDTH |
| 0.5" | 0.75" |

SURGE PROTECTOR

DF-601A

- Protects electronics from surges
- For 12 & 24 volt systems
- Lifetime warranty
- Made in the USA
- DO NOT USE ON HYBRIDS

12 • 24
VOLT SYSTEMS

**LIFETIME
WARRANTY**



RIGHT ANGLE

DF-701

- Compact design
- Works best in tight areas
- Remove thick seam sealer
- Undercoating can be removed
- Decal wheel & 3 coarse brushes



**OFFSET ERASER
WHEEL INCLUDED!**



ORIGINAL
DF-705 Decal Eraser
Softer
Will not burn the paint.
The perfect tool for cleanup
of moldings.



TOUGHER
DF-705D Offset Eraser
More Durable
Perfect for the removal of
large decals such as those
found on delivery vans.



DF-702C Coarse Brush
The flex allows the brushes
to compress in tight corners
and contour themselves over
lipped edges and curved
corners. Makes fast work of
bed liner.

If you don't have one you need one. With the Coarse brush, undercoating and seam sealer are stripped away easily and cleanly, right down to the bare metal. The brushes do not clog up. Remove rust and scale. The fine brush is perfect for getting paint out of tight spaces. The geared Decal Eraser will strip a 2 foot by 2 foot decal in less than 2 minutes with no paint burn. The eraser is ideal for removing the adhesive backing on moldings and badges. The tool carries a year warranty and our guarantee of complete satisfaction.

ELIMINATOR INLINE DECAL & UNDERCOATING REMOVER

ELIMINATOR

INLINE UNDERCOAT AND DECAL REMOVER
DF-700DX



3,500

RPM

Pneumatic Operation

Kit Includes:

- Eliminator Tool (DF-700T)
- Original Decal Eraser (DF-705)
- Offset Decal Eraser (DF-705D)
- Fiber Discs (DF-710BW)
- Single Disc Hub (DF-710BHS)
- Double Disc Hub (DF-710DHS)
- Coarse Brush (DF-702C)
- Fine 23mm Brush (DF-702SF)
- 11mm Coarse (DF-702C11)
- Fine Brush (DF-702F11)
- 23mm Hub (DF-702H23)
- 11mm Hub (DF-702HH)
- Blow Molded Case

| | | |
|--------------------------|---------------------------|--------------------|
| REQUIRED PRESSURE | AIR CONSUMPTION | FREE SPEED |
| 90 PSI (-6 bar) | 4 CFM | 3,500 RPM |
| AIR INLET | REQUIRED HOSE SIZE | TOOL WEIGHT |
| 1/4" NPT | 3/8" ID (9.5mm) | 2.6 lbs (1.2Kg) |



LED Light
DF-LED935

ELIMINATOR
DF-700DX

ALUSPOT MINI
DF-900B

ULTRA DING MASSAGER
DF-DM555UDX

7Z NITROGEN
PLASTIC WELDER
DF-EZN1G



PREMIER AUTO BODY
TOOLS & EQUIPMENT

Since 1979



ALUSPOT DELUXE
DF-900DX

ALUSPOT EXTENDED
DF-900DXE

The MAXI
DF-505/220V



Self-Piercing Riveter
DF-SPR67

Aluminum
Hammer Set
DF-AH714



Lucille



ANGLED FINGER SANDER

DF-FBS20

- Guide keeps grinder in place
- Compact design
- Works best in tight areas
- Body rotates for access



LONG GRINDER

DF-I9315CR

- Reach into corners to grind
- Extra long handle
- Shield rotates left and right
- Fits into tight work spaces
- 6.3 bar, 90 PSI



FINGER SANDER

DF-FBS16

- Gets into tight spaces
- Interchange belt
- Sand down a weld
- Grind rough metal spots
- 328x10mm belt

16,000

RPM

MULTIPLE PURPOSE



RPM

16,000

AIR PRESSURE

90PSI

WARRANTY

1 YEAR

PANEL SAW

DF-PS36

- Set the depth of the cut
- Cut through top panel only
- Double grip handle for firm control
- Guide helps keep the line straight

10,000

RPM

DEPTH ADJUSTABLE



SLOT PLIERS

DF-SP820

- Produces 8x20mm slot punch
- Ideal for MIG brazing
- Throat depth of 30mm
- Comfort grip
- Up to 18 gauge steel
- Online only at DentFix.com



8x20mm

CAR MIG
BRAZING

JAGUAR
PROGRAM

PUNCH/FLANGE

DF-516PF

- Punches 8mm holes
- Up to 18 gauge steel
- Swivel head for flanging
- Also available in 6.5mm holes (DF-316PF)



8mm

ALL HOLE PUNCH DIES ARE ANGLED FOR SHEARING EFFECT



8.0MM PUNCH

DF-516

- Punches 8.0mm holes
- Up to 18 gauge steel
- Depth adjustable
- Long handle for power



8mm

QUALITY
TOOL

6.5MM PUNCH

DF-8

- Punches 6.5mm holes
- Up to 18 gauge steel
- Deep throat
- Allows for more room from edge



6.5mm

TECHNICIAN
FAVORITE

6 IN 1 PUNCH

DF-MP050K

- Punch & Flange Kit
- Pneumatic operation
- 4.0, 5.5, 6.5, & 8.0mm Punch
- 8.0mm Deep Punch/Flange
- Blow molded case

90
PSI

6 TOOLS IN ONE CASE



| |
|--------------|
| FLANGE WIDTH |
| 1 INCH |
| WARRANTY |
| 1 YEAR |





WORKING WITH PLASTIC

4 THINGS TO REMEMBER

The many types of plastic used to construct automotive parts presents special challenges for auto repair facilities when repairing damaged parts. At Dent Fix, we've identified four critical areas of concern to keep in mind when performing plastic repairs. These include:

1. Plastic Types
2. Nitrogen Welding
3. Airless Welding
4. Hot Stapler

1. Plastic Types

Most plastic parts will have the type of plastic that the part is made of stamped on it. Dent Fix plastic rod packages will weld most types of plastics found on an automobile. The following is a list of the plastic welding rod offered and the corresponding stamp that may be found on the part, as well as typical parts that may be made from the type of plastic.

Polypropylene "PP"

PP, PP/EPDM, PP / T20, TPO, TEO, TSOP. Bumper covers, valance panels, headlights, fuse boxes, air intake parts, engine covers, underbody covers, fluid tanks, rocker moldings, fender flares, trim panels, valance panels, case moldings & core supports.

ABS "ABS"

ABS, ABS + PC, ABS + PA. Grilles, cowl grilles, dash bezels, mirror covers, car door handles, trim panels & finish panels.

Polyethylene "PE"

PE, LDPE, HDPE, PPE. Fender liners, splash shields, fluid tanks, & underbody covers.

Polycarbonate "PC"

PC, PC + ABS, PC + PBT. Bumper covers, finish panels, dash parts, core supports, & Saturn door skins

Polyurethane "PUR"

PU, PUR, PRIM, RIM, TPU, TPUR. Bumper covers, rocker moldings, case moldings. These parts are typically found on older or low production vehicles like the Corvette.

2. Nitrogen Welding

Clean the part on both sides with soap and water, sand the inside with 80 grit sand paper on a dual action sander. When welding on the inside of the panel first, it is usually best to leave the outside painted.

Tape the crack together on one side with aluminum tape to hold it while welding.

It is usually best to cut a V groove along the weld run into the part the same width of the rod that you intend to use.

Weld Temp Chart (EZ Nitro Welders)

| | | | |
|---------------|---|---------------|---|
| Polyethylene | 5 | ABS | 5 |
| Polypropylene | 6 | Polycarbonate | 7 |
| Polyurethane | | Not used | |

Direct the heated gas from the nitrogen torch at a 45 degree angle into the corner where the welding rod and part meet heating both the rod and part evenly and equally.

Hold the welding rod approximately 3" from the base, push the rod straight down into the part until it begins to flex. Weld into the heat, pushing straight down on the rod while allowing the rod to roll into the heat. Weld speed should be 4" to 6" per minute.

3. Airless Welding

Some plastics such as polyurethane can only be welded with the airless welder using the rod feed tip.

Clean the part on both sides with soap and water, sand the inside with 80 grit sand paper with a dual action sander. It is usually best to leave the paint on the outside when doing the inside weld, if the first weld will be the inside weld.

Tape the crack together on one side with aluminum tape to hold it while welding.

Cut a tight V groove 60% deep into the part.

Set the temperature to the appropriate tempera-



ture for the plastic being welded.

Weld Temp Chart (EZ Nitro Air Welders)

| | | | |
|---------------|---|---------------|---|
| Polyurethane | 5 | ABS | 5 |
| Polyethylene | 5 | Polycarbonate | 7 |
| Polypropylene | 6 | | |

The temperature should be hot enough to turn the plastic liquid, but not hot enough to cause it to boil

Press the feeder tip onto the part over the V groove. Push the rod through the feeder tip and into the V groove filling the V groove completely.

After filling the V groove with plastic rod use the airless torch to smooth the welded rod by pushing the plastic deeper into the V groove.

Turn over the part and remove the aluminum tape. Cut a tight V groove through the crack exposing a complete strip of the back side welded to allow the front and back welds to commingle.

Smooth the weld with the airless torch. Finish by sanding the weld area with 80 grit paper on a dual action sander.

4. Hot Stapler

Repair thermoplastic parts instead of replacing with a Hot Stapler Kit. This tool heats up a stainless steel staple to be installed in the plastic parts, adding rigidity and restoring integrity.

What Staple to Use

Z-Clip: Stitch Tears (DF-800ZC)

Most versatile. Designed for repairing general tears the Z shape forms a natural stitch. Usually used for small and delicate tears with not much obstructions. This staple is placed at 1 to 1.5 inch intervals on straight breaks and open areas. Tighter staple intervals can be used on curved cracks and high load bearing areas.

N-Clip: High Vibration (DF-800NC)

Some straight cracks might be located in high vibration areas like plastic supports under the hood. To counteract the vibrations, these clips are used because the larger footprint. The extra width covers more surface area and larger footprint allows it to be used horizontally and vertically.

M-Clip: Outside Corner (DF-800MC)

The inside corner of a broken part might not be accessible from the backside. Using the M-Clip on the front of the repair not only allows for the repair to be performed, but also saves time by not having to remove the part from the vehicle. These areas are usually right angles, bends and joints.

V-Clip: Inside Corner (DF-800VC)

A great selection for the inside corners of right angles. The major advantage is to reinforce 90 degree angles

from the inside which also can conceal the repair to the back side. Use smaller intervals to create a stronger spine or connect a support tab.

W-Clip: Grip Corner (DF-800WC)

The specialized W shape really comes handy when a V-Clip will not work. This shape adds extra support to thicker gauge plastic. The ridges provide more stable surface areas for the staple to reinforce the corner. Typical applications are for thick cornered areas and structurally load-bearing joints.

S-Clip: Stitch Holes (DF-800SC)

This staple is a specialty staple that can be used in specific areas like round curves and also in areas where there is little obstruction. When used on open area cracks for best results, after submerging the staple into the plastic give a clockwise twist, about 1/2", while the staple still hot. This twist helps to further reinforce the repair area.

U-Clip: Rounded Corner (DF-800UC)

Another curved application, this staple can help with a rounded corner. This is an alternative to the M-Clip which would leave exposed staple. Also effective in curved areas around screw and plastic rivet holes.

How to Hot Staple

Join the adjacent pieces of the repair area together to restore the original form.

Using the Hot Stapler, heat up the staple and press it gently to set. Apply light, controlled pressure. When pressed too hard it can bend or penetrate through the repair area.

When the StapleClips® is half way through the repair surface, you may give a little twist to the S and Z StapleClips® to lock laterally in the plastic, then release the On/Off Switch button on the grip. Wait for a few seconds until the repaired gets firm. Next, draw the StapleClips® out of the prongs.

When repairing damaged areas with considerable length, please repeat the procedure 2-5 at intervals of 1-3 cm.

With a gloved hand simply snap off the Dent Fix Breakaway® StapleClips®.

Grind off excess or file any remaining staple above the service, using a sander or grinder. Smooth ridges or fill any gaps with the plastic rods and Finishing Iron included in the kit.

Finish as necessary with texture and paint.

EZ NITRO PLASTIC WELDER GENERATOR

No More Tanks

Save Money! Convert shop air into nitrogen to run at a much lower cost than refilling tanks.

The DF-EZN1G EZ Nitro Plastic Welder Generator eliminates the need for refilling nitrogen tanks and has a smaller footprint taking up less space in the shop thanks to its onboard nitrogen generator. The proprietary Flow Adjust Switch Technology

(FAST) system makes the DF-EZN1G the easiest nitrogen welder to learn and use.

CONSUMABLES - See BELOW

110V

POWER

NITROGEN WELDER: 110V
N2 Generator: 90PSI
HEAT GUN: 110V



| | | | | | | |
|--|---|--|--|---|--|---|
| INCLUDED WITH DF-EZN1G EZ Nitrogen Plastic Welder Generator  DF-EZN1-AT150 | Nitrogen Welder  DF-900GHG | Storage Cart  | Plastic Rod Assortment  | Generator  | Heat Gun  DF-900HG | OPTIONAL EQUIPMENT:  Hot Stapler DF-800BR |
| Aluminum Tape  DF-EZN1-AT150 | Heat Gun Holster  DF-900HGH | Hand Seamer  DF-EZN1HS | | | | |

| | | | |
|---|--|---|---|
| EZ NITRO PLASTIC WELDER PLASTIC WELD ROD 25 Piece Pack | POLYETHYLENE PE, LDPE, HDPE, PPE | POLYPROPYLENE PP, PP/EPDM, PP/T20, TPO, TE0, TSOP | POLYCARBONATE PC, PC + ABS, PC + PBT |
| ABS ABS, ABS + PC, ABS + PA | 3mm • Round DF-PEBK03 9mm • Flat DF-PEBK09 15mm • Flat DF-PEBK15 | 3mm • Triangle DF-PPBK03T 3mm • Round DF-PPBK03 6mm • Flat DF-PPBK06 9mm • Flat DF-PPBK09 15mm • Flat DF-PPBK15 | 3mm • Triangle DF-PCNT03T 3mm • Round DF-PCNT03 6mm • Flat DF-PCNT06 9mm • Flat DF-PCNT06 15mm • Flat DF-PCNT15 |
| 3mm • Triangle DF-ABBK03T 3mm • Round DF-ABBK03 9mm • Flat DF-ABBK09 15mm • Flat DF-ABBK15 | POLYURETHANE PU, PUR, PRIM, RIM, TPU, TPUR | | |
| | 3mm • Round DF-PUNT03 | | |



EZ NITRO PLASTIC WELDER GENERATOR

EZ NITRO
PLASTIC WELDER
Generator

High Pressure Nitrogen Outlet can run air tools.



Converts shop air into nitrogen to run the plastic welder



ALSO AVAILABLE BOTTLE-FED UNIT



80 CU FT MAX

DF-EZN1

- Kit Includes:**
- EZ Nitrogen Welder Unit
 - Air Welder
 - Rolling Storage Stand
 - N2 Generator
 - Power Strip on the cart
 - Hand Seaming Tool - 3.5"
 - Aluminum Tape Roll - 150ft
 - Heat Gun Holster
 - Plastic Sample Pack
 - ABS
 - Polycarbonate
 - Polyethylene
 - Polypropylene
 - Polyurethane

NITROGEN PRESSURE

20 PSI

AIR PRESSURE

20 PSI

WEIGHT

54 lbs.

EZ NITRO PLASTIC REPAIR STATION - DXE



Ditch the bottle.

Save yourself from refilling nitrogen bottles! Convert shop air into N2 instead of paying for refills.



F.A.S.T. System

Flow Adjust Switch Technology makes the DF-EZN1G/DXE the easiest nitrogen welder to learn and use. It simplifies nitrogen welding and eliminates flow adjustments by the user.

110V

POWER

N2 Welder

The EZ Nitro DXE is the most comprehensive plastic work station available. All the tools needed bundled in one tight package. From grinders to hot staplers, everything is included to help you profit from the repair of expensive plastic parts. Improve shop efficiency by turning light hit vehicles faster. On board nitrogen generation just makes this a sweeter deal. Everything locks away to protect your investment.

Tool List - See PG 45



PLASTIC REPAIR

COMPARE EZ NITRO REPAIR STATIONS

GAS WELD | AIR WELD | HOT STAPLER | GENERATOR

STOP THROWING AWAY BUMPER COVERS - REPAIR INSTEAD OF REPLACE



EZ BOTTLE FED

DF-EZN1

EZ Nitro Plastic Welder
 Airless Plastic Welder
 Heat Gun (DF-900HG)
 Heat Gun Holster
 Aluminum Tape
 (DF-EZN1-AT150)
 Tank Reglator
 Tank Brackets
 Plastic Welding Rods:
 ABS, Polypropylene,
 Polycarbonate, Polyethylene,
 & Polyurethane
 • Nitrogen Tank not included,
 needs to be locally sourced.

UPGRADE TO NO BOTTLE:
 DF-EZN1G N2 Generator (Pg 46)



EZ NITRO G

DF-EZN1/G

Nitrogen Generator
 EZ Nitro Plastic Welder
 Airless Plastic Welder
 Heat Gun (DF-900HG)
 Heat Gun Holster
 Aluminum Tape
 (DF-EZN1-AT150)
 Plastic Welding Rods:
 ABS, Polypropylene,
 Polycarbonate, Polyethylene,
 & Polyurethane



EXTENDED DXE

DF-EZN1G/DXE

Nitrogen Generator
 EZ Nitro Plastic Welder
 Airless Plastic Welder
 Hot Stapler Kit (DF-800BR)
 Mini Die Grinders
 (DF-DG5227)
 Heat Gun (DF-900HG)
 Double End Nylon Drolley
 (DF-900DEND)
 Round Head Nylon Chisel
 (DF-900RHND)
 Aluminum Tape
 (DF-EZN1-AT150)
 Multi-Clip Pliers (DF-625)
 Plastic Clip Pliers (DF-624CP)
 Clip Lifter (DF-618CL)
 Hand Seamer (DF-EZN1HS)
 Ring Hammer (DF-903)
 Dust Cover
 Utility Wedge Set (DF-609)
 Plastic Lever Scraper
 (DF-WK20)
 Plastic Welding Rods:
 ABS, Polypropylene,
 Polycarbonate, Polyethylene,
 & Polyurethane



CONSUMABLES - PG 42 & 48

EZ NITRO GENERATOR

DF-EZG1

Upgrade any brand of Plastic Welder with the EZ Nitro Generator and "Ditch the Bottle", Never Run out of Nitrogen AGAIN! Dent Fix's revolutionary Dual Chamber Separating System transforms your compressed shop air into an endless supply of both regulated & high pressure nitrogen. BONUS: You can also fill your customer's tires with beneficial nitrogen and/or safeguard the internals of your pneumatic tools by powering them with nitrogen from the EZ Nitro Generator!



UPGRADE YOUR BOTTLE-FED WELDER!



HOT AIR WELDER

DF-EZA1

Simply plug into a 110V socket and begin welding damaged plastic parts back together! Adjustable heat setting for multiple plastic types. Includes plastic welding rod samples, smoothing tip, and feeder tip.



MINI DIE GRINDER

DF-DG5227

Compact design fits perfectly into the hand and the cushioned grip allows for long hours and less vibration. The adjustable air speed and whisper quiet operation make this the perfect grinder.

-  1/2" Round Carbide Burr (DF-CB05)
-  3/8" Tapered Carbide Burr (DF-CB03)
-  1/8" Straight Carbide Burr (DF-CB12)



HAND SEAMER

DF-EZN1HS

Wide flat nose is perfect for forming plastic lips, tabs, and flanges when performing plastic repair. Heavy duty solid construction.



Upgrade your Tank Nitrogen Welder Never run out of Nitrogen



SAVE MONEY & LIMIT DELAYS
Convert shop air into N2 instead of paying for refills



AWARD WINNING INNOVATION
Dual Chamber Generator for On-Demand N2



AVOID SAFETY CONCERNS
Ditch the risks of managing tanks

EZ NITRO
Generator
UPGRADE KIT | DF-EZG1



HOT STAPLES / PATCH MESH



DF-800WC/50 (50 pc)
DF-800WC/250 (250 pc)



DF-800ZC/50 (50 pc)
DF-800ZC/250 (250 pc)



DF-800MC/50 (50 pc)
DF-800MC/250 (250 pc)

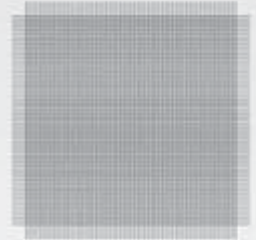

Patch Mesh
DF-800PM



DF-800NC/50 (50 pc)
DF-800NC/250 (250 pc)



DF-800SC/50 (50 pc)
DF-800SC/250 (250 pc)



DF-800UC/50 (50 pc)
DF-800UC/250 (250 pc)



DF-800VC/50 (50 pc)
DF-800VC/250 (250 pc)

HOT STAPLER DELUXE

DF-800BR



Kit Includes:
Hot Stapler
Finishing Iron (DF-800SI)
x50 U-Clip (DF-800UC/50)
x50 S-Clip (DF-800SC/50)
x50 V-Clip (DF-800VC/50)
x50 M-Clip (DF-800MC/50)
x50 Z-Clip (DF-800ZC/50)
x50 W-Clip (DF-800WC/50)
x50 N-Clip (DF-800NC/50)
Blow Molded Case

THE ORIGINAL HOT STAPLER
MADE IN AMERICA



110V
VOLT

- Installs staples to repair tears in plastic
- Saves thermoplastic parts from the trash
- Crafted to be compact & lightweight
- No base station

| VOLTAGE | WEIGHT |
|---------|----------|
| 110v | 5 lbs |
| MADE IN | WARRANTY |
| USA | 5 YEARS |



PLASTIC REPAIR

LI-ION BATTERY HOT STAPLER DF-600BR

Three functions in one

- Install hot staples, airless weld plastic, and smoothing iron.
- Hand held unit is small in stature but very capable in tight spaces
- Foam inserts included with the case



Kit Includes:

Main Unit, Hot Stapler Head, Iron Head, Air Welder Head, Plastic Rod Samples, Staple Samples, Patch Mesh, and case with foam insert



3 TOOLS
IN ONE

RECHARGEABLE
BATTERY

HOT STAPLER BASIC DF-400BR



Kit Includes:

Hot Stapler
x50 S-Clip StapleClips (DF-800SC/50)
x50 V-Clip StapleClips (DF-800VC/50)
x50 M-Clip StapleClips (DF-800MC/50)
x50 Z-Clip StapleClips (DF-800ZC/50)

VALUABLE
TOOL

110V
VOLT

- Installs staples to repair tears in plastic
- Saves thermoplastic parts from the trash
- 3 heat settings: Light Duty, Regular, HD
- Handle + base station

| | |
|---------|----------|
| VOLTAGE | WEIGHT |
| 110v | 6 lbs |
| MADE IN | WARRANTY |
| TAIWAN | 1 YEAR |

MULTI-CLIP PLIERS

DF-625

Multiple tools in the palm of your hand

- Remove, pry, or cut tabs
- Disassemble clips
- Also cuts tubing or zip ties



WEDGE SET

DF-609

- Utility wedge set
- Use for door wedges
- Great for molding removal
- Solid plastic construction
- 30 & 60mm wedges
- One clip tool



3-PIECE
MOLDING
REMOVAL

WEDGE LIFTER

DF-WK20

- Perfect for glass removal
- Also use as a door wedge
- Molding removal made simple
- Great for around air vents



3PC CLIP SET DF-618XL

- Removes fasteners & clips
- Great for upholstery removal
- Disassemble door panels
- 245x11, 370x11, 250x5mm



FOAM STORAGE FOR
TOOL DRAWERS

5PC CLIP KIT DF-618LK

- For plastic fasteners & clips
- Used for upholstery removal
- Door panel removal
- Angled & curved for leveraging



PERFECT TO DROP
IN A TOOL BOX

COMBI WEDGE DF-619

- Wedge plus clip removal tool
- For dash & door panel removal
- Hard to lose, hi-vis yellow
- Constructed of strong plastic
- Pivot point for prying
- Length: 8.5"



2 TOOLS
IN-ONE

WEDGE + CLIP
REMOVER

CLIP LIFTER DF-618CL

- Safely remove clips & fasteners
- Reduce fragile parts breakage
- For upholstery & door panels
- Hi-vis yellow handle
- Sturdy construction
- Length: 6.9"



LENGTH:
6.9"

DELUXE TRIM SCRAPER SET

DF-623TPS

- Safely remove interior & exterior trim pieces
- Velcro enclosed canvas pouch
- Remove air vents, door trim, dashboard pieces, plastic trunk guards, or any delicate pieces
- Ninja Warrior Set



TRIM PANEL SET

DF-621TPS



PROFESSIONAL TOOL SET

12
PIECES

- Trim panel popper set
- Two pry bars
- Nine double-sided clip removers
- Double-sided dead blow hammer
- Blow molded hard case
- Detail Set





27
PIECES

TRIM PANEL SCRAPER SET
DF-620TPS

SAVE DELICATE PARTS

12
PIECES



- Easily save delicate trim pieces
- Includes metal pry bar
- Store in canvas pouch with Velcro enclosures
- Tradesman Set



SUCTION GUN

DF-SG70

- Safely remove head/tail lights and glass-like surfaces
- Hold windows in place while working on window regulators
- Quick release button



REMOVE SNUG PARTS,
LESS BREAKAGE

SENSOR HOLE PUNCH

DF-EZ10

- Precise and clean way to create holes
- Cut holes in plastic bumpers up to 5mm in thickness
- Will not damage the paint



Holes Sizes (mm):
17, 18, 18.2, 19,
20, 22.5, 24,
26, 26.7,
& 32.



SWIVEL RIVETER

DF-CT888

- Install difficult to access plastic rivets
- 360° rotational head
- Includes 5.0 & 6.3mm rivets



CONSUMABLES
PLASTIC RIVETS

5.0mm (50 pc) DF-CT887RS
6.3mm (50 pc) DF-CT887RL

SLIMLINE RIVETER

DF-CT887

- Install difficult plastic rivets
- 2" gap clearance
- Works around wheel arches
- Includes 5.0 & 6.3mm rivets



CONSUMABLES
PLASTIC RIVETS

5.0mm (50 pc) DF-CT887RS
6.3mm (50 pc) DF-CT887RL



BLOW MOLDED
CASE INCLUDED



PLASTIC REPAIR

STATIC ZAP

STATIC ELIMINATION TOOL



STATICZAP

DF-EZAP

- Neutralizes the static charge
- Eliminates dust attraction
- Metallic sparkle will stand out
- Easy to use, just hook up to air hose and go
- Lithium ion battery powered

The StaticZap incorporates the efficiency and power of an air amplifier with the proven technology of corona ionization to produce a highly effective anti-static blow-off gun.

Perform the anti-static blow off before starting and at every stage in the painting process to produce a finish that looks like glass. Using this tool cuts down the time needed for wet sanding and buffing, saving labor on post work.

REPLACEMENT PARTS:

- Emitter Pins (5 pc) | DF-ZAP01
- Filter Kit (1 pc) | DF-ZAP02



NEUTRALIZE THE STATIC CHARGE ELIMINATING DUST ATTRACTION

GREAT FOR WINDOW TINTING & VEHICLE WRAPS

CORONA IONIZATION TECHNOLOGY

- Kit includes:
- Lightweight Durable Gun
 - Rechargeable Lithium Ion Battery
 - Two Emitter Pins
 - Safety Keys
 - Storage Case

ULTRA DING MASSAGER DF-DM555UDX

- Dings, dents, & hail damage
- Easy to use & learn
- Special nibs for crease repair
- Improved kit with everything
- Works on steel or aluminum
- Use on OEM paint only

Kit Includes:

- x24 Assorted Pulling Nibs (DF-DM15)
- x12 Glue Sticks (DF-DM520GS)
- 120v Glue Gun (DF-DM530GG)
- Knockdown Tool (DF-KDTE)
- Round Knockdown Tip (DF-KDRT)
- Pointed Knockdown Tip (DF-KDPT)
- Squeeze Puller (DF-DM540SP)
- Slide Hammer (DF-DM530SH)
- T-Puller (DF-TPG)
- Shaping Tools
- Plastic Scraper Stick (DF-WK30)
- Release Agent (DF-DM520RA)
- Blow Molded Case

Optional Upgrades:

- High Strength Glue (DF-HS10)
- Prof. Strength Glue (DF-PG10)



PDR NIBS (10 pc)

| SHAPE TEXTURE | SIZE | PART # | SHAPE TEXTURE | SIZE | PART # |
|-----------------|---------|-----------|--------------------|---------|-----------|
| Round Ridge | 15mm | DF-DM15FR | Oval Ridge | 49x33mm | DF-DM49RO |
| Round Ridge | 20mm | DF-DM20FR | Oval Dimples | 30x20mm | DF-DM30DO |
| Round Ridge | 25mm | DF-DM25FR | Oval Dimples | 39x25mm | DF-DM39DO |
| Round Ridge | 32mm | DF-DM32FR | Oval Pimple | 34x23mm | DF-DM34PO |
| Round Ridge | 36mm | DF-DM36FR | Oval Pimple | 40x28mm | DF-DM40PO |
| Round Ridge | 41mm | DF-DM41FR | Rectangle Ridge | 35x24mm | DF-DM35RR |
| Round Pimple | 32mm | DF-DM32FP | Rectangle Ridge | 49x33mm | DF-DM49RR |
| Round Pimple | 36mm | DF-DM36FP | Rectangle Pimple | 30x20mm | DF-DM30PR |
| Round Pimple | 41mm | DF-DM41FP | Rectangle Lines | 32x17mm | DF-DM32RL |
| Round Dimple | 16mm | DF-DM16FD | | | |
| Round Dimple | 21mm | DF-DM21RD | | | |
| Round Dimple | 26mm | DF-DM26RD | | | |
| Oval Spine | 33x23mm | DF-DM33SO | | | |
| Oval Spine | 40x28mm | DF-DM40SO | | | |
| Oval Spine | 48x33mm | DF-DM48SO | | | |

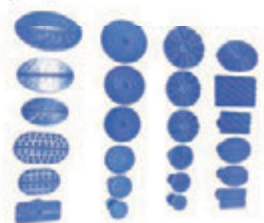

Variety Pack
(24 Piece)
DF-DM24VP



GLUE PULLER XTREME DF-GPX

- Fix major dents with no heat input
- Critical for repairing heat sensitive materials
- Save time by avoiding welding/arc procedures
- Repair without damaging undercoating



Kit Includes:
Ringed Pulling Pads (1-5 Ringed)
Knockdown Tool with 4 Heads
Pulling Rig with 3 bars
Plastic Scraper Stick (DF-WK30)
Release Agent
Glue Gun
Glue Samples
Blow Molded Case

Optional Upgrades:
High Strength Glue (DF-HS10)
Prof. Strength Glue (DF-PG10)

33PC PDR ROD KIT

DF-PDRKIT33

- Professionally crafted PDR rods and hangers
- Essential gathering of expertly designed pieces
- Access the back of the panel with ease
- Duffle bag case

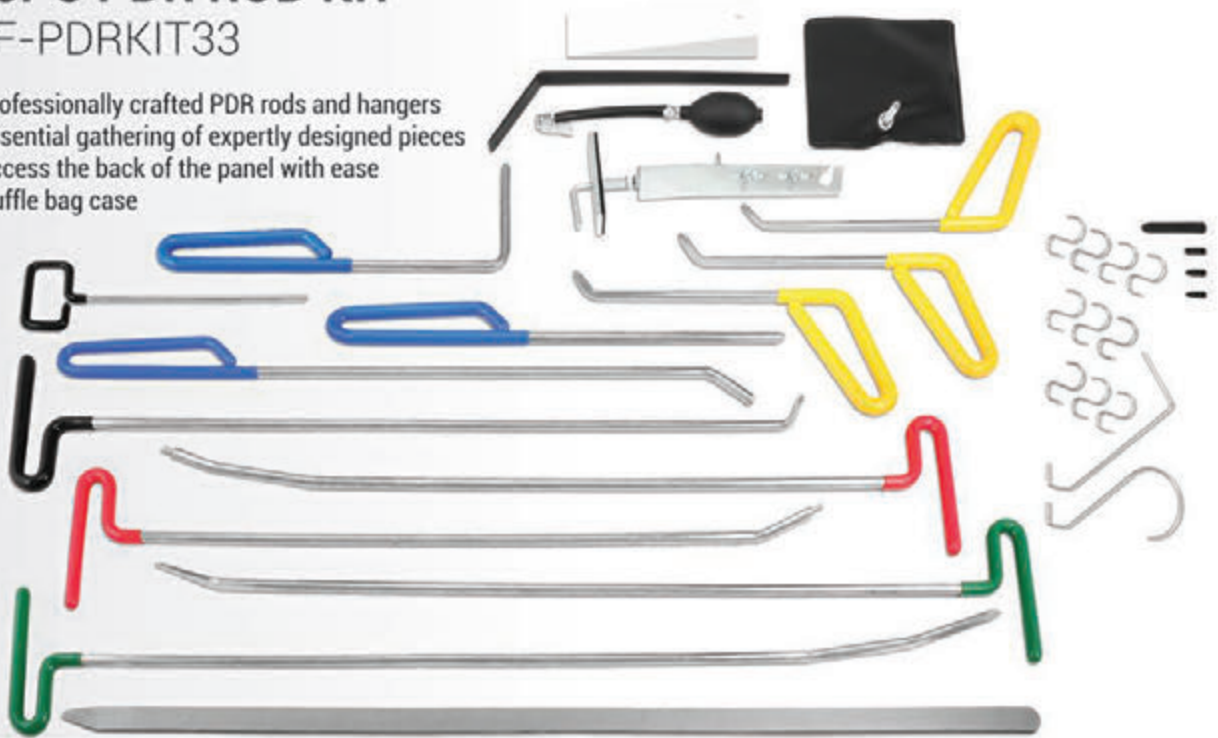

DING ENHANCER SHIELD

DF-DM55DE

From body shop estimating to dealer service check-ins, document the damage by highlighting the dings.

- Sturdy grab handle
- Large 31" diameter
- Collapsible with storage bag

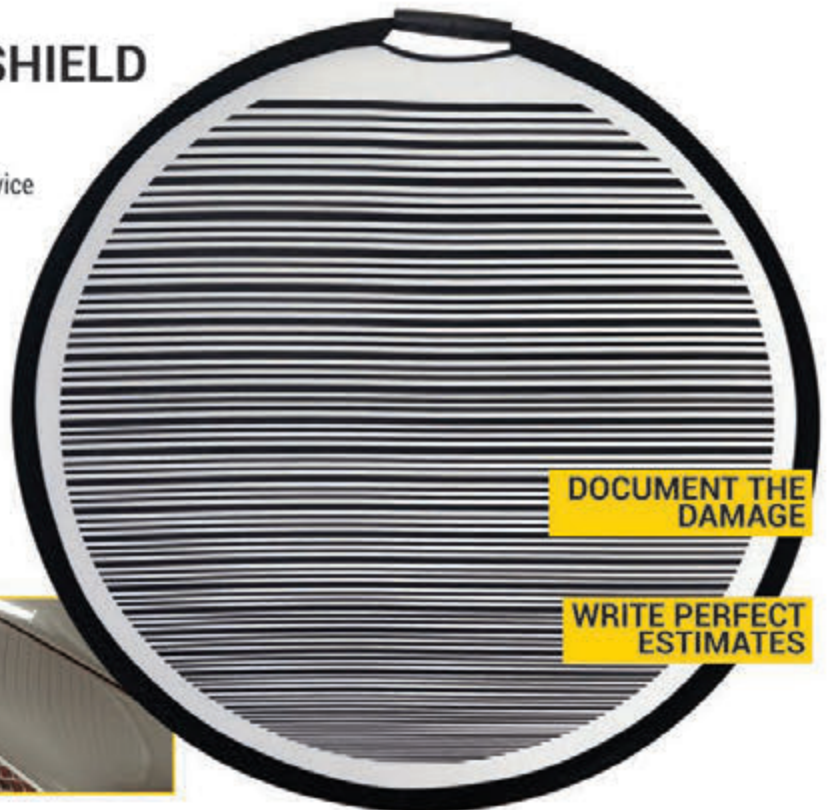

DOCUMENT THE DAMAGE

WRITE PERFECT ESTIMATES



8PC PDR ROD KIT DF-PDRKIT8

- Great introductory set of PDR tools
- All basic tools needed to start working
- Case zips up for easy transportation



**CASE FOR
MOBILE TECHS**

DEAD BLOW HAMMER KIT DF-DB79K

- Gently knock down high spots
- Remove glue residue with the wedge end
- Include case to store hammer & tips
- Option: Hammer Only # DF-DB69



**GREAT FOR
PDR WORK**

**SIX TIPS
INTERCHANGABLE**



BRASS

BRASS

PLASTIC

RUBBER

ALUMINUM

STEEL



DIGITAL TRAM GAUGE DF-3DX

- Easy read digital display
- Measures in metric or American standard
- Measures from 1'4" to 11'11"

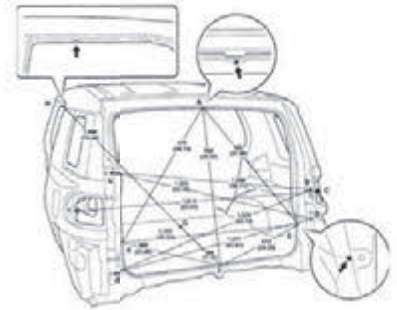

AUTOMATIC SELF CALIBRATING
EXTREMELY ACCURATE
LONG MEASURING RANGE

SWISS TRAM DF-3



HIGHLY
ACCURATE

10'6"
MAX

- Accurate to +/- 1.0mm
- Easy to read tape measure
- Measures 3' to 10'6"

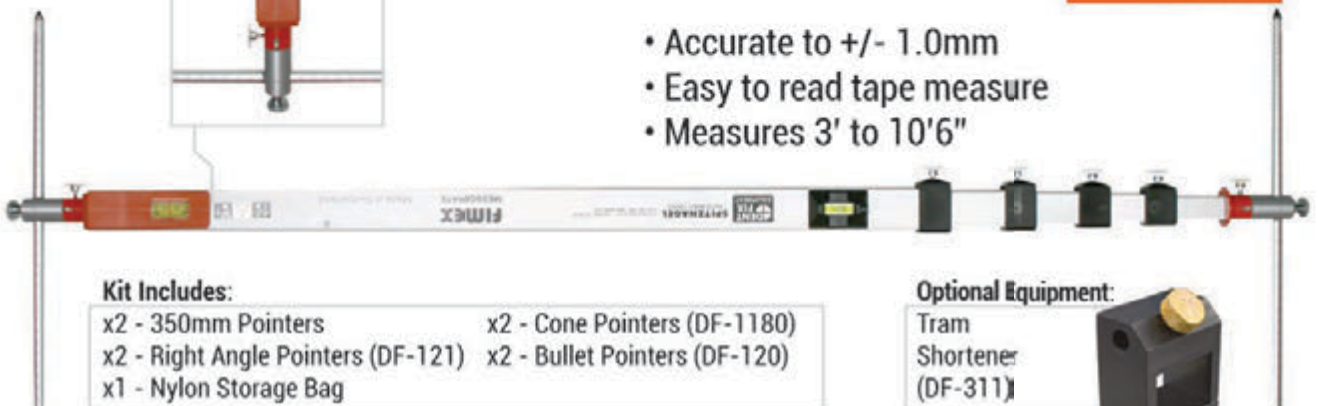

Kit Includes:

- | | |
|------------------------------------|-------------------------------|
| x2 - 350mm Pointers | x2 - Cone Pointers (DF-1180) |
| x2 - Right Angle Pointers (DF-121) | x2 - Bullet Pointers (DF-120) |
| x1 - Nylon Storage Bag | |

Optional Equipment:

- Tram Shortener (DF-311)





Digital Display: Easy to read LCD screen vividly shows measurement readouts. Measures in both metric and American standard

- Kit Includes:
- x3 - 350mm Pointers (DF-301)
 - x2 - 110mm Pointers (DF-302)
 - x2 - Cone Pointers
 - x2 - Bullet Pointers
 - x2 - Pointer Holders
 - x4 - AA Batteries
 - x1 - Blow Molded Case
- Optional Equipment:
- 700mm Pointers (DF-309)

11' 11"
MAX

MINI TRAM DF-3S

MINI & HIGHLY
ACCURATE

3'3"
MAX

- Accurate to +/- 1.0mm
- Easy to read tape measure
- Measures 16.5" to 3'3"

- Kit Includes:
- x2 - 350mm Pointers
 - x2 - Cone Pointers (DF-1180)
 - x2 - Right Angle Pointers (DF-121)
 - x2 - Bullet Pointers (DF-120)
 - x1 - Nylon Storage Bag



Our Swiss Trams are the most durable and accurate

5 METER TRAM

DF-3TC5A



VALUE ADDED TRAM

5
METER

- Easy read widow display
- Includes nylon storage bag
- Measures 3'6" to 15'4"



Kit Includes:
x2 - 350mm Pointers
x1 - Nylon Bag
Optional Equipment:
110mm Pointers (DF-302)

SELF CENTERING TIPS

DF-3TCAS



POINTERS ARE SELF CENTERING

8
PIECE KIT

- No more second guessing when centering
- Higher accuracy when measuring
- Upgrade for DF-3TC3A & DF-3TC5A



MORE ACCURATE MEASUREMENTS

Kit Includes:
x2 Cone Adapters
x2 Small Bolt Adapters
x2 Large Bolt Adapters
x2 Extension Bars
Foam Drawer Insert



3 METER TRAM DF-3TC3A

GREAT FOR ESTIMATES

3
METER

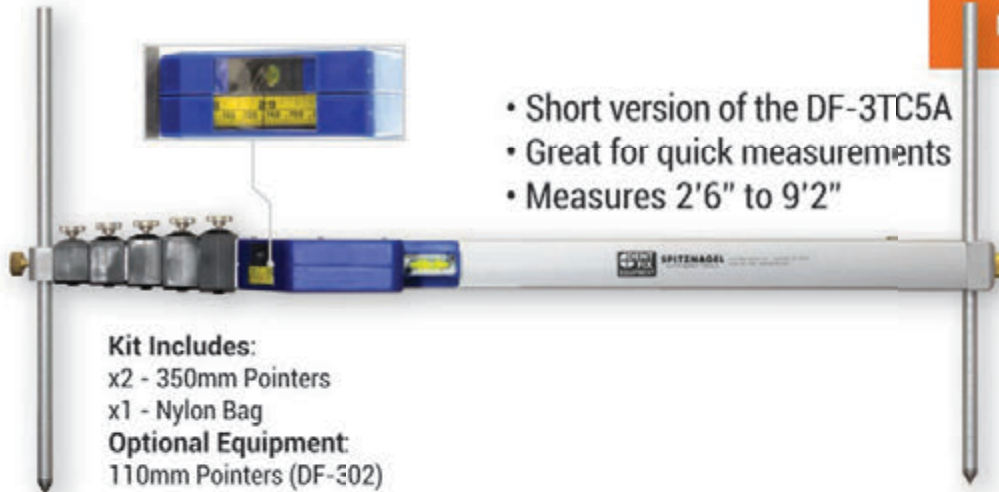

- Short version of the DF-3TC5A
- Great for quick measurements
- Measures 2'6" to 9'2"

Kit Includes:
x2 - 350mm Pointers
x1 - Nylon Bag
Optional Equipment:
110mm Pointers (DF-302)

PERFECT GAP GAUGE DF-PG213

- Eliminates the guess work
- Sets the gap width to factory specifications
- 1 to 10mm (1mm per spacer, 10 total)



SET OF 2
INCLUDED

SET EXACT
FENDER GAP

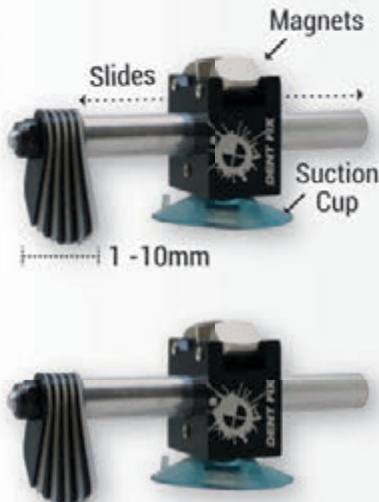

BODYLINE TOOL DF-BL10A

- Re-create fender curve lines perfectly
- Made in the USA



TRACE PERFECT
FENDER LINE

Trace block is
adjustable up
and down



FLEX-O-LIGHT DF-LED110

- Bright light with multiple mounting options
- Illuminate the out of sight areas
- 1 Year warranty

CLAMP, STICK, OR HANG IT



CLAMP IT - To Edge of a workbench



STICK IT - On any ferrous metal surface



HANG IT - Anywhere

STRETCH IT - Up to 22.64"

Standard 9.8" (250mm)



Stretched 22.64" (575mm)



Beam Distance

262.5" (80m)



Impact Resistance

3.28" (1m)



110 LUMENS

Light Output



8h

Run Time

Adjustable Clamp

MAGNETIC LED LIGHT DF-LED935

- Super bright COB (Chip on board) LED
- Hang the lamp by the magnetic swivel base
- Adjustable dimmer switch



USB RECHARGE

935 LUX



| | |
|-----------|-------------|
| MAX HOURS | CHARGE TIME |
| 12 | 4 HOURS |
| MAX LUX | BATTERY |
| 935 | LI-ION |



LIGHTS

MAGNETIC CLAMP

DF-PC203

- Strong & fast way to secure parts
- For a controlled spray painting/coating
- Magnetic base & powerful wedge grip



SUSPENDS THE OBJECT



ALSO AVAILABLE FLEXIBLE UNIT



FLEXIBLE NECK

DF-FC205

DOOR PROP STICK

DF-DPS1

- Secures a door, hatch, or hood in one position
- Three adjustments settings (11", 13", 15")
- Good for left or right use



WORKS GREAT FOR PDR



TORNADOR BLACK

DF-Z020



TURBO CHARGED

3,600

RPM

- Double the power of the Tornador Classic
- Low wear and maintenance
- Feature & Benefit

AIR PRESSURE

5.2-6.4 CFM @ 90PSI

AIR INLET

1/4"

FREE SPEED RPM

3,600

WEIGHT (DRY)

1.34 lbs

TORNADOR CLASSIC

DF-Z010



ADD LIQUID CLEANERS

90

PSI

- Pulse cleaning gun with reservoir
 - Excellent for soft surface cleaning
 - Efficiently delivers additives in a fine mist
- ALSO AVAILABLE: WITH BRUSH (DF-Z010B)**

AIR PRESSURE

5.2-6.4 CFM @ 90PSI

AIR INLET

1/4"

JAR CAPACITY

32 oz

WEIGHT (DRY)

1.34 lbs



TORNADOR BLOW OUT TOOL

DF-Z014



PULSE CLEANING

70

PSI

- Pulsation of air will beat the dirt out
- Durable alloy construction
- Patented tube provides tornador action

AIR PRESSURE

5.2-6.4 CFM @ 70PSI

AIR INLET

1/4"

FREE SPEED

3,600

WEIGHT

15 oz

FOAM GUN

DF-Z011



INSTANT FOAM

32

OZ JAR

- Generates suds for gentle application
- Complete coverage with limited waste
- High density foamer tips add control

AIR PRESSURE

5.2-6.4 CFM @ 90PSI

AIR INLET

1/4"

LIQUID CONSUMPTION

@70 PSI 1 min: 32 oz

WEIGHT

2 lbs (0.90 kgs)