



## **A/C Compressor Assembly With Magnetic Clutch Removal and Installation Instructions**

Prior to the installation of this DENSO First Time Fit® A/C compressor assembly with magnetic clutch, you must read these instructions completely.

---

### **Definition of Terms**

- ⚠WARNING:** Describes precautions that should be observed in order to prevent injury or death to the user during installation.
- ⚠CAUTION:** Describes precautions that should be observed in order to prevent damage to the vehicle or its components, which may occur during installation if sufficient care is not taken.
- NOTE:** Provides additional information that facilitates installation work.
- 

### **General Service Information and Requirements**

**⚠CAUTION:** Only trained/certified personnel who have a thorough knowledge of automotive air conditioning systems should perform repairs to the air conditioning system. In addition, only personnel trained in an approved refrigerant-handling program may recover refrigerant from and charge refrigerant to an automotive air conditioning system

**⚠CAUTION:** DENSO compressors are sealed, pressurized and contain factory-specified amounts of refrigerant oil used in the original design of the unit.

### **REQUIRED TOOLS**

- Safety Goggles
- Assorted Hand Tools
- Refrigerant Recovery Machine for specific (R-12/R134a) refrigerant
- Charging Station / A/C Manifold Gauge Set for specific (R12/R134a) refrigerant
- Vacuum Pump for specific (R12/R134a) refrigerant
- Electronic Leak Detector
- Torque wrench
- Belt Tension Gauge
- Refrigerant Identifier (recommended)

## **SAFETY PRECAUTIONS**

**⚠WARNING:** It has been determined that mixtures of R134a and air can result in combustion when exposed to an ignition source. Shop air should not be used for leak checking.

- Always wear safety goggles.
- Avoid skin contact with refrigerant or refrigerant oil.
- Work in a well-ventilated area.
- Never release refrigerant into the atmosphere.
- Never expose refrigerant containers to direct heat or temperature in excess of 125°F.
- Never expose refrigerant to an open flame.

## **Compressor Removal**

**NOTE:** For more detailed instructions please refer to the vehicle manufacturer's service manual.

- A) Identify the type of refrigerant before working on the vehicle.
- B) Using a certified refrigerant recovery machine, reclaim the refrigerant in accordance with any federal, state or local regulations from the A/C system.
- C) Disconnect the negative (ground) cable from the battery.
- D) Disconnect the A/C compressor lead wire from the vehicle harness.
- E) Disconnect the hoses or hose assembly from the compressor and quickly cap the hose to reduce the amount of moisture entering the A/C system.
- F) Loosen and remove the compressor drive belt.
- G) Loosen and remove the compressor mounting bolts.
- H) Remove the compressor.

## **Compressor Installation**

**NOTE:** For more detailed instructions please refer to the vehicle manufacturer's service manual or service bulletins.

**NOTE:** In the case of A/C system contamination, additional A/C system components may require replacement such as receiver driers, accumulators, expansion devices and certain condenser designs.

**NOTE:** DENSO strongly recommends the replacement of the receiver drier or accumulator when the A/C system has been opened and exposed to atmospheric conditions during the repair process.

**NOTE:** To prevent possible debris from entering the compressor, you may install an in-line filter in the suction line near the compressor. To prevent possible debris from entering the expansion device, you may install an in-line filter.

**NOTE:** The compressor contains a complete 'system' charge of refrigerant lubricant however you must compare the level of compressor lubricant between the new compressor and the compressor being replaced.

- A) Place the compressor on a flat surface, hand turn the clutch pressure plate a minimum of ten (10) times to release lubricant from the compressor head.

**⚠CAUTION:** For compressors with crankcase bolts, the oil must be removed and installed through the crankcase bolt hole. All other compressors can have the oil removed from the discharge port and added through the suction port.

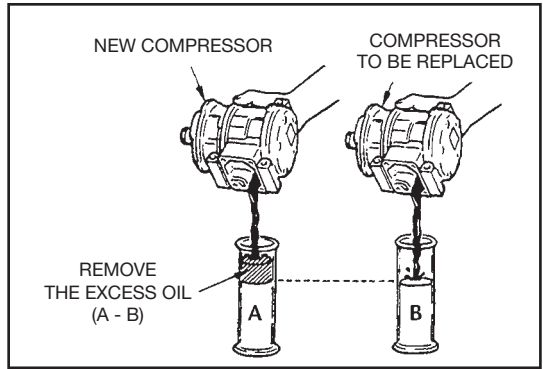

- B) Install the compressor to the engine and or engine bracket.
- C) Tighten and torque the compressor mounting bolts. Refer to the vehicle manufacturer's service manual for correct bolt tightening sequence and torque.
- D) Install and tighten the compressor drive belt. Refer to the vehicle manufacturer's service manual for proper belt tension.
- E) Using the proper refrigerant oil, lubricate and install the new piping o-rings and/or seals (if provided) onto the hoses or hose assembly being installed on the compressor.

**⚠CAUTION:** Refer to the vehicle manufacturer's service manual for proper refrigerant oil.

- F) Connect and torque the hoses or hose assembly to the compressor. Refer to the vehicle manufacturer's service manual for proper torque.
- G) Connect the A/C compressor lead wire from the vehicle harness.
- H) Connect the negative (ground) cable to the battery.
- I) Evacuate and recharge A/C system:
- Protect eyes and skin during recharging by using safety glasses and appropriate hand wear.
  - Connect manifold gauge set and vacuum pump or refrigerant charging station and evacuate A/C system for a minimum of 30 minutes at 61-69 cmHG (24-27 inHG) of vacuum.
  - Refer to the vehicle manufacturer's service manual and charge with the proper refrigerant charge.
  - Use the appropriate electronic leak detector to check the compressor and hose connections for leaks.

**⚠CAUTION:** DO NOT overcharge the A/C system.