



Cabin Air Filter

Removal & Installation Instructions

To maintain air conditioning efficiency, replace the air filter according to the manufacturer's maintenance schedule.

Always use an air filter. Removing the filter may decrease system performance by allowing dust to lower the efficiency of A/C and heating system components.

Prior to the installation of this DENSO First Time Fit® Cabin Air Filter, you must read these instructions completely.

Definition of Terms

⚠WARNING: Describes precautions that should be observed in order to prevent injury or death to the user during installation.

⚠CAUTION: Describes precautions that should be observed in order to prevent damage to the vehicle or its components, which may occur during installation if sufficient care is not taken.

NOTE: Provides additional information that facilitates installation work.

General Service Information and Requirements

⚠WARNING: To prevent the Supplemental Restraint System (SRS, Air Bag System) from operating, remove the ground (negative) cable from the battery, then wait at least 90 seconds before starting this procedure. This allows the backup power system to discharge.

NOTE: For more detailed instructions please refer to the vehicle manufacturer's service manual.

REQUIRED TOOLS:

- Safety Goggles
- Assorted Hand Tools

SAFETY PRECAUTIONS:

- Always wear safety goggles

Cabin Air Filter Removal

The information below explains necessary procedures and tools to remove and install the Cabin Air Filter (CAF).

1. Open the glove compartment and then remove it.
2. Remove the glove compartment support and carefully trim the support as shown. (See Fig. 1)

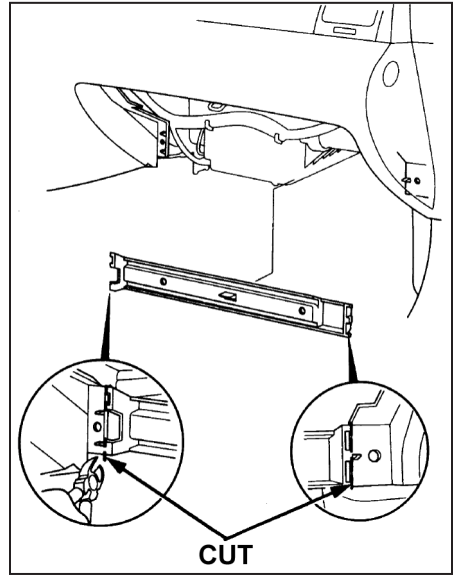

Fig. 1

3. Remove the CAF access lid from the evaporator housing.
4. Remove the original lower CAF assembly and then the upper CAF assembly from the evaporator housing. (See Fig. 2)

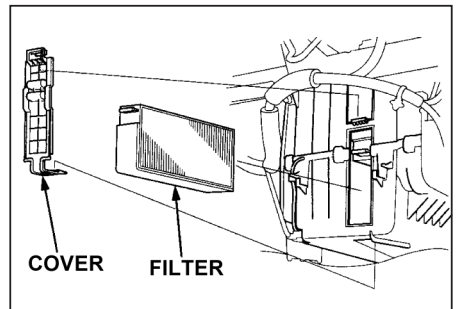

Fig. 2

Cabin Air Filter Installation

5. Remove the original CAF elements from the filter housings. The original filter elements can be discarded and then install the replacement CAF elements into the filter housings. (See Fig. 3)
6. Reinstall the upper filter housing and then the lower filter housing into the evaporator housing.
7. Reinstall the glove compartment and then close it.
8. Reinstall the CAF access lid from the evaporator housing.
9. Reinstall the glove compartment support and then the glove compartment. Close the glove compartment.

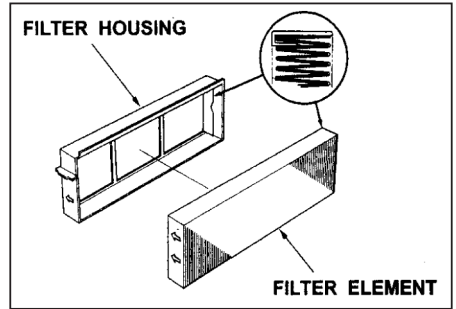

Fig. 3

Noise Test

10. Reconnect the battery ground cable.
11. Engine ON, A/C ON, blower speed on high.
12. Listen for any abnormal air noises from the air filter area.