



A/C Condenser Removal and Installation Instructions

Prior to the installation of this DENSO First Time Fit® A/C condenser, you must read these instructions completely.

Definition of Terms

- ⚠WARNING:** Describes precautions that should be observed in order to prevent injury or death to the user during installation.
- ⚠CAUTION:** Describes precautions that should be observed in order to prevent damage to the vehicle or its components, which may occur during installation if sufficient care is not taken.
- NOTE:** Provides additional information that facilitates installation work.
-

General Service Information and Requirements

⚠CAUTION: Only trained personnel who have a thorough knowledge of automotive air-conditioning systems, the proper tools and an appropriate workspace should perform repairs to a vehicle air-conditioning system. In addition, only personnel trained in an approved refrigerant-handling program may recover refrigerant from and charge refrigerant to an automotive air-conditioning system.

NOTE: DENSO strongly recommends the replacement of the receiver-drier or accumulator when the A/C system has been opened and exposed to atmospheric conditions during the repair process.

REQUIRED TOOLS:

- Safety Goggles
- Assorted Hand Tools
- Refrigerant Recovery Machine
- Charging Station / A/C Manifold Gauge Set
- Vacuum Pump
- Electronic Leak Detector
- Torque Wrench
- Refrigerant Identifier

SAFETY PRECAUTIONS

⚠WARNING: Tests under controlled conditions have indicated that some refrigerants can result in combustion when exposed to an ignition source. Shop air should not be used for leak checking.

Follow the following precautions whenever working on the A/C system. Injury or death may occur if these specific precautions are not followed:

- Always wear safety goggles.
- Avoid skin contact with refrigerant or refrigerant oil.
- Work in a well-ventilated area.
- Never release refrigerant into the atmosphere.
- Never expose refrigerant containers to direct heat or temperature in excess of 125°F.
- Never expose refrigerant to an open flame.

NOTE: Do not remove protective caps from the A/C condenser until the lines are ready to install. Some condensers may contain desiccant. If left uncapped for a long time, the desiccant may absorb moisture and limit its longevity.

A/C Condenser Removal

The information below explains the necessary procedures and tools to remove and install an A/C condenser.

NOTE: For more detailed instructions, please refer to the manufacturer's vehicle service manual. Bolts, where specified, must be torqued to the proper specification. If torque is not specified please refer to the vehicle manufacturer's service manual. On some vehicles, you may have to temporarily remove the radiator support, center hood lock brace and/or a refrigerant line that crosses in front of the condenser.

1. Use a refrigerant identifier to verify the type of refrigerant in the system.
2. Connect the appropriate refrigerant charging station to the A/C system and recover any refrigerant in the system.
3. Disconnect the refrigerant lines from the condenser as follows:

NOTE: On some vehicles, the receiver-drier is secured to the condenser with a holder and a small refrigerant tube links the drier and condenser. These components can be removed as an assembly. For such applications, you can disconnect the line from the outlet of the receiver-drier rather than the condenser.

BLOCK-UNION TYPE:

Remove the bolts securing the inlet and connections to the condenser.

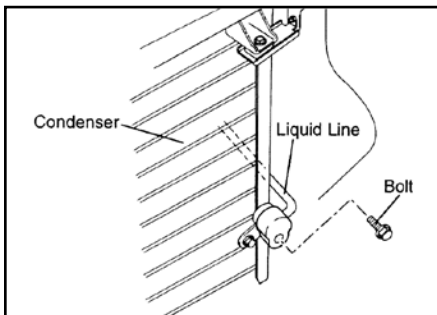

UNION-NUT TYPE:

Use two wrenches to disconnect the outlet lines to the condenser.

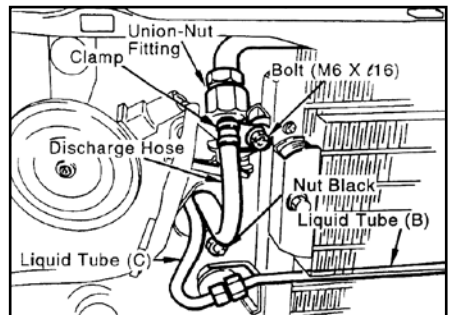

4. Locate and remove the condenser mounting bracket fasteners.

NOTE: Save plastic clips, grommets, cushioning, brackets, spacers, bushings and hardware as they will be needed to install the replacement condenser.

5. Before removal, insert a piece of cardboard in front of the radiator to protect the fins and carefully remove the condenser from the vehicle.

⚠CAUTION: Be careful not to damage the radiator or vehicle harness.

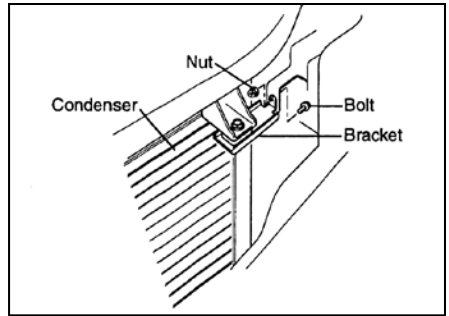

A/C Condenser Installation

NOTE: DENSO strongly recommends the replacement of the receiver-drier or accumulator when the A/C system has been opened and exposed to atmospheric conditions during the repair process.

1. Install rubber cushions, packing and brackets onto the condenser.
2. If the mounting brackets have been adjusted for shipping, reposition each mounting bracket to the correct position. If the mounting brackets are secured to the condenser assembly with bolts, slightly loosen each mounting bolt and reposition each bracket to the correct location and retighten the bolts. Be careful not to over-tighten the mounting bolts.

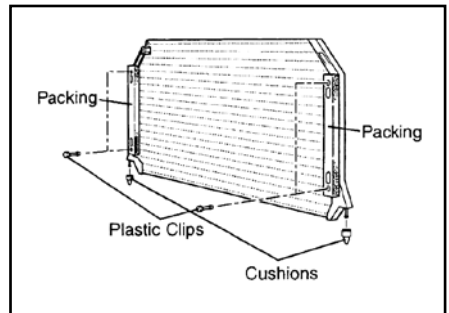

NOTE: Mounting hardware will vary by vehicle. Unless new mounting hardware is supplied or purchased, reuse the plastic clips, grommets, cushioning, brackets, spacers, bushings and hardware from the original condenser. Before installation, insert a piece of cardboard in front of the radiator to protect the fins.

3. Install the condenser into the vehicle.

NOTE: Before tightening the condenser fasteners, remove the cardboard in front of the radiator, used to protect the fins.

4. Tighten the condenser mounting brackets and hardware previously removed.

NOTE: Tighten fasteners to specifications. Refer to manufacturer's service manual for proper specifications.

5. Remove and discard any caps covering the condenser inlet and outlet openings.
6. Using the proper refrigerant oil, lubricate and install new O-rings onto the tubes/hoses. Refer to the manufacturer's source manual for proper refrigerant oil.

7. Reinstall refrigerant lines as follows:

BLOCK-UNION TYPE:

1. Assemble the refrigerant lines to the condenser, then install the bolts securing the lines to the condenser.
2. Tighten the bolts to specifications.

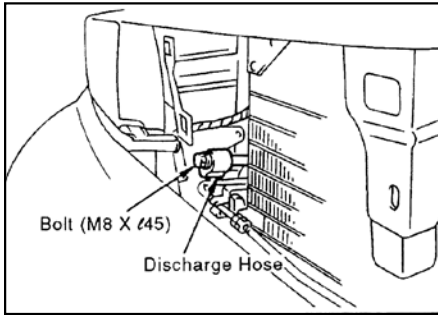

UNION-NUT TYPE:

1. Assemble the refrigerant lines to the condenser, then hand tighten the tube fittings.
2. Tighten the fittings to specifications. Use two wrenches to prevent damaging the lines.

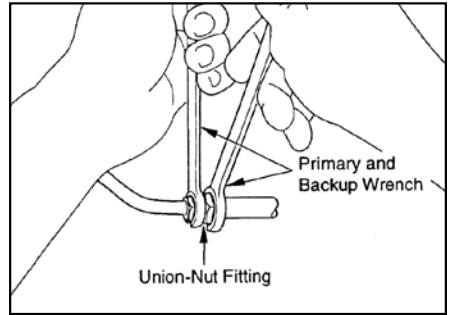

8. After completely finishing the installation, reinstall all parts that were temporarily removed.
9. Proceed with evacuation and recharging steps.

NOTE: To verify there are no leaks and to eliminate moisture from the system, evacuate the system for a minimum of 30 minutes. Wait 5 minutes after evacuation, then check for leaks before charging the system to factory specifications.