



Oxygen Sensor Removal & Installation Instructions

Universal 4 Wire Applications

These are recommended steps to follow when removing and installing oxygen sensors. Refer to the factory service manual for specific instructions for your vehicle.

Definition of Terms

- ⚠WARNING:** Describes precautions that should be observed in order to prevent injury or death to the user during installation.
- ⚠CAUTION:** Describes precautions that should be observed in order to prevent damage to the vehicle or its components, which may occur during installation if sufficient care is not taken.
- NOTE:** Provides additional information that facilitates installation work.

Removal Instructions

1. Exhaust system should be at ambient temperature.
2. Disconnect the oxygen sensor wire at the vehicle wire harness. Note the routing of the oxygen sensor wire.
3. Remove the oxygen sensor with the appropriate tool(s). (Ratchet & socket or wrench)
4. Check the threads on the exhaust manifold/pipe to make sure they are not damaged. If necessary, use the correct size tap to clean and repair the threads.
5. Compare the original and the new oxygen sensor(s) for the correct thread size, connector, number of wires and overall length.
6. With the two sensors laid out side by side, cut off the original sensor so overall length will be 3"- 4" longer than before. (See Fig. 1) This will allow connections to be made at evenly spaced intervals so the heat shrink tube can fit over the butt connections and the finished overall length to match the original.

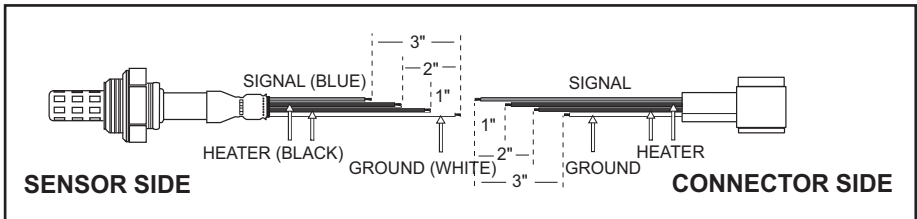

Fig. 1

⚠CAUTION: Refer to the appropriate connector illustration for wiring connections specific to your vehicle. If in doubt, use the factory service manual to prevent improper connections which may damage the vehicle ECU.

7. Trim blue signal wire (DENSO sensor side) approximately 3" back, then strip 1/4" of insulation from the wire and its corresponding wire (connector side). (See Fig. 2) Trim one black heater wire (DENSO sensor side) approximately 2" back and its corresponding wire (connector side) approximately 1" back. Trim the other black heater wire (sensor side) approximately 1" and its corresponding wire (connector side) back approximately 2". Trim the remaining wire (connector side) back approximately 3" and strip 1/4" of insulation from the wire and the white ground wire (sensor side).



Fig. 2

NOTE: Polarity is unimportant on heater wire connection.

8. Slide the heat shrink tube over the sensor wire(s).
9. Strip 1/4" of insulation from each wire, then insert corresponding wire ends into butt connectors and crimp with suitable crimping tool.

⚠CAUTION: If there is any question about wire connection, consult the manufacturer's vehicle service manual.

10. Center heat shrink tube over butt connector(s) and apply heat to seal the connection so water cannot enter. (See Fig. 3)

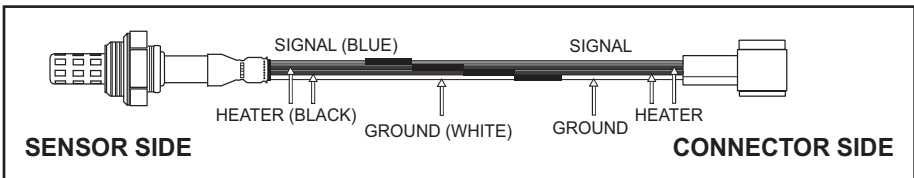

Fig. 3

Installation Instructions

⚠CAUTION: Oxygen sensors are fragile and must be handled with care; do not drop. Avoid exposing the sensor to RTV silicone based products.

1. Before installation, apply anti-seize compound to the threads of the new oxygen sensor. (Disregard for flange type sensor.)

⚠WARNING: Anti-seize compound may cause irritation to the skin or eyes. In case of contact, wash affected area with soap and water. In case of eye contact, flush with water for 15 minutes. If irritation persists, consult a physician. If swallowed, do not induce vomiting.

Keep out of reach of children.

2. Install the new oxygen sensor by hand, making sure it is not cross-threaded, and then torque to manufacturer's specifications. (For flange type sensor, use new gasket included with sensor.)
3. Route the new oxygen sensor wire along the original route to the vehicle wire harness and plug it in.

⚠CAUTION: Keep the oxygen sensor wire away from any hot surfaces/moving parts.

CHRYSLER 4-WIRE FEMALE STYLE CONNECTOR

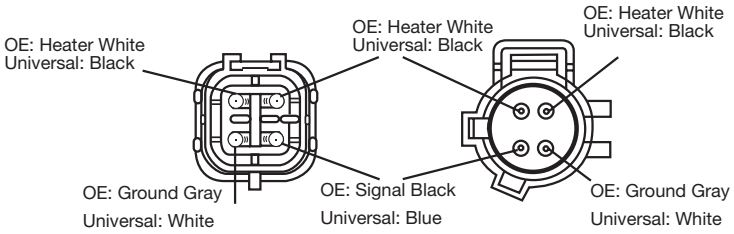

CHRYSLER 4-WIRE

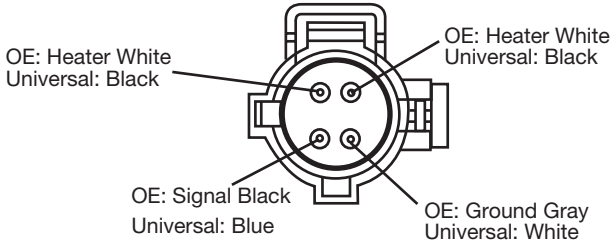

FORD 4-WIRE IMPORT/MAZDA APPLICATION

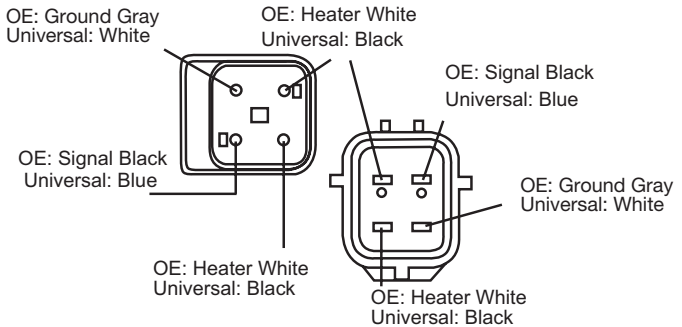

CHRYSLER 4-WIRE

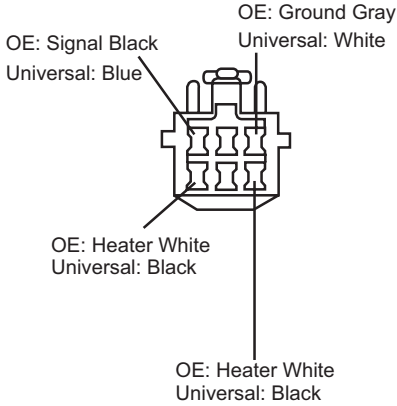

LATE FORD 4-WIRE (SMALL CONN.)

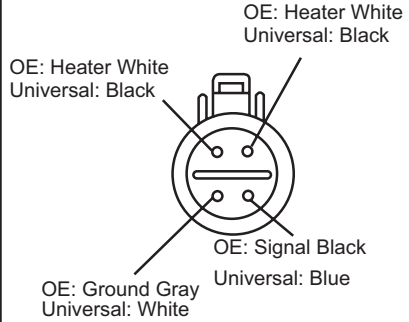

GM 4-WIRE (WEATHERPACK CONN.)

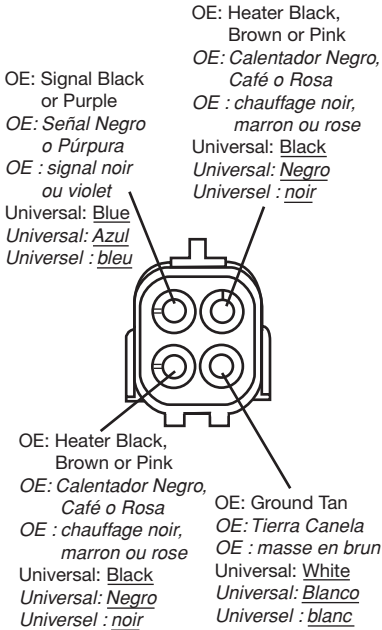

MERCURY/NISSAN 4-WIRE SENSORS

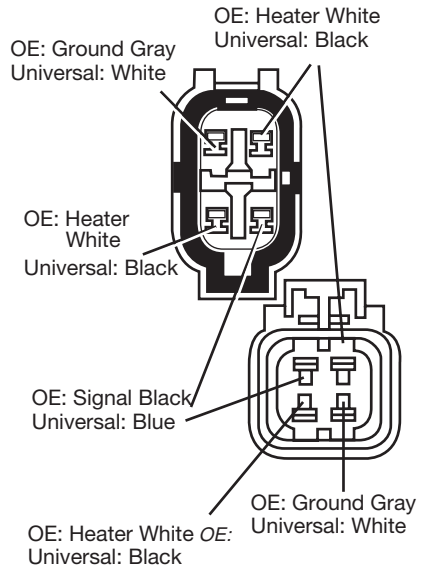

GM 4-WIRE (METRI-PACK CONN.)

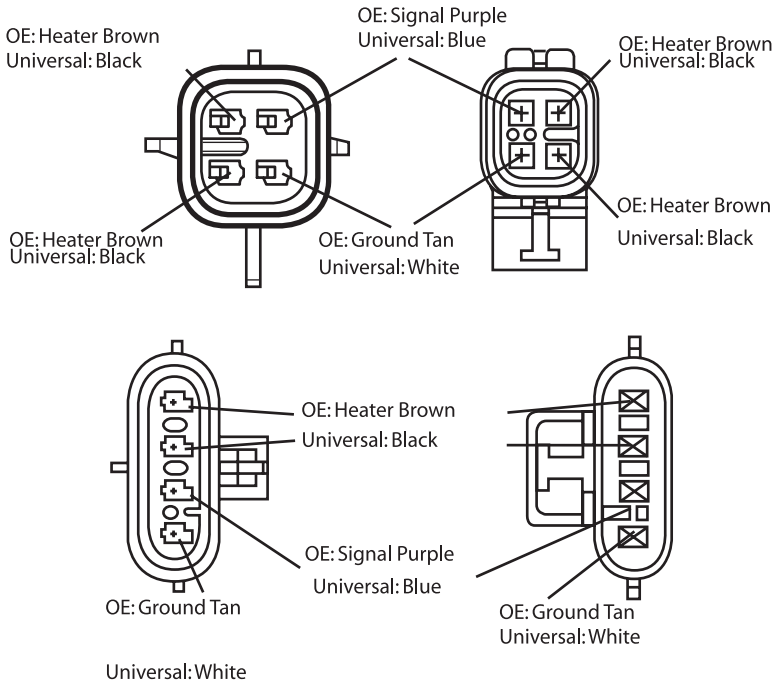

ACURA/HONDA 4-WIRE

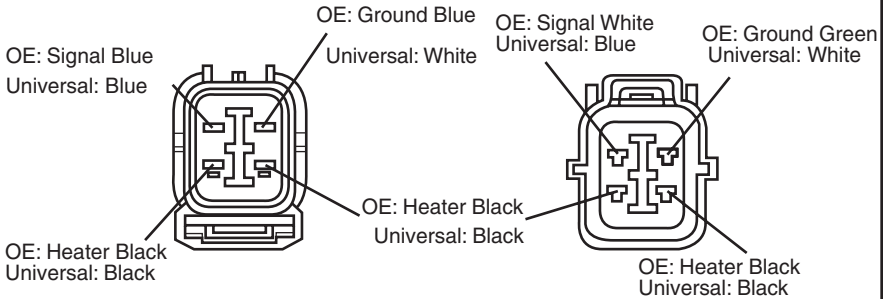

**ISUZU 4-WIRE
(WEATHERPACK CONN.)**

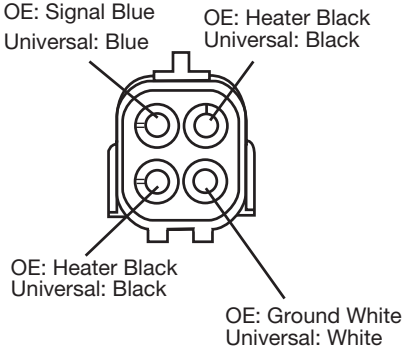

MAZDA 4-WIRE

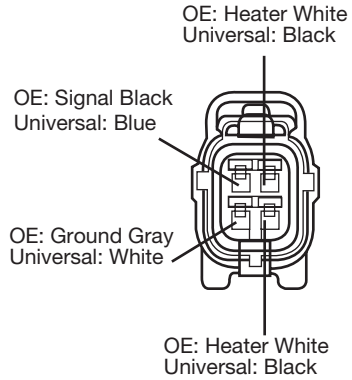

BMW 4-WIRE

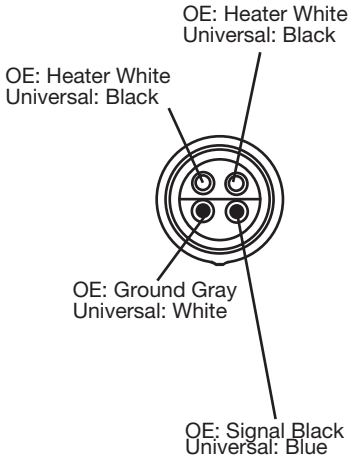

BMW 4-WIRE

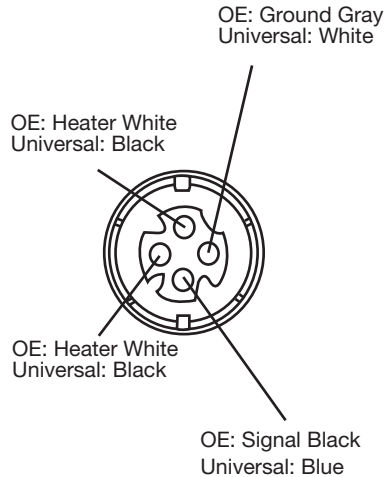

MITSUBISHI & CHRYSLER IMPORT

OE: Signal Blue,
Universal: Blue

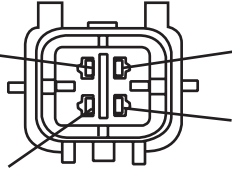

OE: Heater Black
Universal: Black

OE: Ground White
OE: *Tierra Blanco*
OE: *masse blanc*
Universal: White
Universal: Blanco
Universel: blanc

OE: Signal Blue,
or Yellow
Universal: Blue

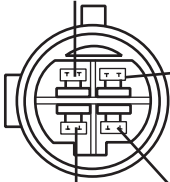

OE: Ground Gray
Universal: White

OE: Heater White
Universal: Black

OE: Heater White
Universal: Black

OE: Ground White,
Universal: White

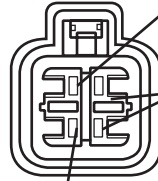

OE: Heater Black
Universal: Black

OE: Signal Blue, Black or Yellow
Universal: Blue

OE: Signal Black
Universal: Blue

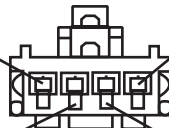

OE: Heater White
Universal: Black

OE: Ground White,
Gray or Green
Universal: White

OE: Heater White
Universal: Black