

# DEMCO

Doing Our Best to Provide You the Best

## BASEPLATE 9519330

Chevrolet & GMC 1500

Pin height - 22-1/2"

Center - 31-1/4"

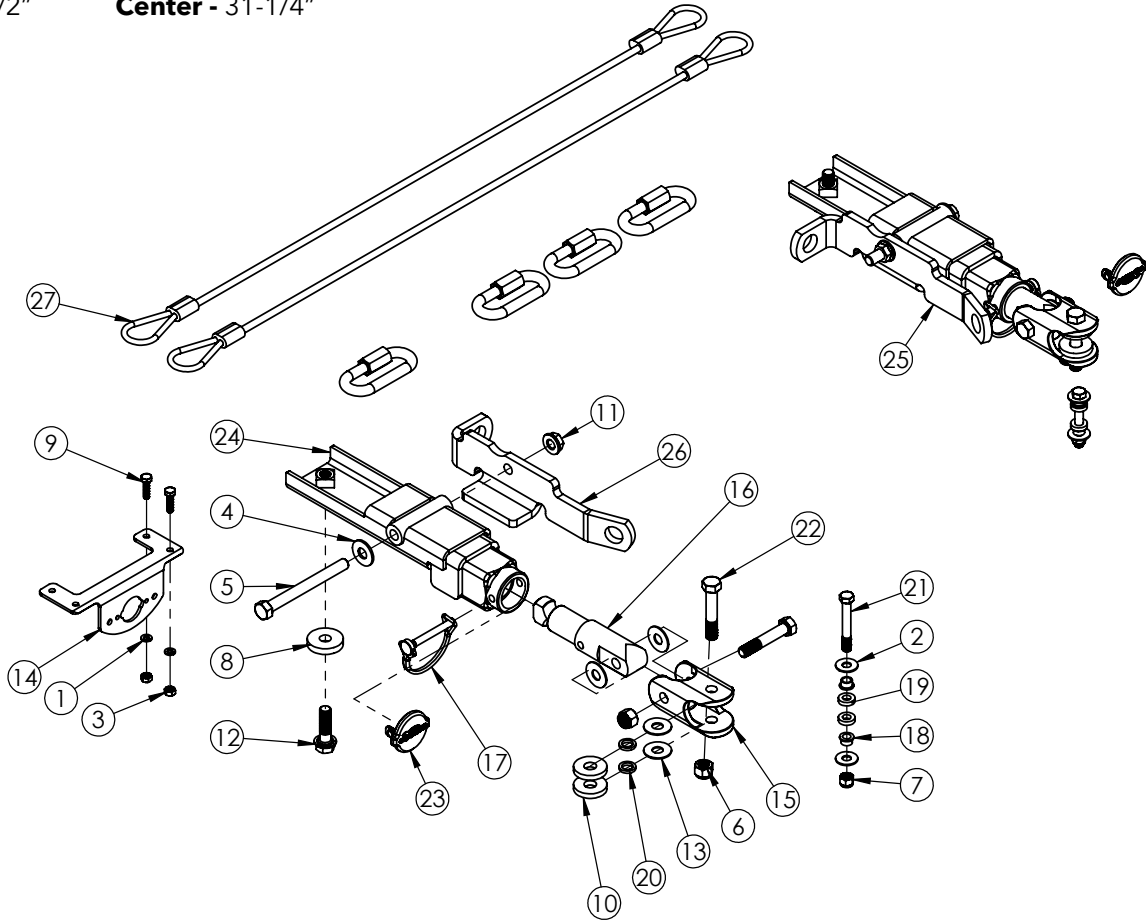

ITEM	PART #	QTY.	DESCRIPTION
1	00057	2	WASHER, .25 SPRING LOCK
2	00059	4	WASHER, FLAT .375
3	00062	2	NUT .25NC HEX
4	00085	2	.50 FLAT WASHER
5	01975	2	BOLT .50NC X 5.00 GR5 HEX
6	02178	4	NUT, .50NC LOCK, NY. INSERT
7	02592	2	NUT, .375NC NYLON LOCK
8	03804-95	2	WASHER STOP, EXTENDABLE LEG
9	04055	2	.25-20NC X 1 GD5 HEX
10	07908-95	4	HEAVY WASHER
11	10379	2	1/2" UNC FLANGED NUT
12	11992	2	BOLT, .50NC X 1.25 SERR FLG
13	13317	8	CLEVIS SPACER WASHER
14	13612-76	1	PLUG MOUNT

Please order replacement parts by PART NO. and DESCRIPTION.

ITEM	PART #	QTY.	DESCRIPTION
15	15040-81	2	END JOINT
16	15042-95	2	PULL STUD
17	15291	2	PN, 5/16" X 2.5 UL ROUND LOCK
18	15338	4	FLANGE BUSHING
19	15339	4	SPACER/WASHER NYLON
20	15340	4	SPACER/WASHER NYLON
21	15351-95	2	BOLT .375 X 2.75 W/ 1.75 SHANK
22	15352-95	4	BOLT .50NC X 2.75 W/1.75 SHANK
23	15675	2	TABLESS PLUG COVER
24	15970-76	2	PULL POD TABLESS
25	15971-76	1	LEFT CHAIN ANCHOR
26	15972-76	1	RIGHT CHAIN ANCHOR
27	6155	1	BASEPLATE SAFETY CABLE KIT
-	12329	1	LOCTITE (NOT SHOWN)

Please order replacement parts by PART NO. and DESCRIPTION.

# OPERATOR MANUAL

## INTRODUCTION

**WARNING: FAILURE TO FOLLOW THESE INSTRUCTIONS CAN RESULT IN LOSS OF TOWING VEHICLE CONTROL, SEPARATION OF THE TOW BAR FROM THE TOWING VEHICLE, SEPARATION OF THE TOWED VEHICLE FROM THE TOW BAR, CAUSING SEVERE PERSONAL INJURY, DEATH, OR PROPERTY DAMAGE.**

### CAUTION

Safety is of utmost importance at all times. There are several items that must be checked each time before using and while using a tow bar.

Before allowing anyone to hook up or operate a tow bar, be sure they have read and understand the proper operating procedure.

**DO NOT** use worn or damaged cables and/or pins.

Be sure the **SAFETY CABLES** are hooked, chassis to chassis, to both the towing and towed vehicles using the crisscross method.

Check clearance between vehicles in a turning situation.

Check base plate mounting bolts for tightness and frame for metal fatigue.

Do not load the towed vehicle with anything as you may exceed the towing capacity of the tow bar.

Keep fingers away from pivot points to prevent personal injury.

Be sure the steering components of the towed vehicle are properly aligned.

Demco baseplates are designed for use on factory vehicle suspension setups. Demco baseplates are not recommended for use on modified suspensions lowered or raised. Towing vehicle must be larger and at least 500 lbs. heavier than the towed vehicle and tow bar combined.

**NOTE:** This unit can be backed up in moderate increments. Any severe backwards cornering could result in damage to the Tow Bar and/or towed vehicle chassis.

**For automatic transmissions:** Consult your vehicle owners manual for towing suitability with the drive shaft connected. Otherwise, the towed vehicle will have to be equipped with a transmission pump or drive shaft disconnect.

Check to make sure that all lights are in proper working order.

**The information on towability of vehicles is reprinted with permission of MotorHome® Magazine,** and is believed to be reliable. However, **Demco does not** warrant the information to be correct. Always consult your towed vehicle owner's manual and follow towing instructions. Each year, **MotorHome® Magazine,** compiles a list of vehicles that can be towed four-down behind a motorhome with no modifications required.

 **Caution: MotorHome® Magazine** left out any vehicles that have towing speed limits slower than 55 m.p.h., or distance limits of less than 200 miles. At a minimum, these vehicles require significant modification, such as the use of an aftermarket product, to make them towable. The availability of a **Demco Tow Bar Base Plate** does not imply that these vehicles can be modified or that there is an aftermarket product available. Refer to your vehicle owner's manual or consult your dealer to determine whether your vehicle can be modified to make it towable. Failure to observe this precaution could result in property damage or personal injury.

### IMPORTANT INSTALLATION ITEMS

DEMCO products and accessories are intended to be installed by professional installers with experience, proper equipment and the ability to do modification work. Installers with these qualifications can be found in RV and Automotive Service Centers.

If the car to be towed has been in an accident, the chassis may be damaged in an area where the Base Plate attaches. It may no longer be suitable for towing. Extreme caution and careful examination are required in such a situation. It is also likely, even from a minor accident, that the hole alignment will be more difficult due to hole alignment problems.

Many DEMCO Base Plates are designed to use existing holes and hardware to mount the Base Plate to the towed vehicle. Even though the bolt is there, however, do not assume it is adequate for mounting the Base Plate. Manufacturers make many changes in hardware both within and between model years. Be sure the bolt is long enough to protrude past the nut a distance no less than 1/2 the diameter of the bolt, after the Base Plate is mounted. The threads should be in good condition. **We require that "LOCTITE® Blue" be used on all bolts.** If a new bolt is required, be sure it is SAE Grade 5 or Metric 8.8.

**NOTE: The dimensional variations between otherwise identical vehicles can be considerable. Some minor modifications may have to be made to ensure a proper fit.**

#### BOLT TORQUE SPECIFICATIONS STANDARD BOLTS:                      METRIC BOLTS:

Size	Grade	Torque	Size	Grade	Torque
5/16"	5	18 ft/lbs	8mm	8	23 ft/lbs
3/8"	5	30 ft/lbs	10mm	8	45 ft/lbs
7/16"	5	50 ft/lbs	12mm	8	78 ft/lbs
1/2"	5	75 ft/lbs	14mm	8	125 ft/lbs



**1. All Models:** Open hood and remove 12 push fasteners from the top of plastic cover and remove cover.



**4. GMC Only:** Bumper fascia removal: remove one screw from fender trim and one bolt from inner wheel well. Pull fender trim back and remove one bolt, fascia to fender.  
**NOTE:** removing an extra screw from fender trim may help removing fascia bolt.



**2. All Models:** Remove 4 bolts from top of grill.



**5. GMC Only:** Pull fascia away from fender carefully.



**3. Chevy Only:** Remove grill by gently pulling out on bottom of grill and work across the front until bottom is loose and pull the top back. Set aside.



**6. GMC Only:** Unstap 8 tabs from back side of fascia. 6 can be seen in the middle of the fascia, also one under each headlight. Continue to remove fascia and set aside.



## INSTALLATION INSTRUCTIONS



**7. GMC Only:** Remove 4 bolts from bottom edge of grill 2 on each side. Set aside grill. **NOTE:** hold onto grill when removing last bolt.



**10. All Models:** Remove tow hooks from each frame 1 long bolt and 1 short bolt. **NOTE:** on driver side, bumper mounting flange may have to be tapped up to allow long tow hook bolt to be removed approximately 1/8" up. Tap back down before mounting bumper. Tow hooks and bolts will not be reused.

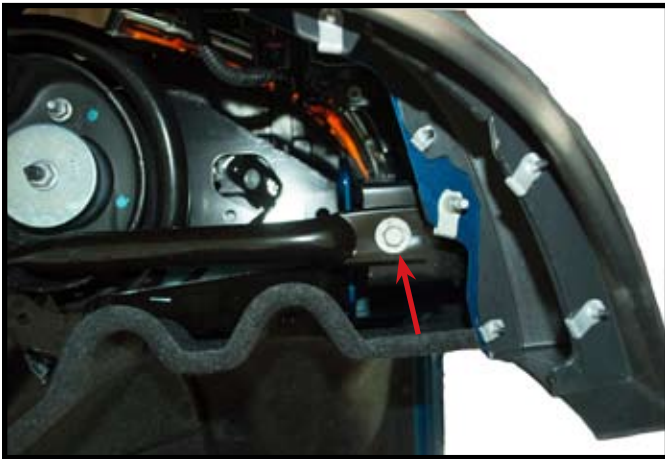

**8. All Models:** Remove one bolt from each side from bumper brace (see picture). Disconnect wiring plug located approximately in the center of back of bumper. Remove back half of wiring from bumper.



**11. All Models:** Slide baseplate into each frame opening. Use 1/2" x 5" bolt and 1/2" flatwasher through frame and baseplate. Attach quick-link inside of frame to chain anchor bracket and install chain anchor over 1/2" bolt. Use 1/2" serrate flange nut onto bolt. **NOTE:** In some cases, it might be easier to install chain anchor after bumper has been reinstalled.



**9. All Models:** Remove 4 bolts from top of bumper, two on each side. Set bumper aside.



**12. All Models:** Install heavy frame washer and 1-3/4" serrated head flange bolt into bottom of frame into rear of baseplate. Tighten 1/2" x 5" bolt first then 1-3/4" bolt. **NOTE:** use blue **LOCTITE**®.



**13. All Models:** Cut fascia as shown in picture. This picture is a view from the back side of bumper. Further trimming may be necessary trim as needed. Reinstall bumper, grill and plastic cover.

# INSTRUCTIONS

## INSTRUCTIONS FOR TOWED VEHICLE BASEPLATE SAFETY CABLES & PARTS BREAKDOWN

### Example #1

Wrap the safety cable around the baseplate crossmember and attach with one quicklink. Attach the other end of the safety cable to the vehicles frame rail or crossmember of the vehicles frame using another quicklink. **See illustration below. NOTE:** when routing cable, make sure cable does not touch or rub against wires, brake hoses, brake lines or axle shafts. Do this on each side of the baseplate.

Baseplate pictured is for illustration only and is not your specific baseplate.

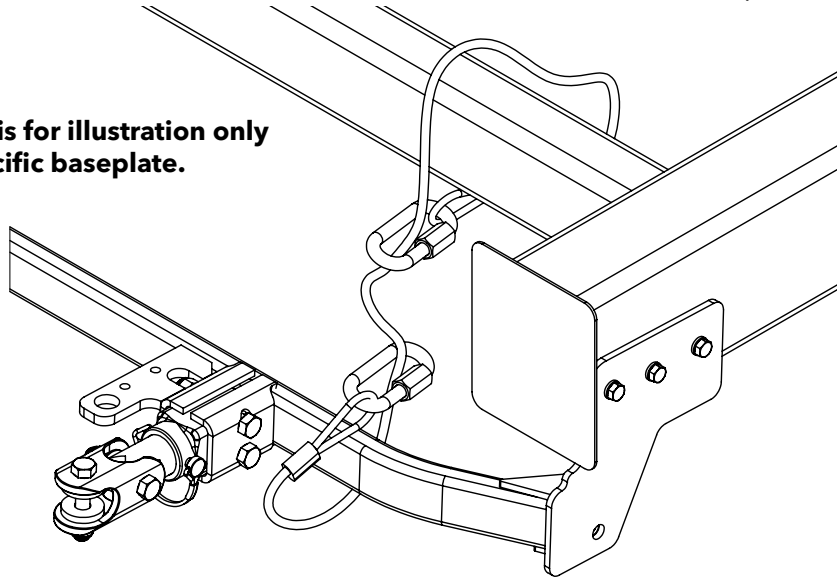

### Example #2

Some baseplate models have a hole to mount the quicklink and cable. Example: some baseplates may not have a crossmember from one side to the other, thus you have a quicklink mounting hole. **See illustration below:** this shows the use of just one quicklink. Other installs may require 2 quicklinks depending on baseplate model. **NOTE:** when routing cable, make sure cable does not touch or rub against wires, brake hoses, brake lines or axle shafts. Do this on each side of the baseplate.

Baseplate pictured is for illustration only and is not your specific baseplate.

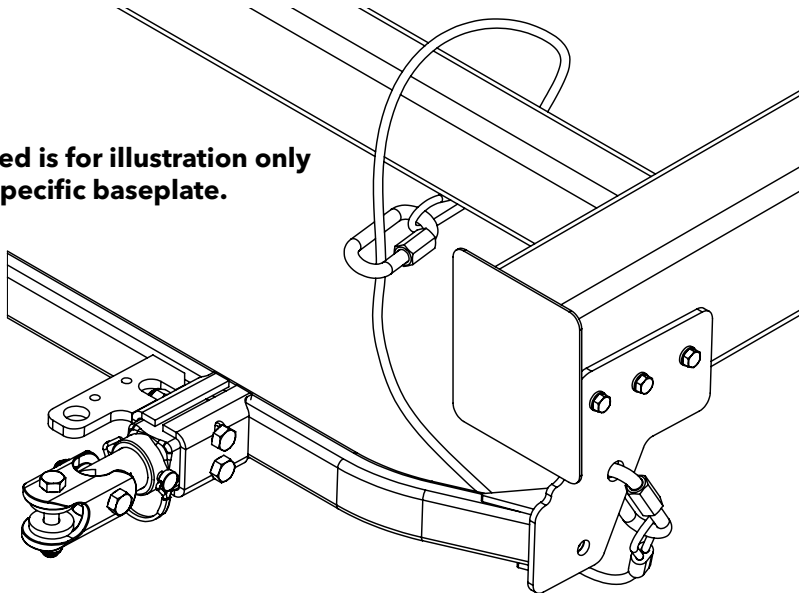

REF. NO.	PART NO.	QTY.	DESCRIPTION
-	6155	-	Safety Cable Kit
1.	-	2	36" Nylon coated safety cables rated @ 14,000 lbs. per pair
2.	-	4	1/2" Quicklinks rated @ 10,000 lbs. each

## INSTALLATION TO TOW BAR

### Demco Commander Tow Bar



Hardware Used: two 3/8" bolts, four 3/8" steel washers, four 3/8" poly washers, four 3/8" poly bushing and two 3/8" lock nuts.

1. Remove existing clevis from end of tow bar shaft.
2. Install poly bushing from inside clevis using a pliers to squeeze bushing into hole. You can use a rag or cardboard between pliers to protect bushing and clevis from damage. If bushing is hard to start in hole, hole may be cleaned out with 1/2" drill bit.
3. The 3/8" poly washers go in between the tow bar shaft and poly bushings.
4. The 3/8" steel washers go on the outside of clevis fastened by the 3/8" bolt and nut.
5. Tighten nut snug so you can still rotate clevis on tow bar shaft.

### Demco Excalibar II Tow Bar



Hardware Used: two 1/2" bolts, four 1/2" narrow rim poly washers and two 1/2" lock nuts

1. Remove existing clevis from end of tow bar shaft.
2. Install the 1/2" narrow rim poly washers between the tow bar shaft and clevis.
3. Tighten nut snug so you can still rotate clevis on tow bar shaft.

### Demco Dominator Tow Bar



Hardware Used: two 1/2" bolts, four 1/2" wide rim poly washers and two 1/2" lock nuts

1. Remove existing clevis from end of tow bar shaft.
2. Install the 1/2" wide rim poly washers between the tow bar shaft and clevis.
3. Tighten nut snug so you can still rotate clevis on tow bar shaft.

### Demco Excalibar or Aluminator Tow Bar



Hardware Used: two 1/2" bolts and two 1/2" lock nuts

1. Remove existing clevis from end of tow bar shaft.
2. Install tow bar shaft into clevis.
3. Tighten nut snug so you can still rotate clevis on tow bar shaft.

### Roadmaster Tow Bars



Hardware Used: two 1/2" bolts and two 1/2" lock nuts or two 1/2" bolts, four 1/2" - 1/4" thick washers and four 1/2" wide rim poly washers and two 1/2" lock nuts

1. Remove existing clevis from end of tow bar shaft.
2. If you tow bar came with a black bushing or red ends, install end into clevis and fasten using the provided 1/2" bolts and tighten nut snug so you can still rotate clevis on tow bar shaft.
3. If you have a Sterling towbar without the black bushing, install clevis using the 1/4" thick washers and 1/2" wide rim poly washers as shown in bottom picture.



## Hooking Up Tow Bar to Baseplate

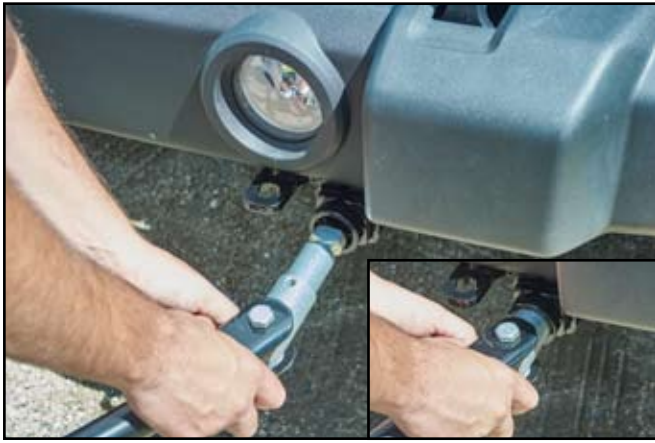

1. Insert pull tab into baseplate pull socket with the flat spot and locking hole facing up. Push pull tab into socket until it stops.



2. Rotate assembly 90° until lock pin holes line up. (Tab to clevis bolt will be horizontal while tow bar to clevis bolt will be vertical).



3. Insert locking pin into cross hole. If pin does not install, pull tab may not be installed correctly or try rotating tab 180° and try again. Hook up safety cables and other equipment required for towing your vehicle.

## Unhooking Tow Bar from Baseplate

1. Release the pressure from tow bar as stated in your tow bar manual.
2. Reverse the hooking up process.

## Plug Cover Instructions

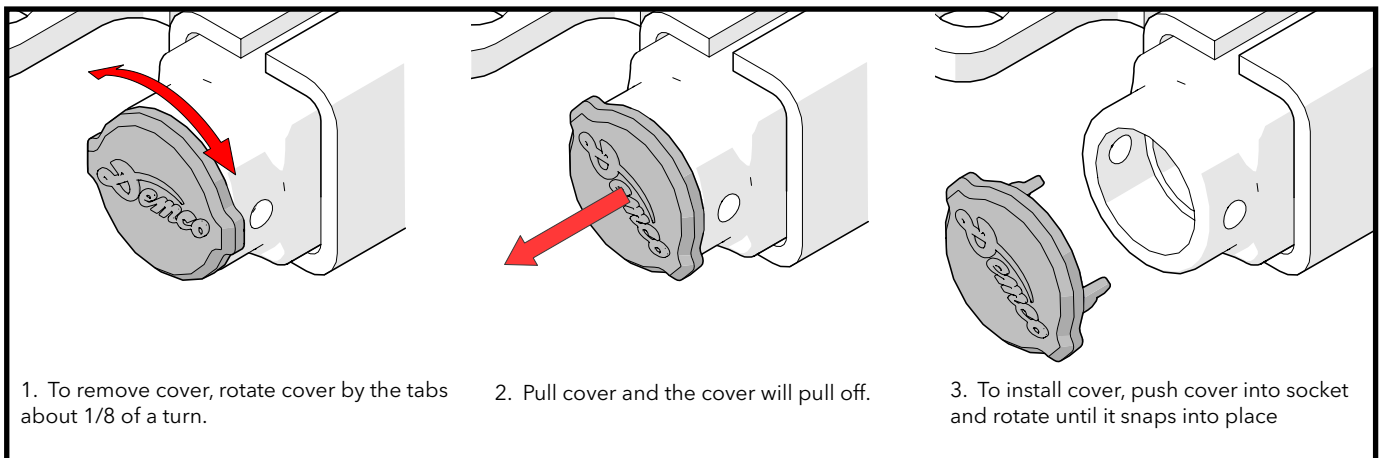

**DEMCO**