

Demco

Dodge Durango



BASEPLATE

Pin height - 18-1/2"

Centers - 27-3/4"

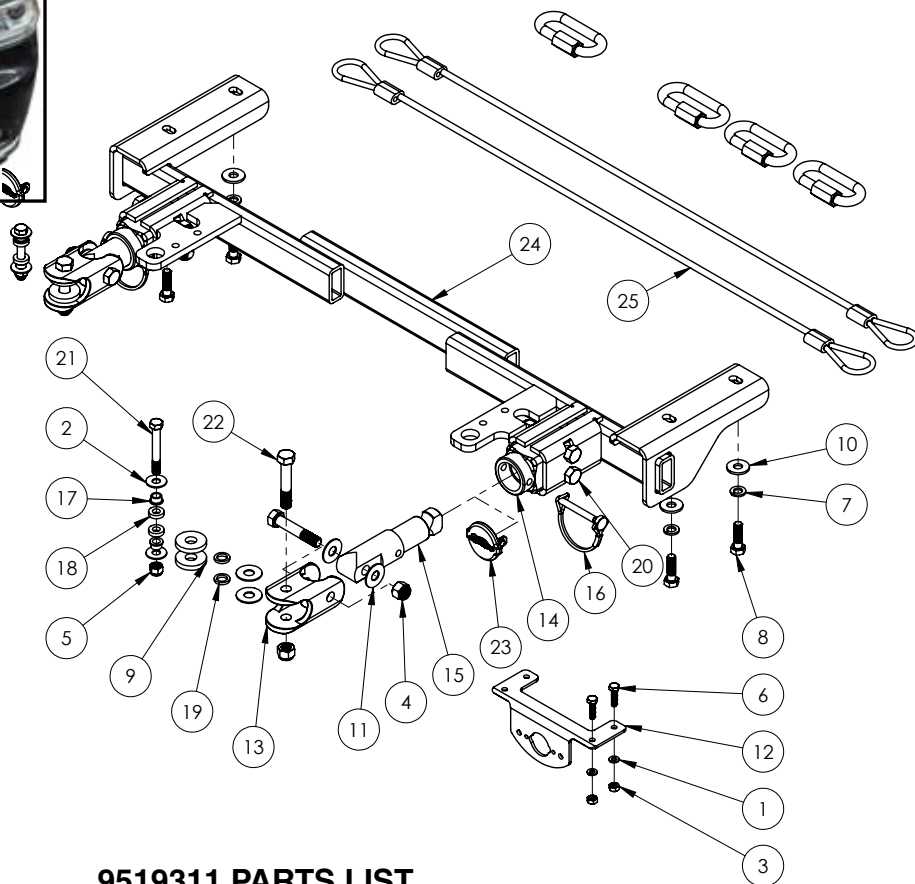

9519311 PARTS LIST

ITEM	PART #	QTY	DESCRIPTION
1	00057	2	WASHER, .25 SPRING LOCK
2	00059	4	WASHER, FLAT .375
3	00062	2	NUT .25NC HEX
4	02178	8	NUT, .50NC LOCK, NY. INSERT
5	02592	2	NUT, .375NC NYLON LOCK
6	04055	2	.25-20NC X 1 GD5 HEX
7	07284	4	WASHER, SPRING LOCK, 10MM
8	07291	4	BOLT, 10MM-1.50 X 50MM-GR. 8.8
9	07908-95	4	HEAVY WASHER
10	09229	4	WASHER, FENDER, 10MM
11	13317	8	CLEVIS SPACER WASHER
12	13612-76	1	PLUG MOUNT
13	15040-81	2	END JOINT
14	15041-76	2	PULL BLOCK

Please order replacement parts by PART NO. and DESCRIPTION.

ITEM	PART #	QTY	DESCRIPTION
15	15042-95	2	PULL STUD
16	15291	2	PN, 5/16" X 2.5 UL WIRE LOCK
17	15338	4	FLANGE BUSHING
18	15339	4	SPACER/WASHER NYLON
19	15340	4	SPACER/WASHER NYLON
20	15350	4	BOLT .50NC X 3.25 GR8 HEX
21	15351-95	2	BOLT .375 X 2.75 W/ 1.75 SHANK
22	15352-95	4	BOLT .50NC X 2.75 W/1.75 SHANK
23	15675	2	BASEPLATE PLUG COVER
24	15790-76	1	BASEPLATE CROSSMEMBER
	6155	1	BASEPLATE SAFETY CABLE KIT
-	5937	1	PLUG MNT KIT (INCLUDES 1,3,6,12)
-	09551	4	PLASTIC POP RIVET (NOT SHOWN)
-	12329	1	THREAD LOCK (NOT SHOWN)

Please order replacement parts by PART NO. and DESCRIPTION.

ASSEMBLY
OPERATION
REPLACEMENT PARTS

READ complete manual CAREFULLY
BEFORE attempting operation.

Doing Our Best to Provide You the Best

WARNING: FAILURE TO FOLLOW THESE INSTRUCTIONS CAN RESULT IN LOSS OF TOWING VEHICLE CONTROL, SEPARATION OF THE TOW BAR FROM THE TOWING VEHICLE, SEPARATION OF THE TOWED VEHICLE FROM THE TOW BAR, CAUSING SEVERE PERSONAL INJURY, DEATH, OR PROPERTY DAMAGE.

CAUTION

Safety is of utmost importance at all times. There are several items that must be checked each time before using and while using a tow bar.

Before allowing anyone to hook up or operate a tow bar, be sure they have read and understand the proper operating procedure.

DO NOT use worn or damaged cables and/or pins.

Be sure the **SAFETY CABLES** are hooked, chassis to chassis, to both the towing and towed vehicles using the crisscross method.

Check clearance between vehicles in a turning situation.

Check base plate mounting bolts for tightness and frame for metal fatigue.

Do not load the towed vehicle with anything as you may exceed the towing capacity of the tow bar.

Keep fingers away from pivot points to prevent personal injury.

Be sure the steering components of the towed vehicle are properly aligned.

Demco baseplates are designed for use on factory vehicle suspension setups. Demco baseplates are not recommended for use on modified suspensions lowered or raised. Towing vehicle must be larger and at least 500 lbs. heavier than the towed vehicle and tow bar combined.

NOTE: This unit can be backed up in moderate increments. Any severe backwards cornering could result in damage to the Tow Bar and/or towed vehicle chassis.

For automatic transmissions: Consult your vehicle owners manual for towing suitability with the drive shaft connected. Otherwise, the towed vehicle will have to be equipped with a transmission pump or drive shaft disconnect.

Check to make sure that all lights are in proper working order.

The information on towability of vehicles is reprinted with permission of MotorHome® Magazine, and is believed to be reliable. However, **Demco does not** warrant the information to be correct. Always consult your towed vehicle owner's manual and follow towing instructions. Each year, **MotorHome® Magazine,** compiles a list of vehicles that can be towed four-down behind a motorhome with no modifications required.

 **Caution: MotorHome® Magazine** left out any vehicles that have towing speed limits slower than 55 m.p.h., or distance limits of less than 200 miles. At a minimum, these vehicles require significant modification, such as the use of an aftermarket product, to make them towable. The availability of a **Demco Tow Bar Base Plate does not** imply that these vehicles can be modified or that there is an aftermarket product available. Refer to your vehicle owner's manual or consult your dealer to determine whether your vehicle can be modified to make it towable. Failure to observe this precaution could result in property damage or personal injury.

IMPORTANT INSTALLATION ITEMS

DEMCO products and accessories are intended to be installed by professional installers with experience, proper equipment and the ability to do modification work. Installers with these qualifications can be found in RV and Automotive Service Centers.

If the car to be towed has been in an accident, the chassis may be damaged in an area where the Base Plate attaches. It may no longer be suitable for towing. Extreme caution and careful examination are required in such a situation. It is also likely, even from a minor accident, that the hole alignment will be more difficult due to hole alignment problems.

Many DEMCO Base Plates are designed to use existing holes and hardware to mount the Base Plate to the towed vehicle. Even though the bolt is there, however, do not assume it is adequate for mounting the Base Plate. Manufacturers make many changes in hardware both within and between model years. Be sure the bolt is long enough to protrude past the nut a distance no less than 1/2 the diameter of the bolt, after the Base Plate is mounted. The threads should be in good condition. **We require that "LOCTITE® Blue" be used on all bolts.** If a new bolt is required, be sure it is SAE Grade 5 or Metric 8.8.

NOTE: The dimensional variations between otherwise identical vehicles can be considerable. Some minor modifications may have to be made to ensure a proper fit.

BOLT TORQUE SPECIFICATIONS

STANDARD BOLTS: METRIC BOLTS:

Size	Grade	Torque	Size	Grade	Torque
5/16"	5	18 ft/lbs	8mm	8	23 ft/lbs
3/8"	5	30 ft/lbs	10mm	8	45 ft/lbs
7/16"	5	50 ft/lbs	12mm	8	78 ft/lbs
1/2"	5	75 ft/lbs	14mm	8	125 ft/lbs

INSTALLATION INSTRUCTIONS

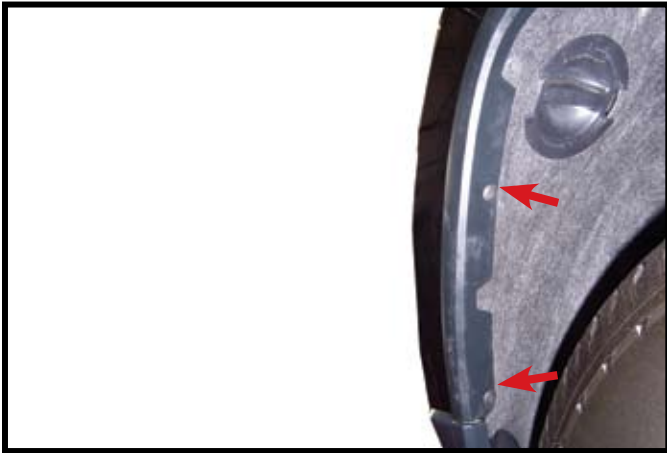

1. Drill out two plastic rivets from each wheel well with 3/16" drill bit. Remove rivets on each side.



4. Remove four plastic push fasteners from bottom of fascia.



2. Carefully pull out on molding trim attached to side of fascia.



5. Remove two plastic push fasteners from top of grill and pull up filler panel to allow grill to be released.



3. Remove one screw from fascia by trim molding and one screw from inner wheel well to bottom of fascia.



6. Carefully pull fascia out on each side by fender and pull fascia forward to remove. Unplug fog light if equipped.

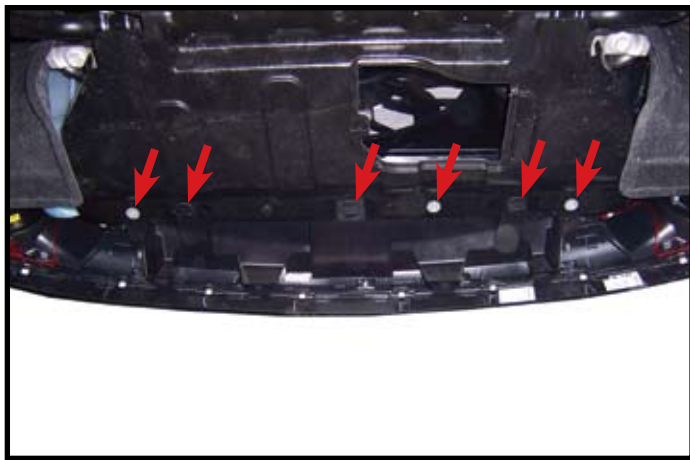

7. Temporarily remove air deflector by removing three turn clips and three screws on outer edge.



8. Cut the air deflector as shown by lines in picture and repeat on other side.



9. On drivers side, remove one bolt from front of wheel well to the side of skid plate to gain access to rear baseplate mounting hole. Repeat for other side if equipped with tow hooks.

If equipped with tow hooks continue on with step 10, if not equipped with tow hooks skip to step 17.

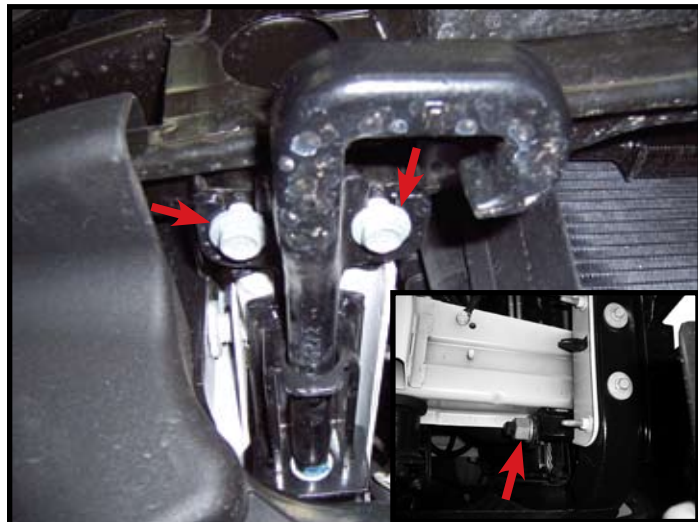

10. Remove rear tow hook nut and two front bolts of tow hook. Repeat for other side. **NOTE:** Removal of skid plate may be helpful.

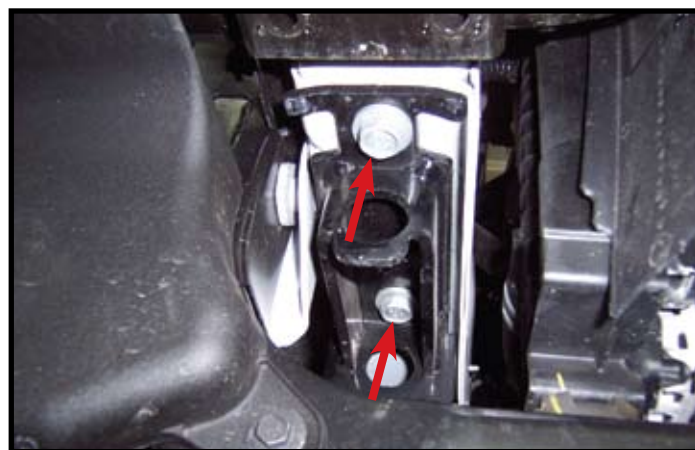

11. Remove tow hook bracket by removing two bolts. Repeat for other side. **NOTE:** Tow hooks will not be reused.

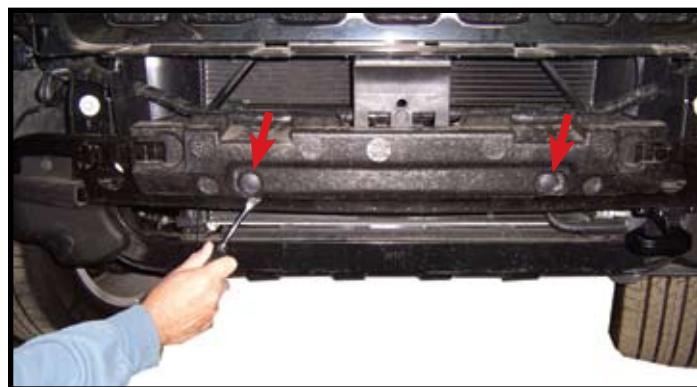

12. Remove foam filler from bumper by removing two plastic push fasteners.



13. Remove two bolts from center grill support and remove support.

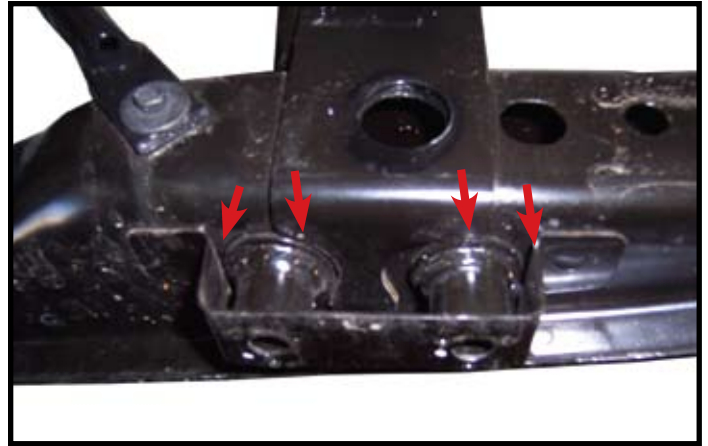

16. Remove front tow hook mount flush with the bottom of the bumper. Use torch or grinder to remove. Reinstall bumper and foam. **NOTE: Be careful not to damage radiator when reinstalling bumper.** Reinstall center grill support and grill assembly.

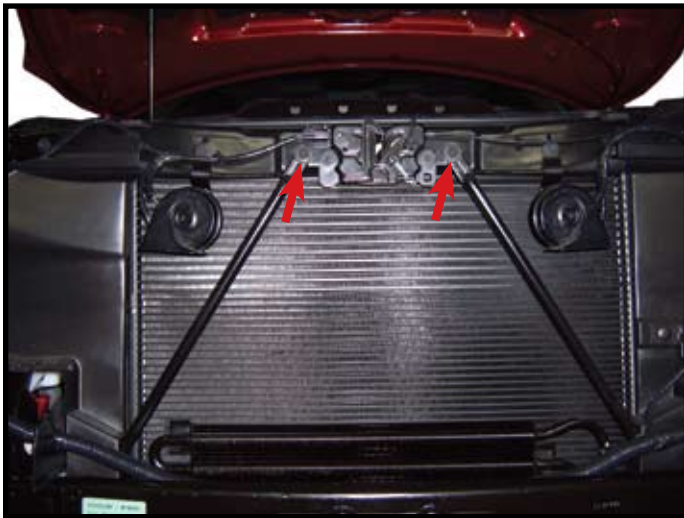

14. Remove two bolts from top bumper supports. **NOTE: Be careful not to damage radiator.**



17. With an assistant, install baseplate up against bottom of frame. Fasten using four 10mm flat fender washers, 10mm lock washers and 10mm-1.50 x 35mm bolts, thread into existing threaded holes in frame, **NOTE: Use blue LOCTITE® on all bolts and tighten all bolts according to chart on front page.**

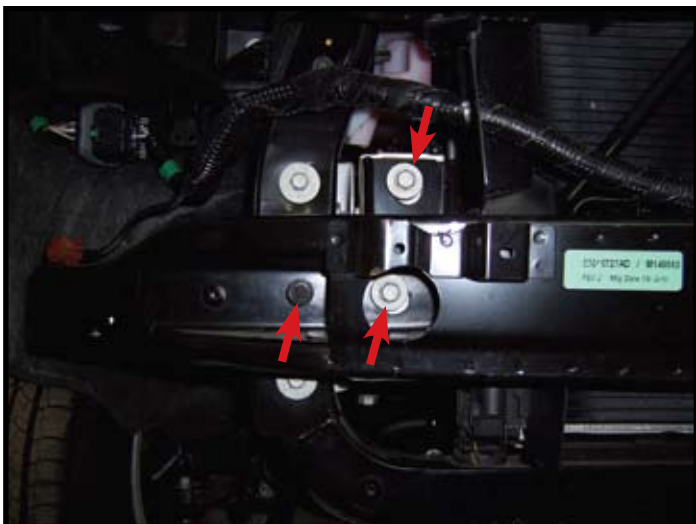

15. Remove three bolts from bumper on each side and remove. **NOTE: Be careful not to damage radiator when removing bumper.**

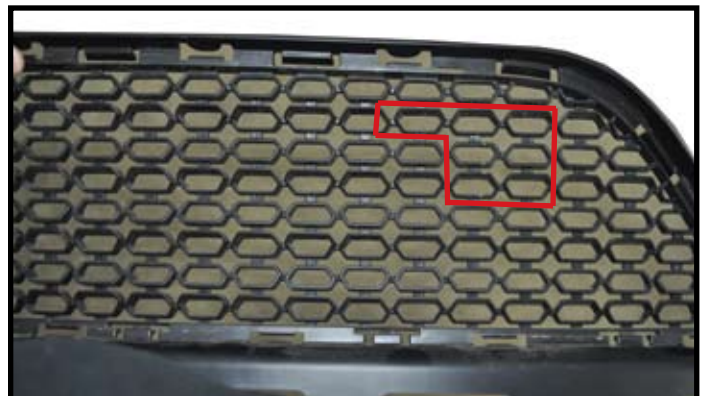

18. Trim lower grill opening as shown in picture, driver side shown and then trim passenger side.

19. Reinstall air deflector, fascia and plug in fog lights. Use the plastic rivet instructions to install the supplied rivets to fascia.

PLASTIC RIVET INSTALLATION



1. Insert plastic rivet into existing holes.



2. Use pliers as leverage tool for vise grip.



3. Use vise grip on rivet, and roll on pliers as shown.

INSTRUCTIONS FOR TOWED VEHICLE BASEPLATE SAFETY CABLES & PARTS BREAKDOWN

Example #1

Wrap the safety cable around the baseplate crossmember and attach with one quicklink. Attach the other end of the safety cable to the vehicles frame rail or crossmember of the vehicles frame using another quicklink. **See illustration below.** **NOTE:** when routing cable, make sure cable does not touch or rub against wires, brake hoses, brake lines or axle shafts. Do this on each side of the baseplate.

Example #2

Some baseplate models have a hole to mount the quicklink and cable. Example: some baseplates may not have a crossmember from one side to the other, thus you have a quicklink mounting hole. **See illustration below:** this shows the use of just one quicklink. Other installs may require 2 quicklinks depending on baseplate model. **NOTE:** when routing cable, make sure cable does not touch or rub against wires, brake hoses, brake lines or axle shafts. Do this on each side of the baseplate.

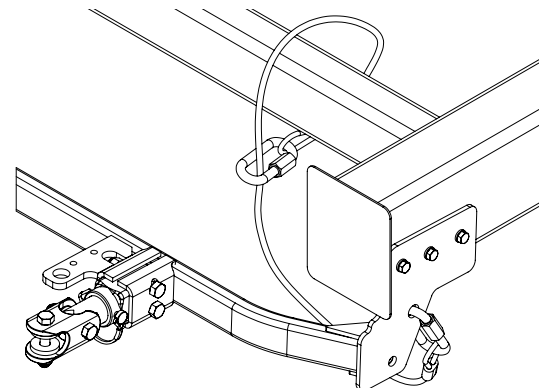
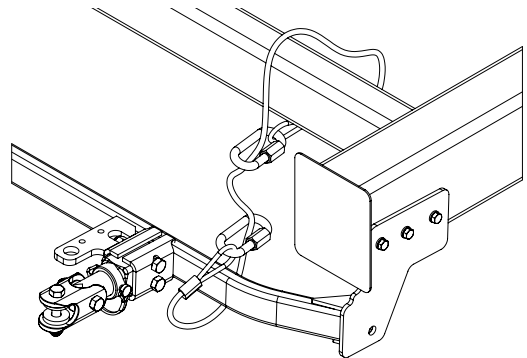

REF. NO.	PART NO.	QTY.	DESCRIPTION
-	6155	-	Safety Cable Kit
1.	-	2	36" Nylon coated safety cables rated @ 14,000 lbs. per pair
2.	-	4	1/2" Quicklinks rated @ 10,000 lbs. each

Installation to Tow Bar

Demco Commander Tow Bar



- Hardware Used: two 3/8" bolts, four 3/8" steel washers, four 3/8" poly bushing and two 3/8" lock nuts.
1. Remove existing clevis from end of tow bar shaft.
 2. Install poly bushing from inside clevis using a pliers to squeeze bushing into hole. You can use a rag or cardboard between pliers to protect bushing and clevis from damage. If bushing is hard to start in hole, hole may be cleaned out with 1/2" drill bit.
 3. The 3/8" poly washers go in between the tow bar shaft and poly bushings.
 4. The 3/8" steel washers go on the outside of clevis fastened by the 3/8" bolt and nut.
 5. Tighten nut snug so you can still rotate clevis on tow bar shaft.

Demco Excalibar II Tow Bar



- Hardware Used: two 1/2" bolts, four 1/2" narrow rim poly washers and two 1/2" lock nuts
1. Remove existing clevis from end of tow bar shaft.
 2. Install the 1/2" narrow rim poly washers between the tow bar shaft and clevis.
 3. Tighten nut snug so you can still rotate clevis on tow bar shaft.

Demco Dominator Tow Bar



- Hardware Used: two 1/2" bolts, four 1/2" wide rim poly washers and two 1/2" lock nuts
1. Remove existing clevis from end of tow bar shaft.
 2. Install the 1/2" wide rim poly washers between the tow bar shaft and clevis.
 3. Tighten nut snug so you can still rotate clevis on tow bar shaft.

Demco Excalibar or Aluminator Tow Bar



- Hardware Used: two 1/2" bolts and two 1/2" lock nuts
1. Remove existing clevis from end of tow bar shaft.
 2. Install tow bar shaft into clevis.
 3. Tighten nut snug so you can still rotate clevis on tow bar shaft.

Roadmaster Tow Bars



- Hardware Used: two 1/2" bolts and two 1/2" lock nuts or two 1/2" bolts, four 1/2" - 1/4" thick washers and four 1/2" wide rim poly washers and two 1/2" lock nuts
1. Remove existing clevis from end of tow bar shaft.
 2. If you tow bar came with a black bushing or red ends, install end into clevis and fasten using the provided 1/2" bolts and tighten nut snug so you can still rotate clevis on tow bar shaft.
 3. If you have a Sterling towbar without the black bushing, install clevis using the 1/4" thick washers and 1/2" wide rim poly washers as shown in bottom picture.

HOOKING UP TOW BAR TO BASEPLATE



1. Insert pull tab into baseplate pull socket with the flat spot and locking hole facing up. Push pull tab into socket until it stops.



3. Insert locking pin into cross hole. If pin does not install, pull tab may not be installed correctly or try rotating tab 180° and try again. Hook up safety cables and other equipment required for towing your vehicle



2. Rotate assembly 90° until lock pin holes line up. (Tab to clevis bolt will be horizontal while tow bar to clevis bolt will be vertical).

UNHOOKING TOW BAR FROM BASEPLATE

1. Release the pressure from tow bar as stated in your tow bar manual.
2. Reverse the hooking up process.

Plug Cover Instructions

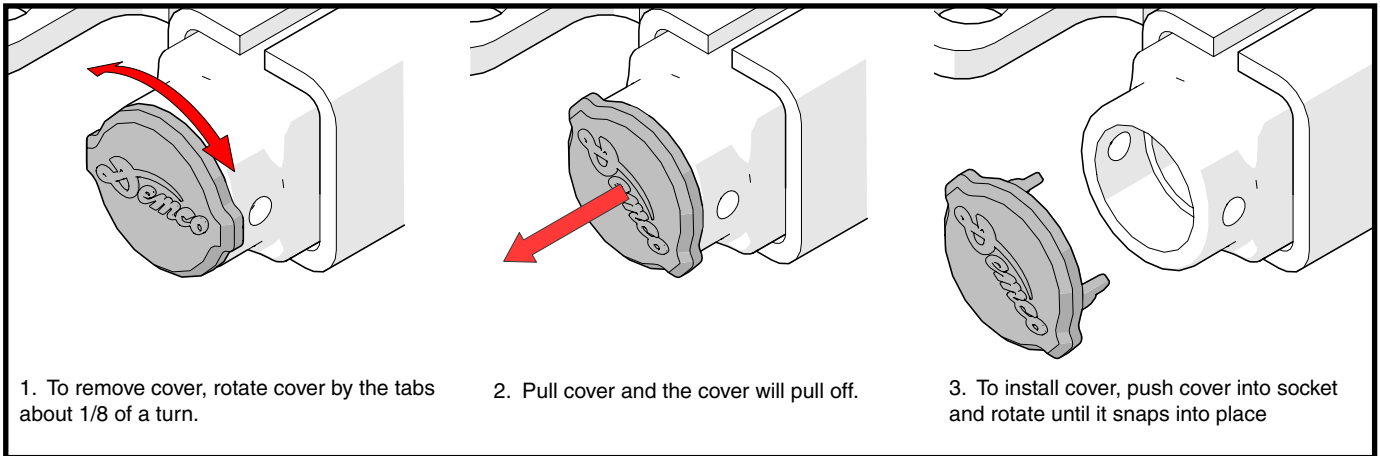

Demco