

Demco

JEEP Wrangler



BASEPLATE

Pin Height: 18-3/4" Centers: 22-1/4"

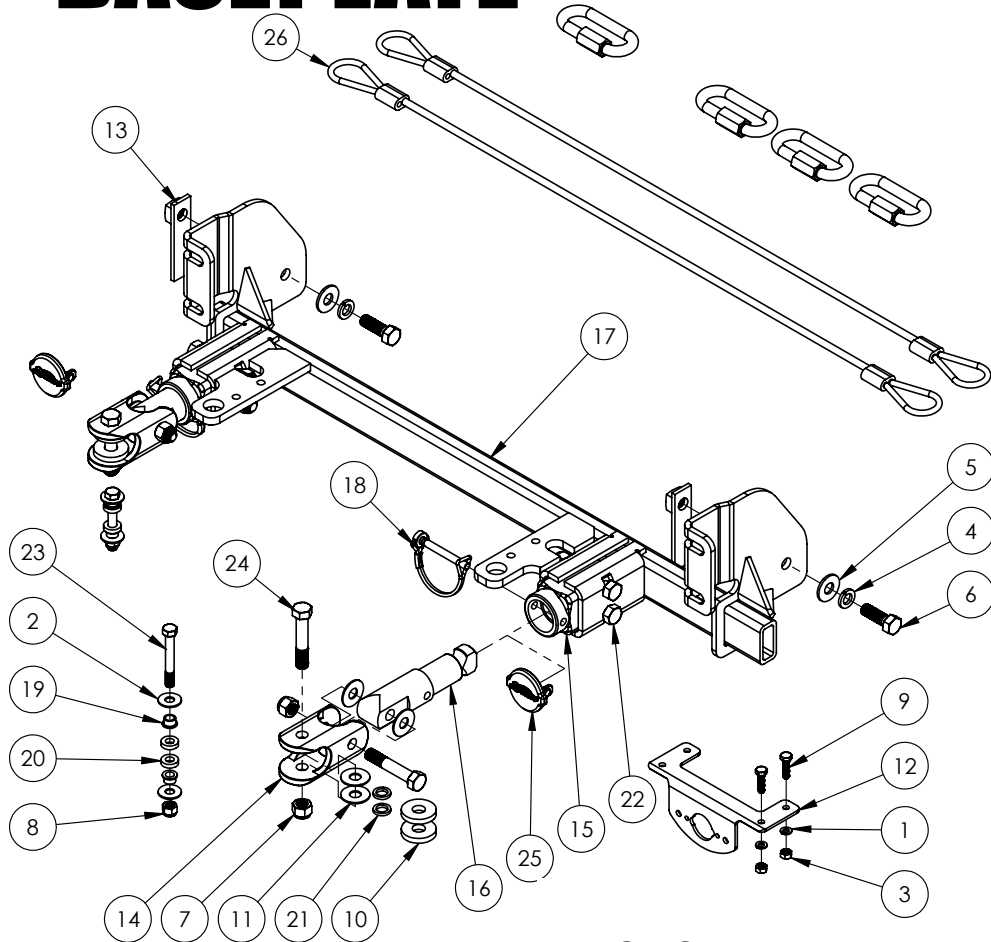

9519292 PARTS LIST

ITEM	PART #	QTY	DESCRIPTION
1	00057	2	WASHER, .25 SPRING LOCK
2	00059	4	WASHER, FLAT .375
3	00062	2	NUT .25NC HEX
4	00084	2	.50 LOCKWASHER
5	00085	2	.50 FLAT WASHER
6	01254	2	BOLT, .50 NC X 1.50 GR.5 HEX
7	02178	8	NUT, .50NC LOCK, NY. INSERT
8	02592	2	NUT, .375NC NYLON LOCK
9	04055	2	.25-20NC X 1 GD5 HEX
10	07908	4	HEAVY WASHER
11	13317	8	CLEVIS SPACER WASHER
12	13612	1	PLUG MOUNT
13	13908	2	NUT STRIP
14	15040	2	END JOINT

Please order replacement parts by PART NO. and DESCRIPTION.

ITEM	PART #	QTY	DESCRIPTION
15	15041	2	PULL BLOCK
16	15042-95	2	PULL STUD
17	15284	1	BASEPLATE F/ JEEP WRANGLER
18	15291	2	PN, 5/16" X 2.5 ROUND WIRE LOCK
19	15338	4	FLANGE BUSHING
20	15339	4	SPACER/WASHER NYLON
21	15340	4	SPACER/WASHER NYLON
22	15350	4	BOLT .50NC X 3.25 GR8 HEX
23	15351	2	BOLT .375 X 2.75 W/ 1.75 SHANK
24	15352	4	BOLT .50NC X 2.75 W/1.75 SHANK
25	15675	2	BASEPLATE PLUG COVER
26	6155	1	BASEPLATE SAFETY CABLE KIT

Please order replacement parts by PART NO. and DESCRIPTION.

ASSEMBLY
OPERATION
REPLACEMENT PARTS

READ complete manual CAREFULLY
BEFORE attempting operation.

Doing Our Best to Provide You the Best

WARNING: FAILURE TO FOLLOW THESE INSTRUCTIONS CAN RESULT IN LOSS OF TOWING VEHICLE CONTROL, SEPARATION OF THE TOW BAR FROM THE TOWING VEHICLE, SEPARATION OF THE TOWED VEHICLE FROM THE TOW BAR, CAUSING SEVERE PERSONAL INJURY, DEATH, OR PROPERTY DAMAGE.

CAUTION

Safety is of utmost importance at all times. There are several items that must be checked each time before using and while using a tow bar.

Before allowing anyone to hook up or operate a tow bar, be sure they have read and understand the proper operating procedure.

DO NOT use worn or damaged cables and/or pins.

Be sure the **SAFETY CABLES** are hooked, chassis to chassis, to both the towing and towed vehicles using the crisscross method.

Check clearance between vehicles in a turning situation.

Check base plate mounting bolts for tightness and frame for metal fatigue.

Do not load the towed vehicle with anything as you may exceed the towing capacity of the tow bar.

Keep fingers away from pivot points to prevent personal injury.

Be sure the steering components of the towed vehicle are properly aligned.

Demco baseplates are designed for use on factory vehicle suspension setups. Demco baseplates are not recommended for use on modified suspensions lowered or raised. Towing vehicle must be larger and at least 500 lbs. heavier than the towed vehicle and tow bar combined.

NOTE: This unit can be backed up in moderate increments. Any severe backwards cornering could result in damage to the Tow Bar and/or towed vehicle chassis.

For automatic transmissions: Consult your vehicle owners manual for towing suitability with the drive shaft connected. Otherwise, the towed vehicle will have to be equipped with a transmission pump or drive shaft disconnect.

Check to make sure that all lights are in proper working order.

The information on towability of vehicles is reprinted with permission of MotorHome® Magazine, and is believed to be reliable. However, **Demco does not** warrant the information to be correct. Always consult your towed vehicle owner's manual and follow towing instructions. Each year, **MotorHome® Magazine,** compiles a list of vehicles that can be towed four-down behind a motorhome with no modifications required.

 **Caution: MotorHome® Magazine** left out any vehicles that have towing speed limits slower than 55 m.p.h., or distance limits of less than 200 miles. At a minimum, these vehicles require significant modification, such as the use of an aftermarket product, to make them towable. The availability of a **Demco Tow Bar Base Plate does not** imply that these vehicles can be modified or that there is an aftermarket product available. Refer to your vehicle owner's manual or consult your dealer to determine whether your vehicle can be modified to make it towable. Failure to observe this precaution could result in property damage or personal injury.

IMPORTANT INSTALLATION ITEMS

DEMCO products and accessories are intended to be installed by professional installers with experience, proper equipment and the ability to do modification work. Installers with these qualifications can be found in RV and Automotive Service Centers.

If the car to be towed has been in an accident, the chassis may be damaged in an area where the Base Plate attaches. It may no longer be suitable for towing. Extreme caution and careful examination are required in such a situation. It is also likely, even from a minor accident, that the hole alignment will be more difficult due to hole alignment problems.

Many DEMCO Base Plates are designed to use existing holes and hardware to mount the Base Plate to the towed vehicle. Even though the bolt is there, however, do not assume it is adequate for mounting the Base Plate. Manufacturers make many changes in hardware both within and between model years. Be sure the bolt is long enough to protrude past the nut a distance no less than 1/2 the diameter of the bolt, after the Base Plate is mounted. The threads should be in good condition. **We require that "LOCTITE® Blue" be used on all bolts.** If a new bolt is required, be sure it is SAE Grade 5 or Metric 8.8.

NOTE: The dimensional variations between otherwise identical vehicles can be considerable. Some minor modifications may have to be made to ensure a proper fit.

BOLT TORQUE SPECIFICATIONS

STANDARD BOLTS:			METRIC BOLTS:		
Size	Grade	Torque	Size	Grade	Torque
5/16"	5	18 ft/lbs	8mm	8	23 ft/lbs
3/8"	5	30 ft/lbs	10mm	8	45 ft/lbs
7/16"	5	50 ft/lbs	12mm	8	78 ft/lbs
1/2"	5	75 ft/lbs	14mm	8	125 ft/lbs

STANDARD BOLTS:			METRIC BOLTS:		
Size	Grade	Torque	Size	Grade	Torque
5/16"	5	18 ft/lbs	8mm	8	23 ft/lbs
3/8"	5	30 ft/lbs	10mm	8	45 ft/lbs
7/16"	5	50 ft/lbs	12mm	8	78 ft/lbs
1/2"	5	75 ft/lbs	14mm	8	125 ft/lbs

INSTALLATION INSTRUCTIONS



1. Remove plastic belly pan by removing six plastic push fasteners.

2. Remove bumper by removing eight hex nuts and four backer plates from the back side of bumper. Two backer plates will be used later. **Note:** Before bumper can be set aside, unplug fog lights if equipped and remove wiring clips from bumper.



3. Drill top right hole on drivers side bumper mount to 9/16" as shown.



4. Put baseplate up from driver's side pushing tight towards passenger side. Align front slotted holes in baseplate with round holes of vehicle's bumper flange. Clamp each side so baseplate doesn't move. **NOTE:** Baseplate mounts on the inside of the passengers frame and the outside of the drivers frame.



5. Using baseplate as template, drill 1/2" hole thru side of baseplate on each side. Install 1/2" x 1-1/2" bolt, 1/2" flat washer, 1/2" lock washer, and nut strip. Nut strip goes on frame side and bolt and washers thru baseplate side. Tighten bolts according to torque chart on front page. **Note:** Use **LOCTITE**® on all bolts and nuts.



6. Reinstall bumper and use previously removed bumper hex nuts (see picture below). **NOTE:** One bumper backer plate will be used on driver's side inside of frame and passenger's side outside of frame.



7. Re-attach plastic belly pan with two plastic push fasteners at points with arrows as shown above. Bring front of belly pan up to bumper and mark as shown in picture at locations where it meets the baseplate. Cut out marked locations and trim as needed. Re-attach front of belly pan with four plastic push fasteners.
8. Plug mount (item #11) may be installed if desired in convenience holes on either chain anchor or as desired. **NOTE:** Excess material may be trimmed from bracket.

INSTRUCTIONS FOR TOWED VEHICLE BASEPLATE SAFETY CABLES & PARTS BREAKDOWN

Example #1

Wrap the safety cable around the baseplate crossmember and attach with one quick-link. Attach the other end of the safety cable to the vehicles frame rail or crossmember of the vehicles frame using another quicklink. **See illustration below.** **NOTE:** when routing cable, make sure cable does not touch or rub against wires, brake hoses, brake lines or axle shafts. Do this on each side of the baseplate.

Baseplate pictured is for illustration only and is not your specific baseplate.

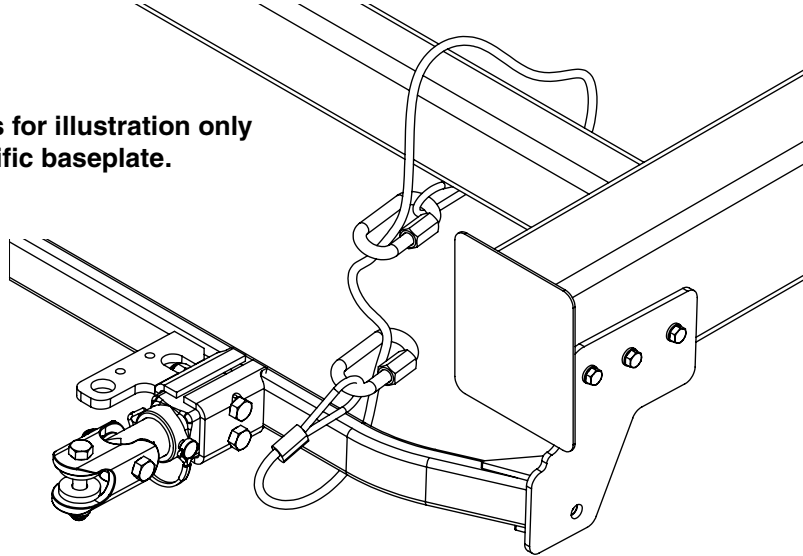

Example #2

Some baseplate models have a hole to mount the quicklink and cable. Example: some baseplates may not have a crossmember from one side to the other, thus you have a quicklink mounting hole. **See illustration below:** this shows the use of just one quicklink. Other installs may require 2 quicklinks depending on baseplate model. **NOTE:** when routing cable, make sure cable does not touch or rub against wires, brake hoses, brake lines or axle shafts. Do this on each side of the baseplate.

Baseplate pictured is for illustration only and is not your specific baseplate.

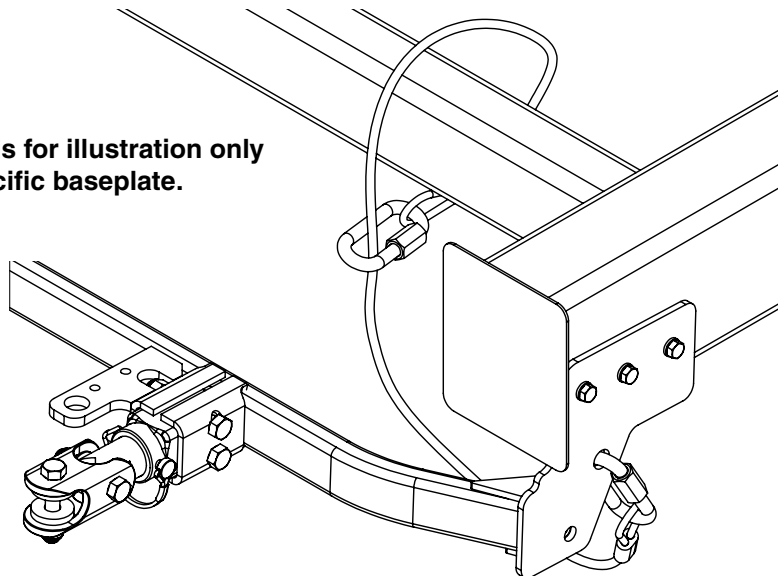

REF. NO.	PART NO.	QTY.	DESCRIPTION
-	6155	-	Safety Cable Kit
1.	-	2	36" Nylon coated safety cables rated @ 14,000 lbs. per pair
2.	-	4	1/2" Quicklinks rated @ 10,000 lbs. each

Installation to Tow Bar

Demco Commander Tow Bar



Hardware Used: two 3/8" bolts, four 3/8" steel washers, four 3/8" poly washers, four 3/8" poly bushing and two 3/8" lock nuts.

1. Remove existing clevis from end of tow bar shaft.
2. Install poly bushing from inside clevis using a pliers to squeeze bushing into hole. You can use a rag or cardboard between pliers to protect bushing and clevis from damage. If bushing is hard to start in hole, hole may be cleaned out with 1/2" drill bit.
3. The 3/8" poly washers go in between the tow bar shaft and poly bushings.
4. The 3/8" steel washers go on the outside of clevis fastened by the 3/8" bolt and nut.
5. Tighten nut snug so you can still rotate clevis on tow bar shaft.

Demco Excalibar II Tow Bar



Hardware Used: two 1/2" bolts, four 1/2" narrow rim poly washers and two 1/2" lock nuts

1. Remove existing clevis from end of tow bar shaft.
2. Install the 1/2" narrow rim poly washers between the tow bar shaft and clevis.
3. Tighten nut snug so you can still rotate clevis on tow bar shaft.

Demco Dominator Tow Bar



Hardware Used: two 1/2" bolts, four 1/2" wide rim poly washers and two 1/2" lock nuts

1. Remove existing clevis from end of tow bar shaft.
2. Install the 1/2" wide rim poly washers between the tow bar shaft and clevis.
3. Tighten nut snug so you can still rotate clevis on tow bar shaft.

Demco Excalibar or Aluminator Tow Bar



Hardware Used: two 1/2" bolts and two 1/2" lock nuts

1. Remove existing clevis from end of tow bar shaft.
2. Install tow bar shaft into clevis.
3. Tighten nut snug so you can still rotate clevis on tow bar shaft.

Roadmaster Tow Bars



Hardware Used: two 1/2" bolts and two 1/2" lock nuts or two 1/2" bolts, four 1/2" - 1/4" thick washers and four 1/2" wide rim poly washers and two 1/2" lock nuts

1. Remove existing clevis from end of tow bar shaft.
2. If you tow bar came with a black bushing or red ends, install end into clevis and fasten using the provided 1/2" bolts and tighten nut snug so you can still rotate clevis on tow bar shaft.
3. If you have a Sterling towbar without the black bushing, install clevis using the 1/4" thick washers and 1/2" wide rim poly washers as shown in bottom picture.

Hooking Up Tow Bar to Baseplate



1. Insert pull tab into baseplate pull socket with the flat spot and locking hole facing up. Push pull tab into socket until it stops.



2. Rotate assembly 90° until lock pin holes line up. (Tab to clevis bolt will be horizontal while tow bar to clevis bolt will be vertical).



3. Insert locking pin into cross hole. If pin does not install, pull tab may not be installed correctly or try rotating tab 180° and try again. Hook up safety cables and other equipment required for towing your vehicle

Unhooking Tow Bar from Baseplate

1. Release the pressure from tow bar as stated in your towbar manual.
2. Reverse the hooking up process.

Plug Cover Instructions

