



Dodge 1500
5 1/2', 6 1/2' & 8' Boxes
No Air Suspension

4/16
HJ32029, Rev 3



BOLT TORQUE SPECIFICATIONS

STANDARD BOLTS:

Size	Grade	Torque	Size	Grade	Torque
5/16"	5	20 ft/lbs.	9/16"	5	123 ft/lbs.
3/8"	5	35 ft/lbs.	5/8"	5	170 ft/lbs.
7/16"	5	56 ft/lbs.	3/4"	5	305 ft/lbs.
1/2"	5	85 ft/lbs.	7/8"	5	445 ft/lbs.
			1"	5	670 ft/lbs.

FRAME BRACKET

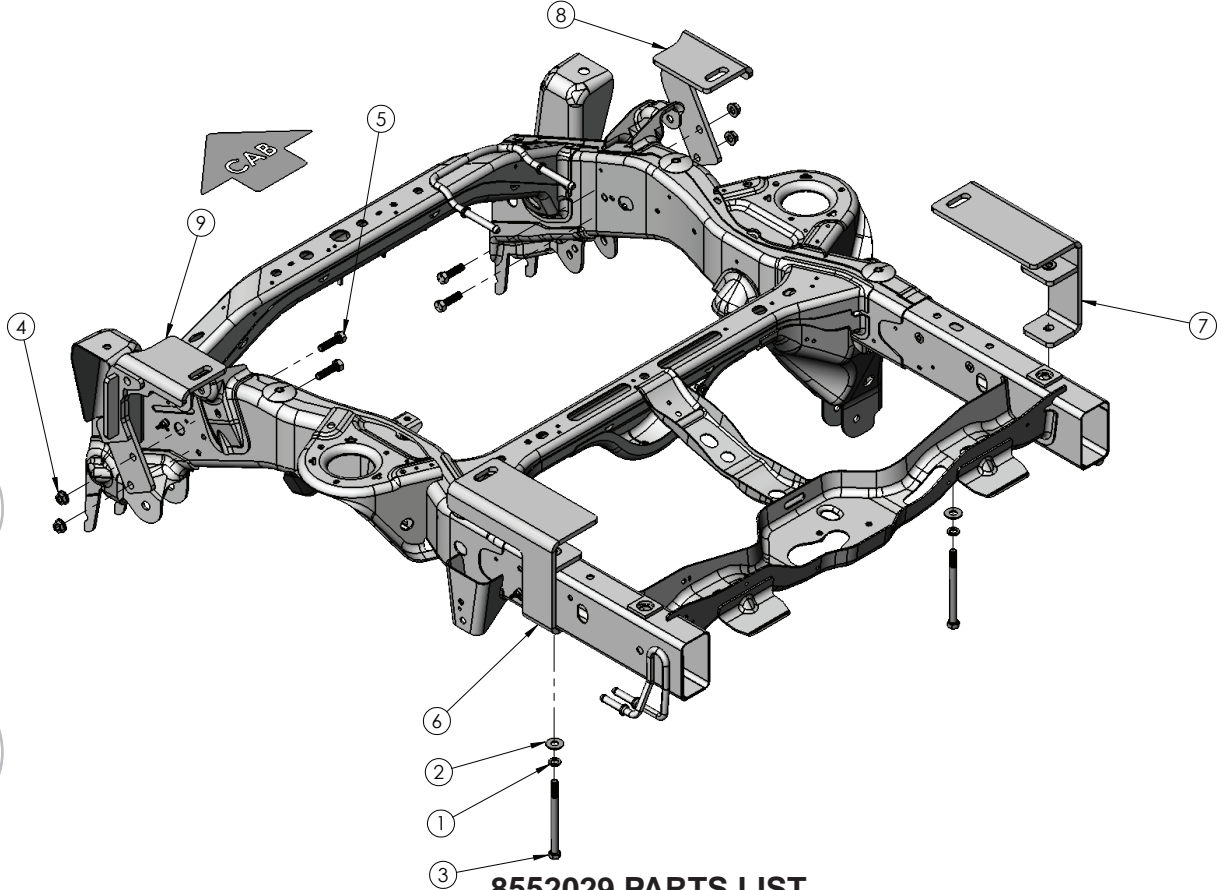

8552029 PARTS LIST

ITEM	PART #	DESCRIPTION	QTY.
1.	00084	1/2" Lock Washer	2
2.	00085	1/2" Flat Washer	2
3.	00349	1/2" NC x 6" Hex Bolt Gr.5	2
4.	10379	1/2" NC Serrated Flange Nut	4
5.	14266	1/2" NC x 1 3/4" Hex Bolt Knurled Gr.5	4
6.	14509-76	Rear Frame Bracket Driver Side	1
7.	14510-76	Rear Frame Bracket Passenger Side	1
8.	14512-76	Front Frame Bracket Passenger Side	1
9.	15397-76	Front UL Mounting Bracket Driver Side	1
10.	14238	1/2" Fish Wire (not shown)	1

Please order replacement parts by PART NO. and DESCRIPTION.

ASSEMBLY
OPERATION
REPLACEMENT PARTS

READ complete manual CAREFULLY
BEFORE attempting operation.

Doing Our Best to Provide You the Best

1. Jack rear of truck up and remove tires.

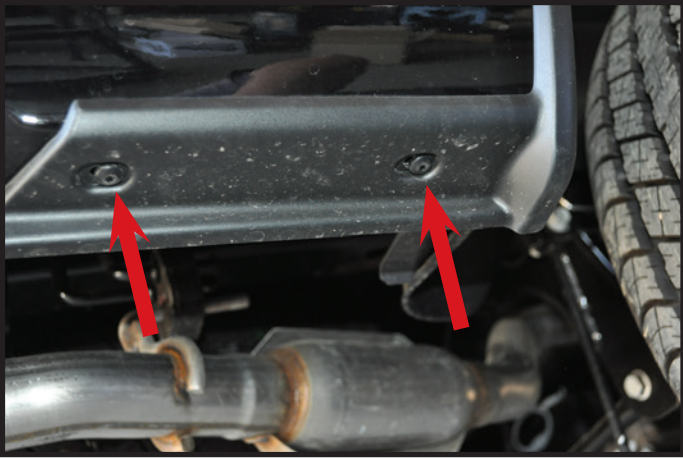

2. Remove two plastic push fasteners from bottom of box as shown in picture. Repeat on other side.

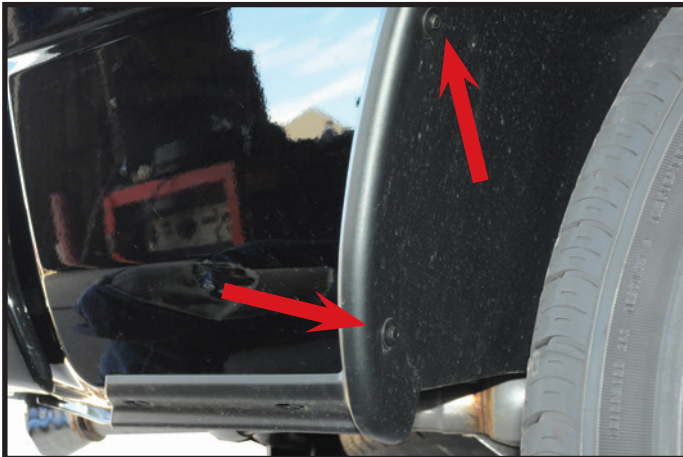

3. Remove two screws from plastic trim behind each wheel as shown.

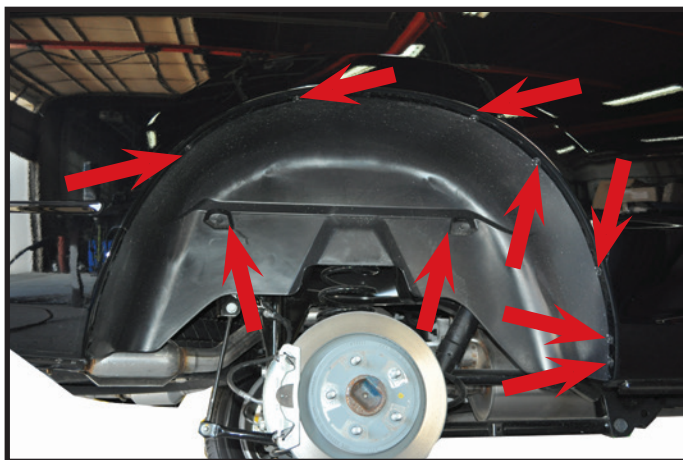

4. Remove remaining nine screws from each wheel well insert.

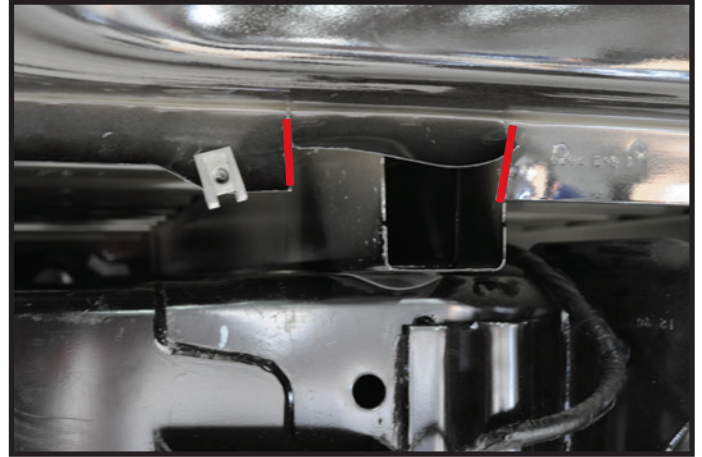

5. Cut flange as shown in each side in picture by box support behind coil spring. **NOTE:** Be careful to not heat up the box paint may discolor in box.

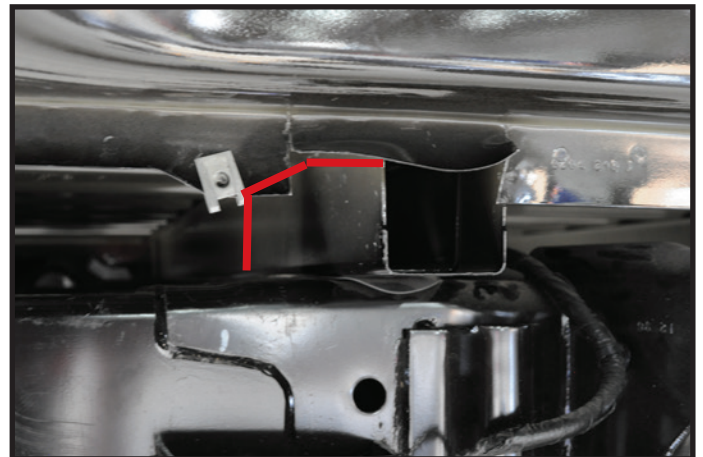

6. On the back side of box support cut along top and 7" in from end and then down. Fold back of support down and make bottom of box flush for clearance for frame bracket.

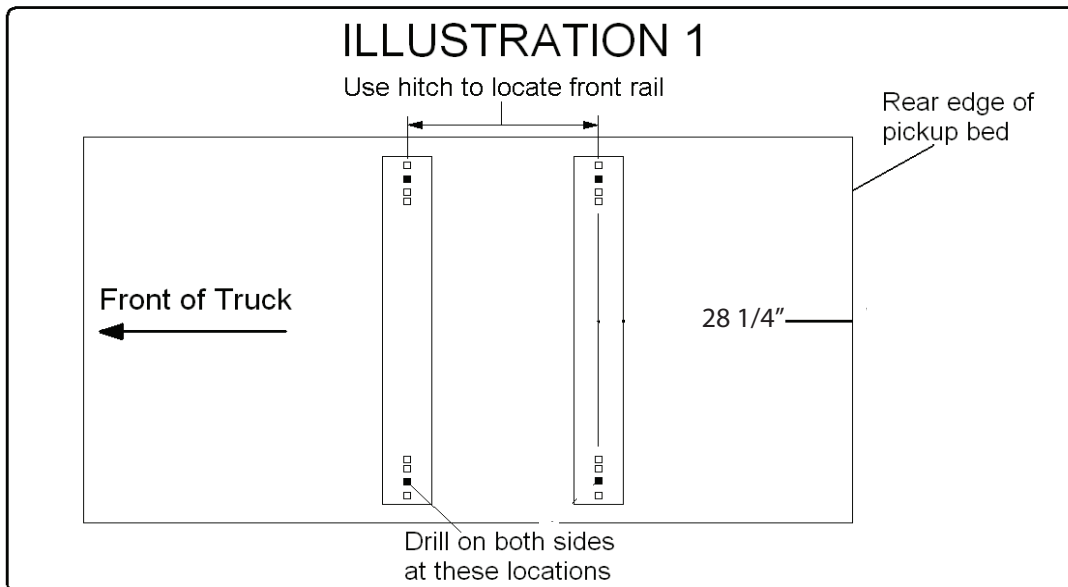

7. Fully assemble the 5th wheel hitch on a flat, level surface and pin into the base rails (assembly instructions come with hitch components). Place assembled hitch in truck bed between the wheel wells, center it side to side and measure 31" from back edge of truck box to the center of back bed rail for 5-1/2' and 6-1/2' boxes.
8. First [check for obstructions under box](#), then drill 3/4" holes thru the second square hole from the end of rails.

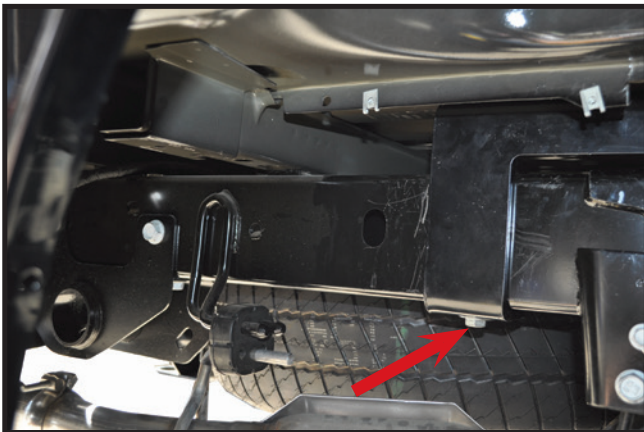

9. Slide rear brackets in to place as shown and bolt using 1/2" x 6" bolt, flat washer, and lock washer. Leave bolts loose. Mount rear bed rail to bracket as shown in bed rail instructions.

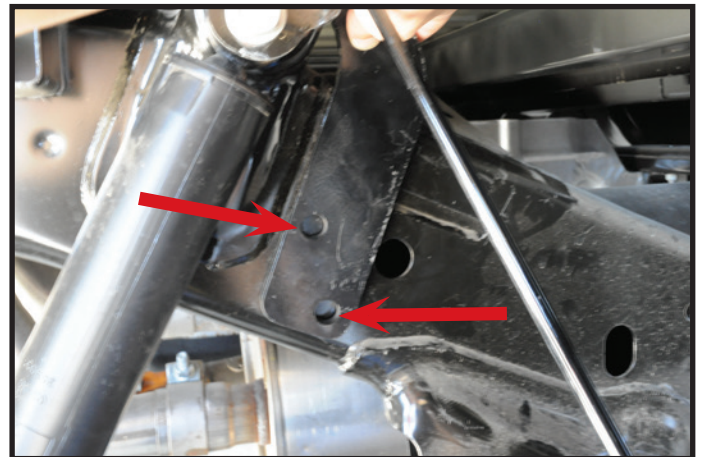

11. Using the holes in the front frame bracket, drill 17/32" holes in the side of the frame. Each of the front frame brackets must be attached using two 1/2" x 1 1/2" hex knurl bolts and flange nuts that are fished through an access hole in the frame using fish wire provided in the kit. Tighten all bolts of front and rear frame bracket according to chart on front page.



10. Slide front frame brackets to outside of frame and mount front bed rail while keeping frame bracket tight to frame. Tighten all bed rail bolts according to chart on front page. Passenger side shown.

12. On drivers side, loosen or remove brace rod so front frame bracket can be installed. If equipped with gas engine, remove wiring holders so frame bracket can lay flat to frame.