

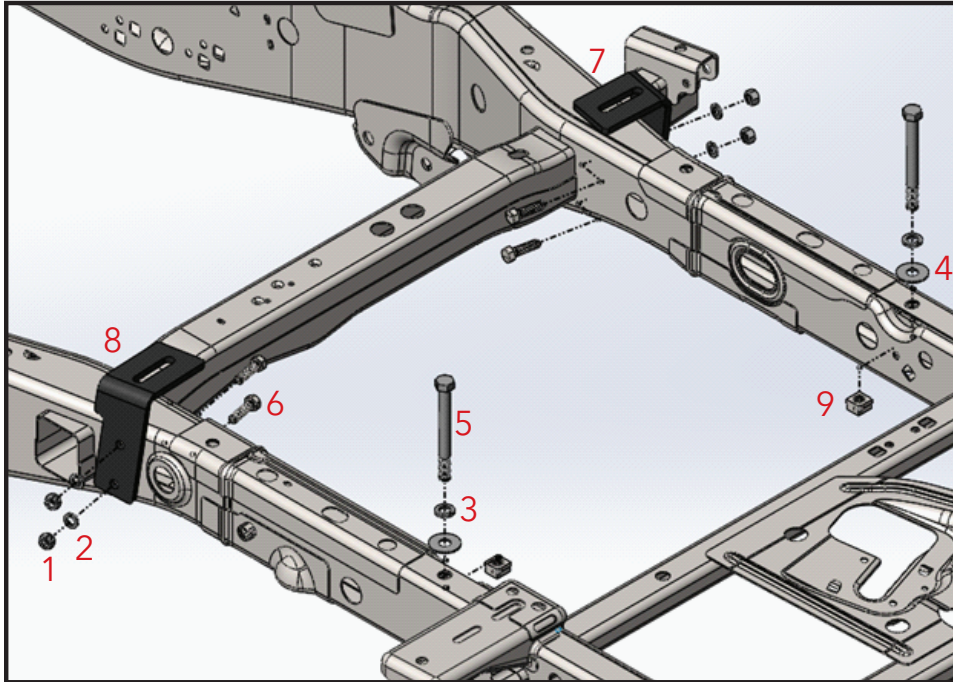

Doing Our Best to Provide You the Best

FRAME BRACKET 8552028

Ford F150 5-1/2', 6-1/2' & 8' Boxes



ITEM	PART #	DESCRIPTION	QTY.
1	00083	NUT, .50 HEX	4
2	00084	WASHER, LOCK .50	4
3	00248	WASHER, LOCK .625	2
4	00477	WASHER, FLAT .625	2
5	01962	BOLT, .625NC X 6 HEX GR.5	2
6	14266	BOLT, .50NC X 1.875 HEX KNURLED GR.5	4
7	15353-76	FRONT PASSENGER BRACKET	1
8	15354-76	FRONT DRIVER BRACKET	1
9	15355-95	NUT, FRAME BRACKET	2
10	14328	FISH WIRE .50 (NOT SHOWN)	1
11	15367	VINYL 5" (NOT SHOWN)	10'

Please order replacement parts by **PART NO.** and **DESCRIPTION.**

OPERATOR MANUAL

Installation

8552028 General Assembly & Installation Instructions

WARRANTY POLICY, OPERATOR MANUALS & REGISTRATION

Go online to review Demco warranty policies, operator manuals and register your Demco product.

BOLT TORQUE SPECIFICATIONS

STANDARD BOLTS			METRIC BOLTS		
Size	Grade	Torque	Size	Grade	Torque
5/16"	5	18 ft/lbs.	8mm	8.8	23 ft/lbs.
3/8"	5	30 ft/lbs.	10mm	8.8	45 ft/lbs.
7/16"	5	50 ft/lbs.	12mm	8.8	78 ft/lbs.
1/2"	5	75 ft/lbs.	14mm	8.8	125 ft/lbs.
5/8"	5	150 ft/lbs.	16mm	8.8	160 ft/lbs.
3/4"	5	290 ft/lbs.			

1. Remove rear inner wheel well inserts if equipped. Temporarily remove brake line manifold assembly bracket to gain access to remove factory nut on driver side. Also, lowering or removing spare tire and heat shield will aid in removing factory nut on passenger side.



2. Inside of the box, remove the middle box bolt on each side using a RIBE 9 or T50 Plus bit (31 1/2" from back of box to center of bolt). **NOTE:** If inside of box has spray in bed liner (factory or after market), liner material must be removed from inside of torx bolt so torx plus bit can fully engage.

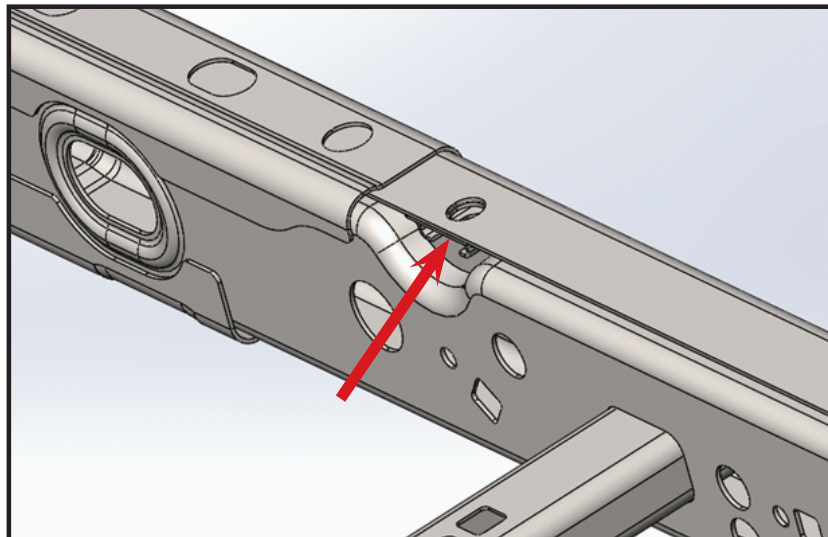

- Remove the factory nut from the frame on each side. Pull down on the nut to get to the retaining leg in the back to slide past and use screw driver to slide the nut out from the frame.

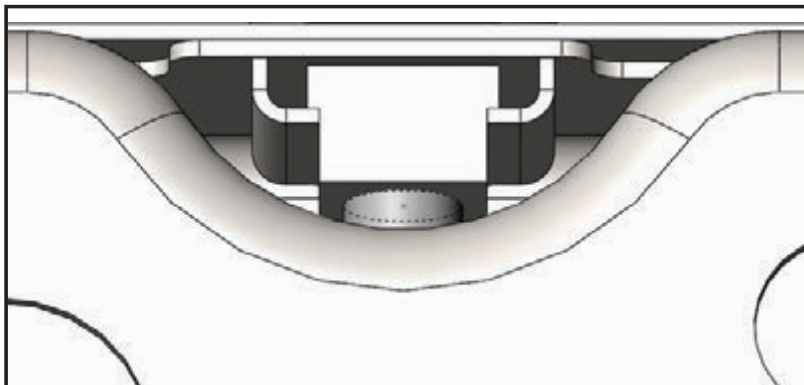

- Slide in the new supplied 5/8" NC T-nut on each side as shown above.
- Apply vinyl to each leg of the rail and box spacer and place them in the box over the factory holes in the box. Using 5/8" x 6" bolts, 5/8" lockwashers and 5/8" flatwashers placed in the third from the outside mounting hole in the rail on each side. Make sure the rail is parallel to the back of the pickup box and tighten according to the chart specifications on the front page. See picture below. **NOTE:** foam applied in picture to show where vinyl is to be applied.

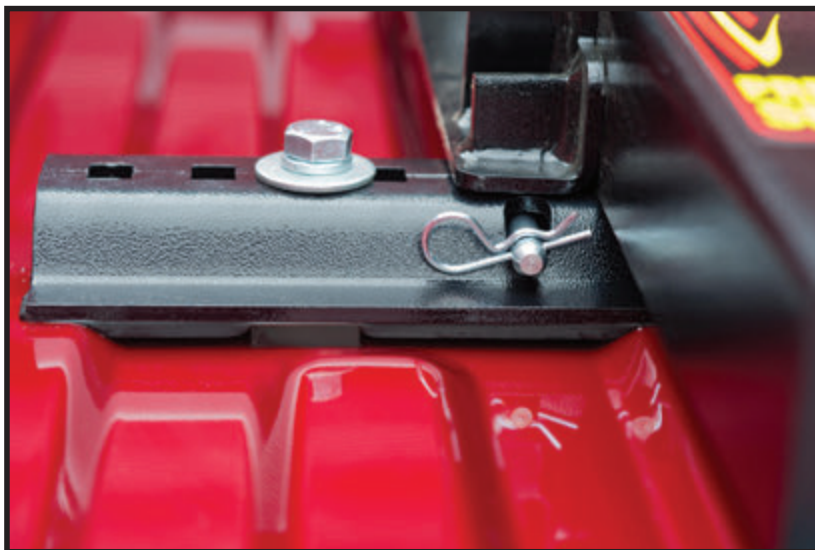

- Apply vinyl to the front rail and box spacers. Place front rail into the box and place the hitch in the rails.
- Make sure the front and rear rails are parallel to each other. Drill a 5/8" hole on each side using the third from the outside mounting hole as a guide (look below the box before drilling to make sure nothing is in the way of the drill bit). Remove the front rail and hitch. Using some paint, touch up the drilled hole to prevent corrosion. Reinstall front rail and hitch. Make sure the rail is once again parallel to the rear rail.

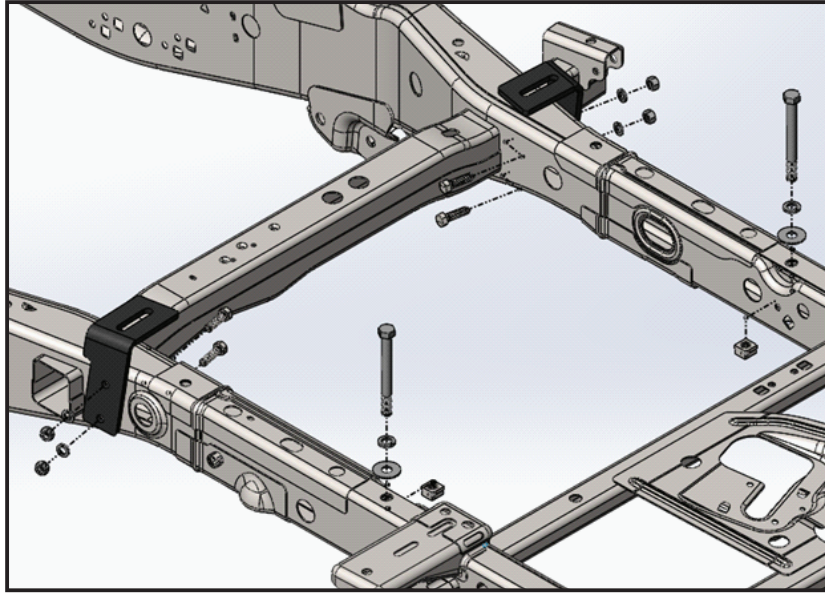

8. On each side, slide the frame bracket onto the frame and up to the bottom of the box. Using the supplied bolts from the 6071 rail kit, install the bolts and tighten to the chart on the front page. **NOTE:** make sure the frame brackets are tight to the frame when tightening the rail bolts.
9. Using the frame bracket as a guide, drill all four holes with a 1/2" drill bit. If desired, use an alignment punch and drill a 1/4" hole first then drill to 1/2".
10. Using the supplied fish wire, install a 1/2" x 1-3/4" knurl bolt in each hole using the hole to the side of each bracket as an access hole. Place a 1/2" lock washer and 1/2" nut on each bolt and tighten according to the chart on the front page.
11. Reinstall the rear wheel well inserts if equipped.

Truck Bed Drilling Instructions with Template

1. Place the template in the box and center the template between the wheel wells.
2. **IF NEEDED, TAPE THE TEMPLATE DOWN.**
3. Measure from the back of the box to the template on the passengers side and drivers side to insure that the template is square. See drawing #1 and table for measurements.
4. Locate which holes you will be drilling, by the ones marked with a red arrow.
5. Take a 3/8" locating punch and mark the holes to be drilled.
6. **BEFORE YOU DRILL, MAKE SURE THAT THE TEMPLATE DID NOT MOVE, AND THAT THERE ARE NO OBSTRUCTIONS IN THE WAY.**
7. Remove the template and drill the four marked holes with a 5/8" drill bit.
NOTE: A pilot hole may need to be drilled.
8. Deburr each hole.
9. Touch up the bare metal with some paint that matches the box of the truck.

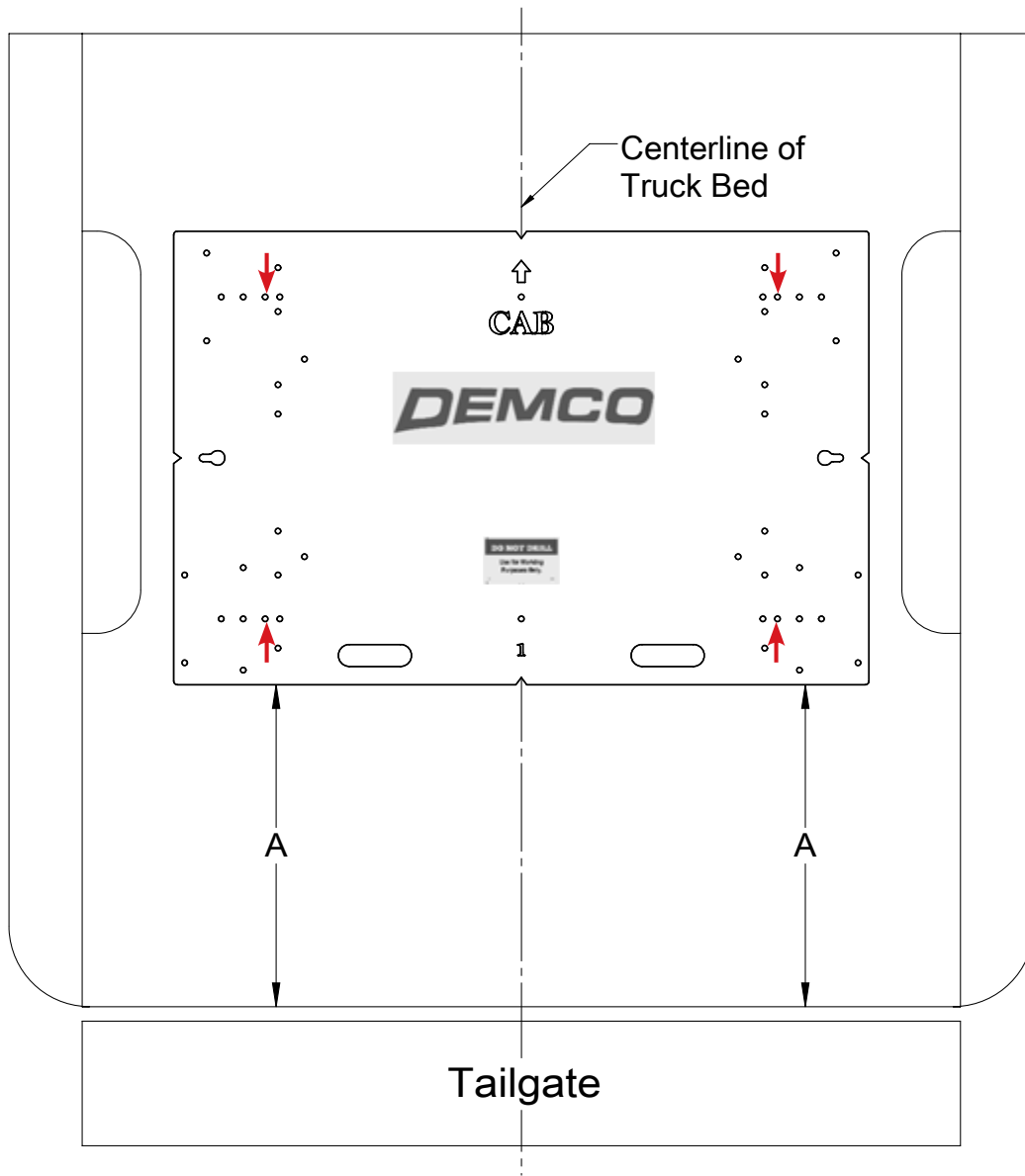

Drawing #1

BOX LENGTH	DIMENSIONS	MEASUREMENT
5-1/2'	A	*27"
6-1/2'	A	*27"
8'	A	27"
*ALL MEASUREMENTS ARE FROM THE BACK OF THE BOX		