



Doing Our Best to Provide You the Best

FRAME BRACKET 8552027

Chevrolet Silverado 1500 & GMC Sierra 1500 (5-1/2', 6-1/2' & 8' Box)

BOLT TORQUE SPECIFICATIONS

STANDARD BOLTS			METRIC BOLTS		
Size	Grade	Torque	Size	Grade	Torque
5/16"	5	18 ft/lbs.	8mm	8.8	23 ft/lbs.
3/8"	5	30 ft/lbs.	10mm	8.8	45 ft/lbs.
7/16"	5	50 ft/lbs.	12mm	8.8	78 ft/lbs.
1/2"	5	75 ft/lbs.	14mm	8.8	125 ft/lbs.
5/8"	5	150 ft/lbs.	16mm	8.8	160 ft/lbs.
3/4"	5	290 ft/lbs.			

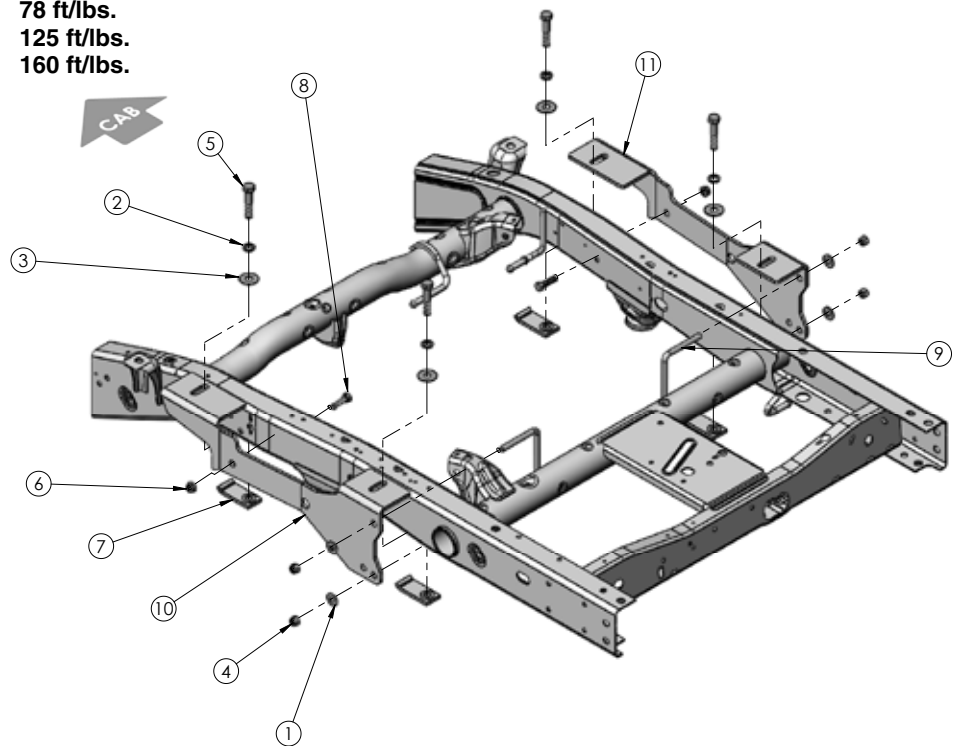

ITEM	PART #	DESCRIPTION	QTY.
1.	00085	1/2" Flat Washer	4
2.	00248	5/8" Lock Washer	4
3.	00477	5/8" Flat Washer	4
4.	02178	1/2" NC Nylon Lock Nut	4
5.	04215	5/8" x 3" Hex Bolt Gr.5	4
6.	10379	1/2" Serrated Flange Nut	2
7.	14251-95	5/8" Tapped Plate	4
8.	14266	1/2" NC x 1 3/4" Hex Bolt Knurled Gr.5	2
9.	14357	1/2" NC x 5 1/2" x 4 1/4" U-Bolt	2
10.	14997-76	Frame Bracket Driver Side	1
11.	14998-76	Frame Bracket Passenger Side	1
12.	14238	1/2" Fish Wire (not shown)	1

Please order replacement parts by PART NO. and DESCRIPTION.

OPERATOR MANUAL

WARRANTY POLICY, OPERATOR MANUALS & REGISTRATION

Go online to review Demco warranty policies, operator manuals and register your Demco product.

Please consult vehicle owner's manual for 5th wheel towing instructions.

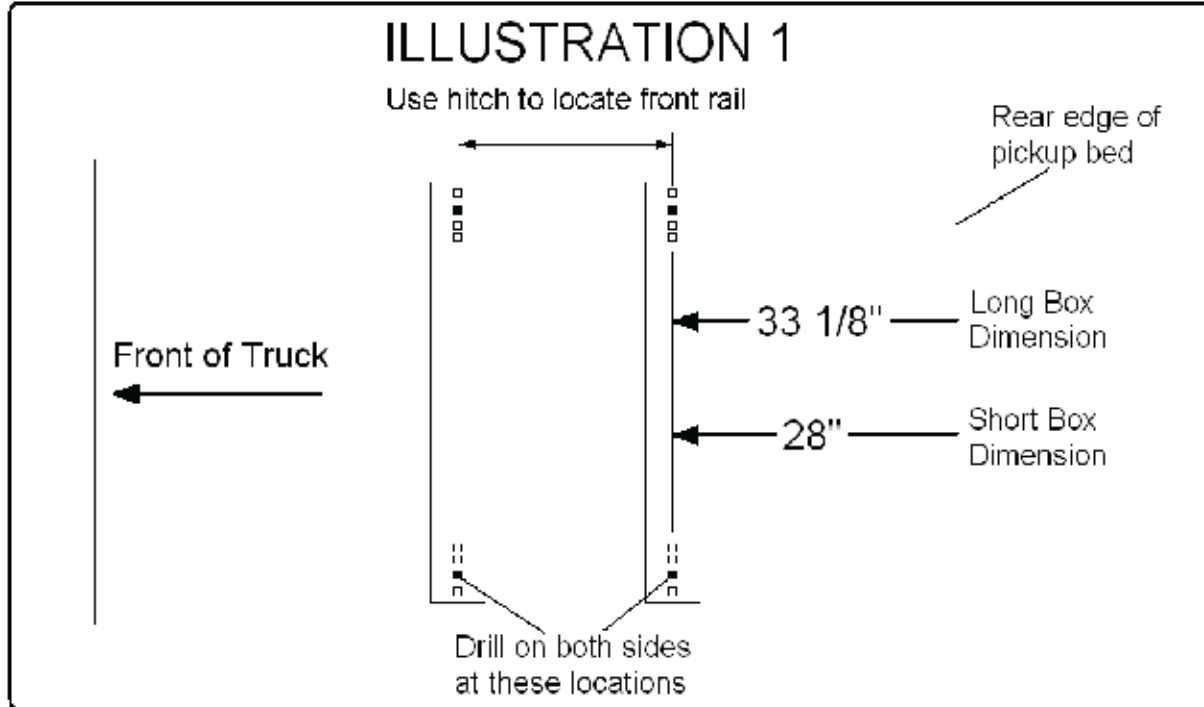

CAUTION: Do not install base rails over plastic bed liners. Plastic bed liners must be cut out of the way. Rails may be installed on spray in liners.

NOTE: Consult spray liner installer for recommended curing time.

1. Fully assemble the 5th wheel hitch on a flat, level surface and pin into the base rails (assembly instructions come with hitch components). Place assembled hitch in truck bed between the wheel wells..
2. Position the base rails in truck bed as shown in Illustration 1 (see above). When hitch is correctly positioned in the bed and the base rails are parallel, check below the bed before drilling holes to see all wiring, brake lines and other obstructions are moved out of the way and will not be contacted by the drill. Start by drilling one hole and place a 5/8" x 3" bolt, 5/8" lock washer and 5/8" flat washer down through the hole after drilling and before drilling next hole. This will help to stop base rails from shifting during drilling.
3. If the bed corrugation above the frame bracket is UP, leaving a space above the frame bracket, place a slotted spacer plate in this location as shown in Illustration 2. If the corrugation is DOWN at this location, place the slotted spacer plate in the bed, under the base rail as shown in Illustration 2a.

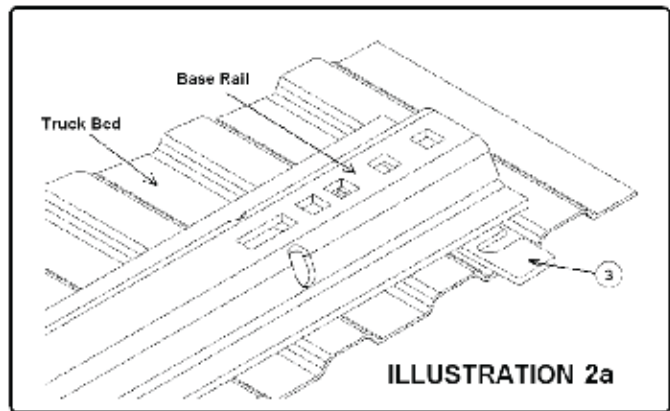
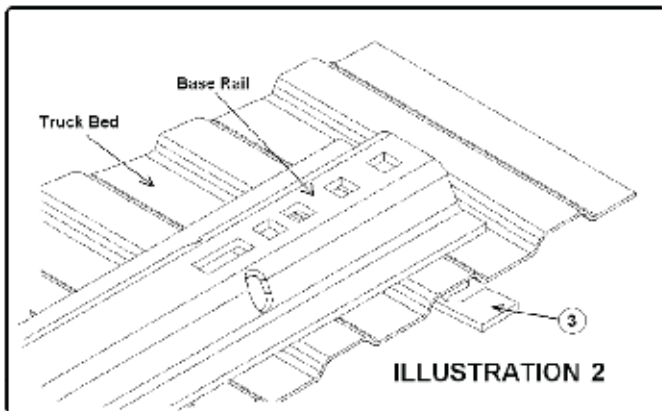

4. Position the left and right frame brackets up against the outer surface of the truck frame with the mounting tabs positioned over the frame and under the bed in line with previously drilled holes in bed where the 5/8" x 3" bolts are coming down through the bed.
5. Make sure the frame brackets are tight against the flat side of truck frame and underneath the surface of the truck bed with bolts extending down through slotted holes in frame bracket tabs. Thread bolts into tapped plates. Position tapped plates with bent portion pointed up towards under side of truck bed and with bent ends of tapped plates towards the tailgate end of truck bed on the forward holes and bent end of the tapped plates on the rear set of holes towards the front or cab end of the truck (see drawing below).
6. Securely bolt the frame brackets into place under the truck bed. Be sure they are tight against the side of the truck frame. Tighten the 5/8" bolts according to the chart on front page.

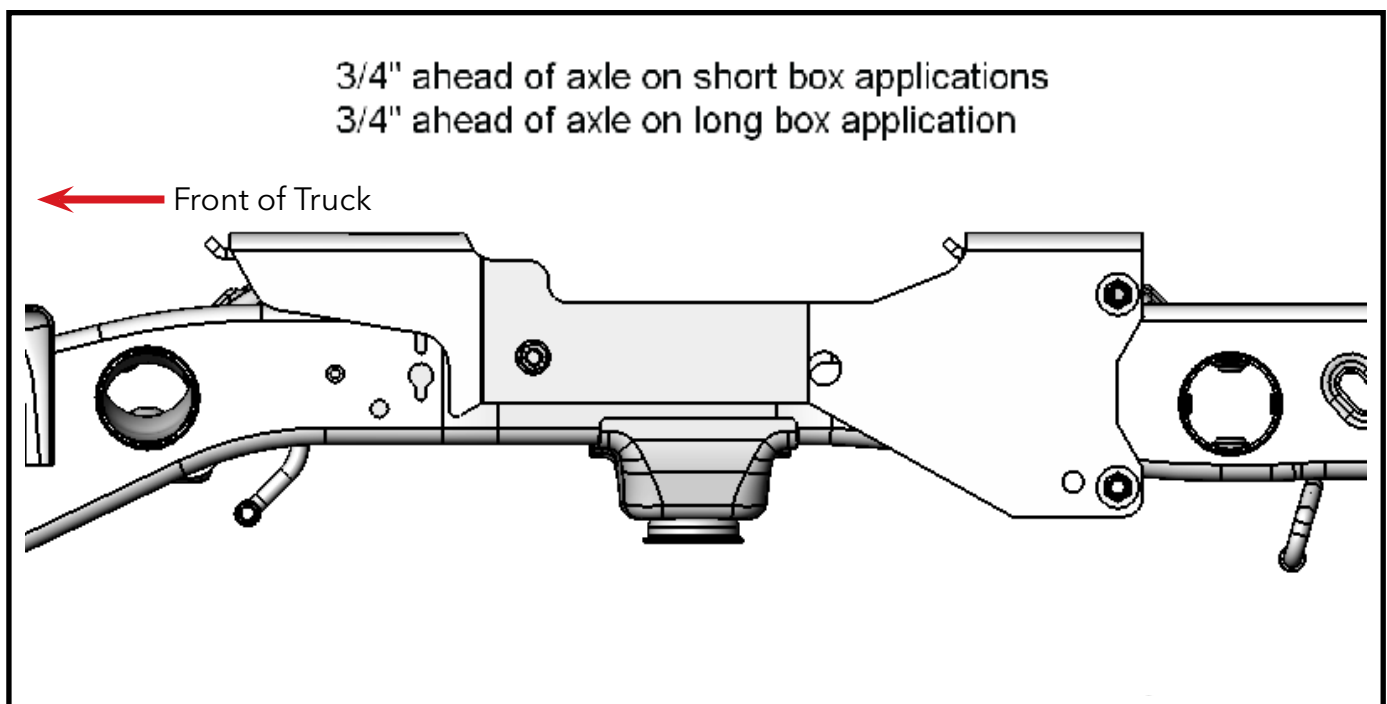

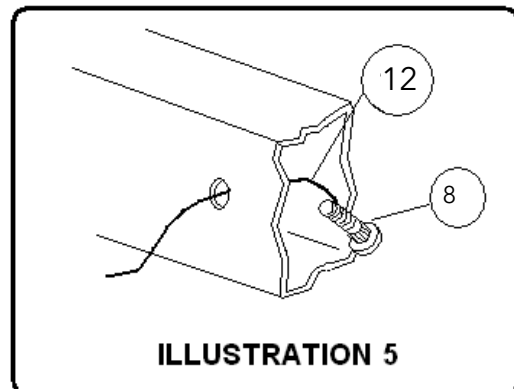
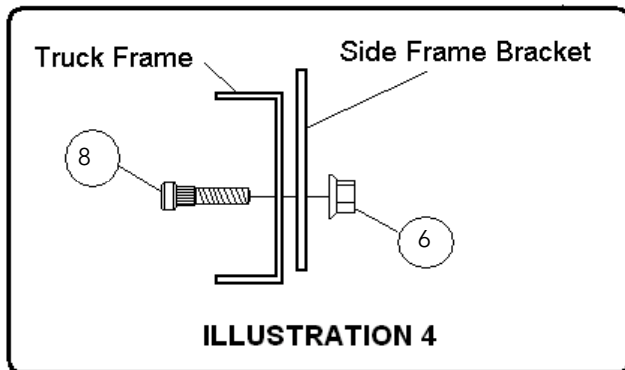
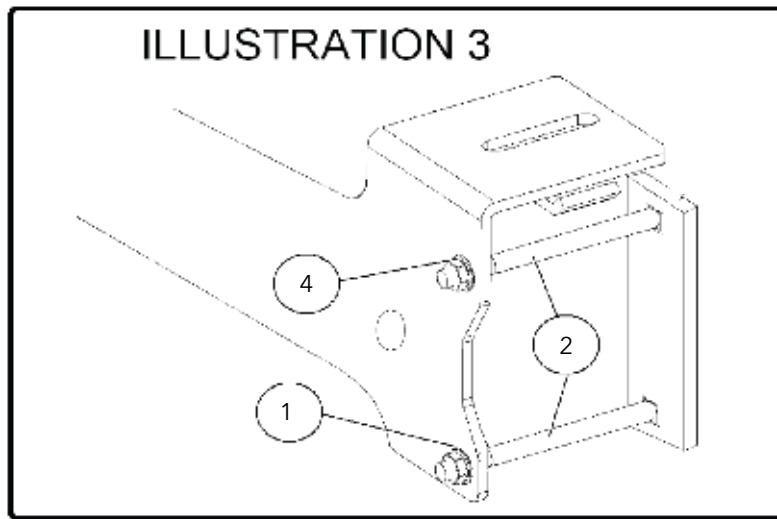

7. Place U-bolts around the truck frame and use 1/2" flat washers and 1/2" nylon lock nuts to attach to frame bracket (see illustration 3). For U-bolts to be used for long box or short box, see below illustration. Be careful to get the driver side U-bolt under the wiring loom and up against the truck frame. **DO NOT PINCH WIRES UNDER THE U-BOLT.**
8. Before drilling any holes in the frame, check the inside of the frame to be sure that there are no wires, brake lines or other obstructions in the frame that may contact the drill. Each of the frame brackets must be attached to the side frame of the truck with a special 1/2" x 1 3/4" knurled bolt at the forward hole and a U-bolt at the rear hole. Be sure frame bracket 1" diameter hole is over large slot in truck frame.
9. At the front attachment point, drill a 17/32" hole through the side of the truck frame using the hole in each frame bracket as a guide. **CAUTION:** Holes MUST be drilled 17/32" diameter, so that the special knurl bolts will seat properly. If the holes are too small, the bolt may break. If the holes are too large, it will not grip properly.
10. Place the knurl bolt into the frame first through the 1" hole in bracket and then out through the drilled hole at the front of the frame brackets (see illustration 4). Thread the fish wire over the end of the knurl bolt and pull through the frame and frame bracket (see illustration 5). Secure each bracket to the truck frame. The knurled portion of the bolts will lock into the frame holes as the nuts are tightened. Use of an air wrench will make installation easier.
11. Tighten all bolts according to chart on front page. Failure to tighten bolts as described may result in fastener loss or failure.

DEMCO

