



DODGE
3500 4x2 & 4x4
6 1/2' & 8' Box
includes Mega Cab

7/16
HJ32026, Rev 3



BOLT TORQUE SPECIFICATIONS

STANDARD BOLTS			METRIC BOLTS		
Size	Grade	Torque	Size	Grade	Torque
5/16"	5	18 ft/lbs.	8mm	8.8	23 ft/lbs.
3/8"	5	30 ft/lbs.	10mm	8.8	45 ft/lbs.
7/16"	5	50 ft/lbs.	12mm	8.8	78 ft/lbs.
1/2"	5	75 ft/lbs.	14mm	8.8	125 ft/lbs.
5/8"	5	150 ft/lbs.			
3/4"	5	290 ft/lbs.			

FRAME BRACKET

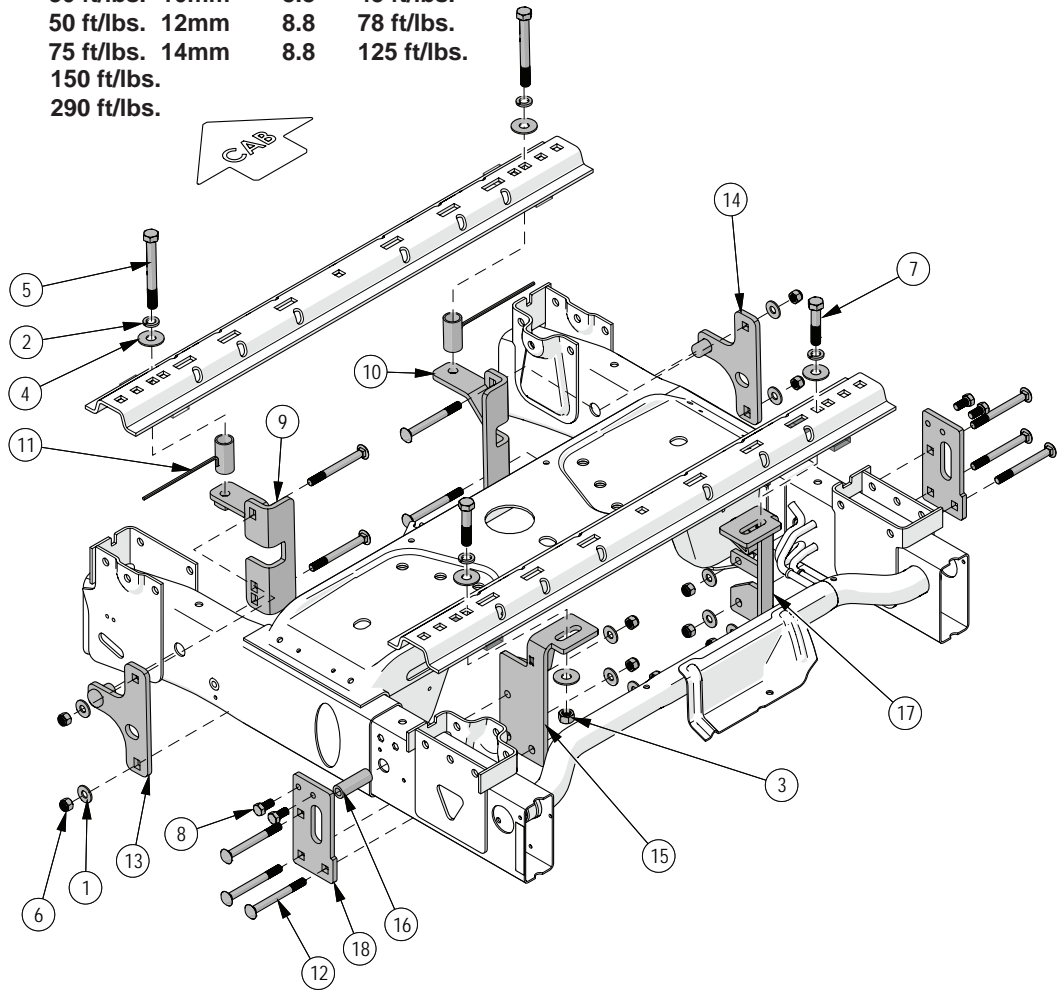

8552026 PARTS LIST

ITEM	PART #	DESCRIPTION	QTY.
1	00085	.50 FLAT WASHER	10
2	00248	WASHER SPRING LOCK 0.625	4
3	00291	.625NC HEX NUT	2
4	00477	WASHER, FLAT, .625	6
5	00943	BOLT, .625NC X 5.50 GR5 HEX	2
6	02178	NUT, .50NC LOCK, NY. INSERT	10
7	04215	BOLT, .625NC X 3.00 GR5 HEX	2
8	04795	BOLT, .50 NC X 1.00 HEX HD GR.5	4
9	14304-76	FRONT LEFT INNER BRKT	1

Please order replacement parts by PART NO. and DESCRIPTION.

ITEM	PART #	DESCRIPTION	QTY.
10	14305-76	FRONT RIGHT INNER BRKT	1
11	14367-76	SPACER TUBE	2
12	14376	BOLT .50NC X 5.00 GR5 CARRIAGE	10
13	14726-76	BRACKET	1
14	14727-76	BRACKET	1
15	14730-76	REAR INSIDE BRACKET	1
16	14732	BUSHING	2
17	14875-76	REAR INNER BRACKET	1
18	15784-76	REAR OUTER PLATE	2
19	14577-76	SPACER PLATE (not shown)	4

Please order replacement parts by PART NO. and DESCRIPTION.

ASSEMBLY
OPERATION
REPLACEMENT PARTS

READ complete manual CAREFULLY
BEFORE attempting operation.

Doing Our Best to Provide You the Best

CAUTION: Do not install base rails over plastic bed liners. Plastic bed liners must be cut out of the way. Rails may be installed on spray in liners.

NOTE: Consult spray liner installer for recommended curing time.

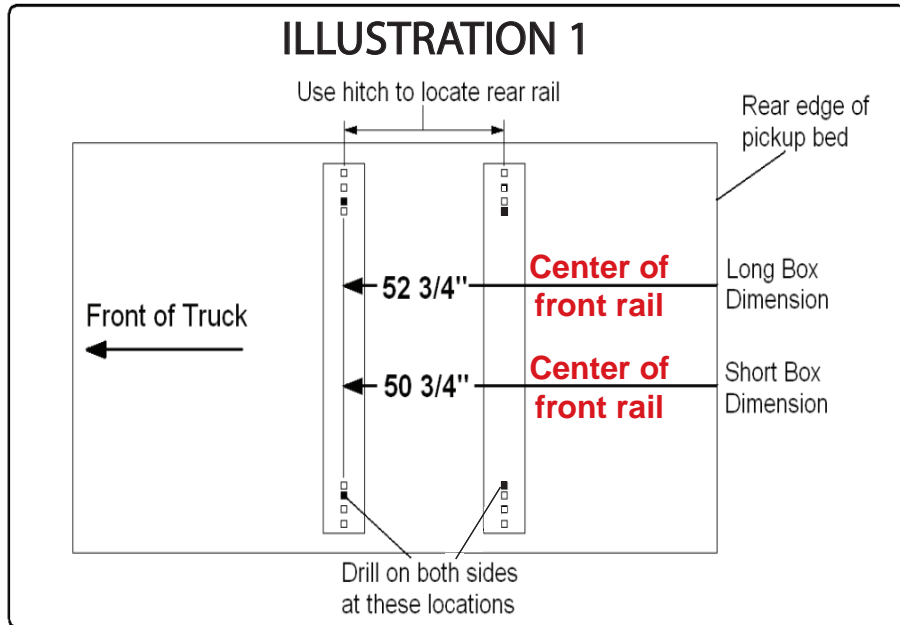

1. On the inside of the left vehicle frame is a wiring harness that is held in place with plastic clips. This section of wiring harness must be moved aside by removing plastic clips from frame. This will allow the hitch parts to be positioned correctly on frame.
2. Fully assemble the 5th wheel hitch on a flat, level surface and pin into the base rails (assembly instructions come with the hitch components). Place assembled hitch in truck bed between the wheel wells.
3. Position the base rails in truck bed as shown in **Illustration 1**. Be sure the base rails are parallel by measuring diagonally as shown in **Illustration 1A**.

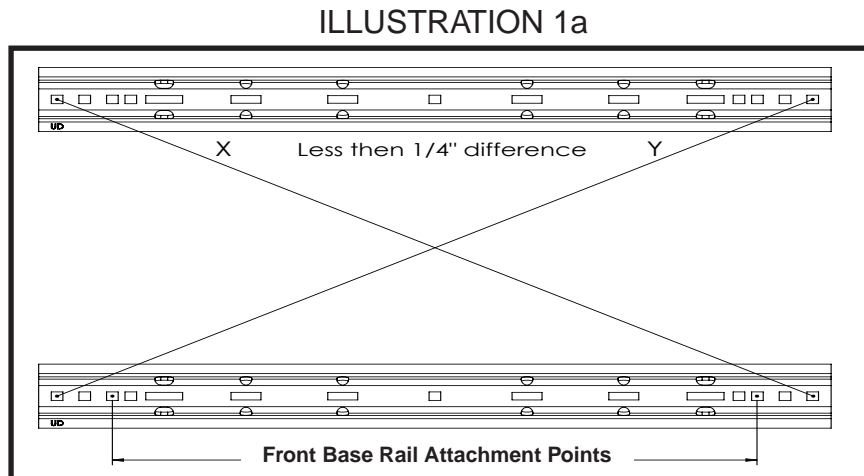

4. Make two attachment points on the truck bed using the square holes in the front base rail as shown in **Illustration 1**. **NOTE: Mark center of square bolt hole.**

DO NOT mark the rear base rails at this time. Check below the bed before drilling holes to see that all wiring, brake lines or other obstructions are moved out of the way and will not be contacted by the drill. Drill 1/4" diameter pilot holes down through the bed and hat section at the previously marked points. Be certain that the holes are drilled in the correct location. They must be drilled through the under bed hat section.

5. Position the left & right front outer brackets (#14726-76) & (#14727-76) against their respective truck frames so that the pin in each bracket aligns with the existing hole in the side of the vehicle frame. **NOTE:** There may be a wire hanger bracket bolted to the frame at the location which will not allow the front frame bracket to be installed. This wire bracket will have to be removed from the frame so that the frame bracket can be installed.
6. Bolt the left & right front outer brackets (#14726-76) & (#14727-76) to the frame with the inner brackets (#14304-76) & (#14305-76). Take care when positioning the left inner bracket (#14304-76) so that the slot in bracket fits over the steel brake line.
7. Position the base rails in the bed so that the third square 5/8"

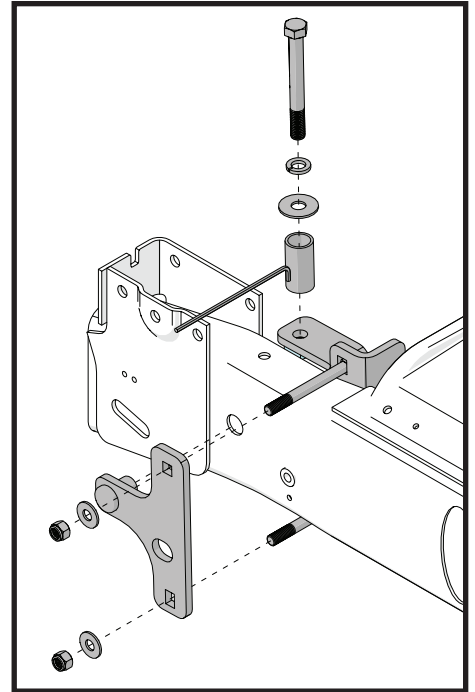

See **illustration 3a**. Use the carriage bolts (#14376) at both bracket attachments. Slide bracket (#14304-76) rearward away from the gas tank so long bolt can be installed. Then slide bracket forward into position. Use the lower hole in each bracket. Bolts must be as close to bottom of truck frame as possible. The tab on the inner bracket should be against the bottom of the bed support hat section. The hole in the tab should be aligned with the previously drilled 1/4" pilot hole.

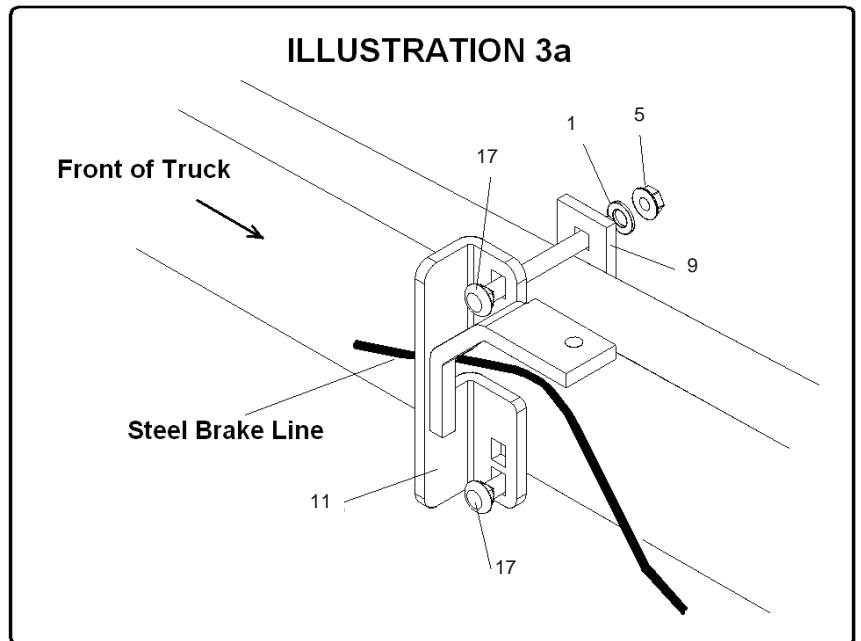

hole in from the end of the front rail is lined up over the previously drilled pilot holes. Double check that the pilot holes line up with holes in base rail and the tab on frame brackets under the bed. Move base rails away from pilot holes and drill a 3/4" hole down through truck bed at each previously drilled pilot holes. The 3/4" hole will give some tolerance to get the bolt down into the tapped bracket hole. **Use caution when drilling so that the drill does not make contact with the installed brackets or fuel tank under bed.** **NOTE:** For alternative installation procedures refer to the last page of this document.

8. Place a 3/4" thick spacer plate under ends of each base rail, in line with drilled holes as shown in **Illustration 4**. If the bed corrugation above the mounting bracket at the drilled hole is UP, leaving a space above the bracket, place spacer plate in this location as shown in **Illustration 5**. If the corrugation is DOWN, at this location, place a spacer plate in the bed under the base rail as shown in **Illustration 5a**.

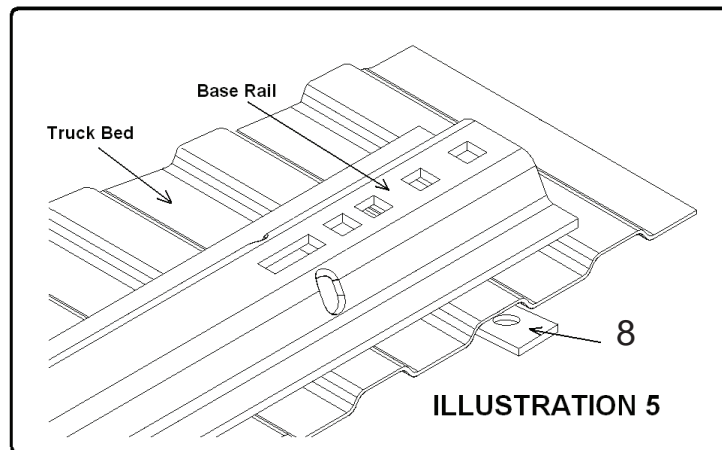
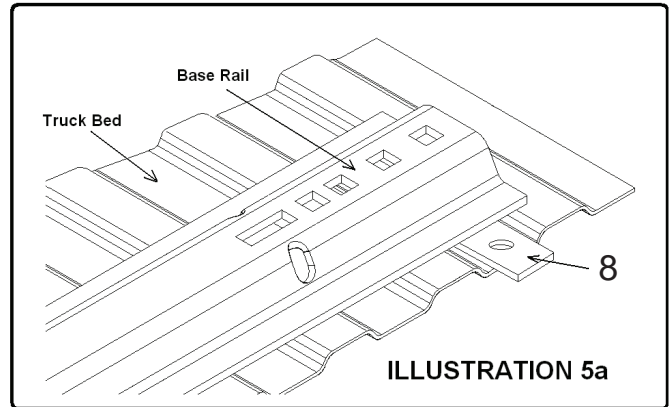
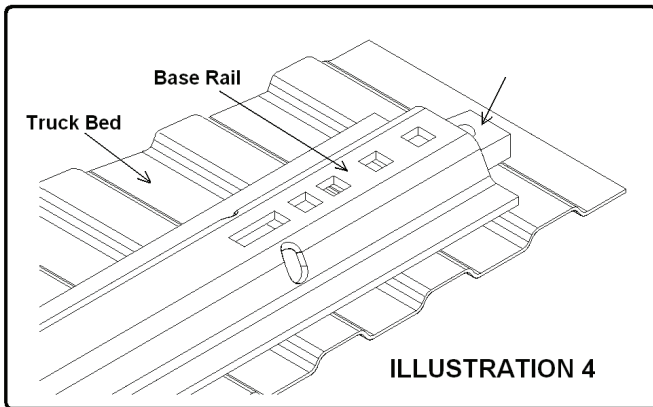

9. Slide tube spacers (#14367-76) into the forward bed support hat section from the open end in each wheel well. **NOTE:** On some applications a small sheet metal flange may appear to obstruct placement of the spacer tube. This flange can be modified to gain access to the hat section. See detail for this procedure in **Illustration 6**.

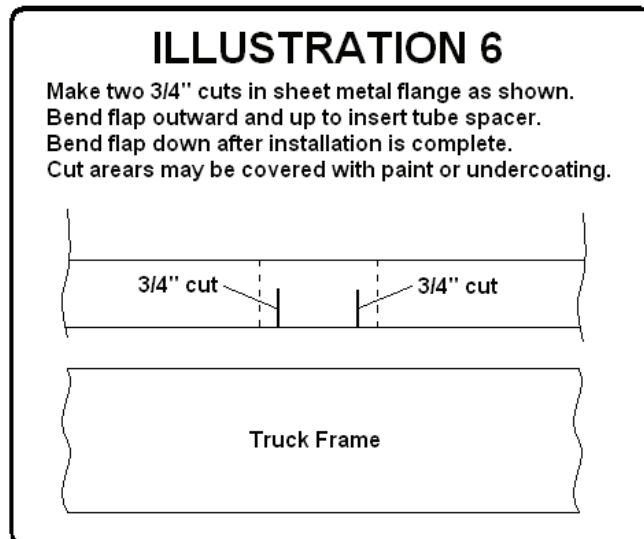

10. On left side of truck, align the tube spacer with drilled hole and insert 5/8" x 5 1/2" bolt (#00943) with 5/8" flat washer (#00477) and 5/8" lock washer (#00248) down through all parts and mounting brackets. See **Illustration 6a**. Thread bolt into tapped plate on left front inner bracket (#14304-76). Repeat procedure on right side of truck base rail using 5/8" flat washer and 5/8" lock washer as shown in **Illustration 6b**. Tighten the 5/8" bolts to specified torque on front page.

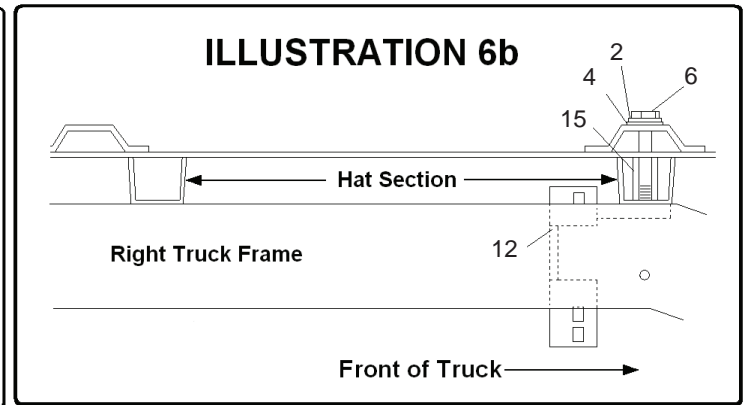
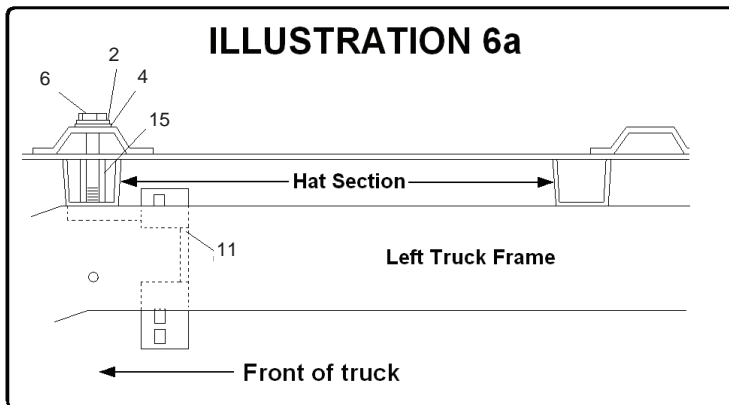

11. Mark the rear hole locations using the rear base rails as shown in **Illustration 1**. Drill a 5/8" hole down through bed using the fourth hole in from each end of rear base rail as a guide as shown in **Illustration 1**.
12. Place spacer plates under base rails as described in step 8. Place 5/8" x 3" bolts (#04215) with 5/8" flat washer (#00477) down through base rail, spacer plates & truck bed at drilled holes.
13. Place the left inner (#14730-76) & left outer (#15784-76) mounting bracket up in place against the inside and outside surface of the truck frame just behind the under bed hat section reinforcement. See break down on front page. Repeat on passenger side using right inner (#14875-76) & right outer (#15784-76) frame brackets. The previously installed 5/8" bolts should go through the upper tab in each bracket. Bolt the brackets loosely in place at these bolts with 5/8" flat washer (#00477), 5/8" lock washer (#00248) and 5/8" hex nuts (#00291). **NOTE: Some models that have "Auto Level Rear Air Suspension" will need to have two 1/2" bolts removed from (#15784-76) both sides. Remove two factory 8mm bolts from leveling bracket and laminate over top of above (#15784-76) and reinstall factory bolts.**

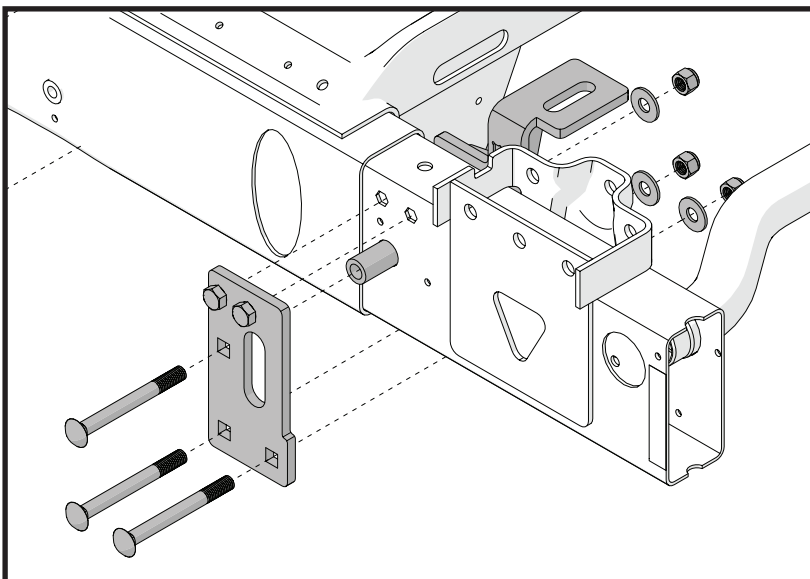

14. Secure the left & right inner & left & right outer mounting brackets in place with 1/2" x 5" Gr.5 carriage bolts (#14376), 1/2" flat washers (#00085) and 1/2" nylon lock nuts (#02178) place through square hole in outer brackets. Bolts must be as close to bottom of truck frame as possible.
15. Tighten all bolts to chart on front page. **NOTE:** After the bolts are installed & torque to the specifications in the chart on the front page, the lower bolts may need to be trimmed off to clear suspension parts.

Alternative Installation Procedure

BE SURE TO ADVISE CUSTOMER ABOUT THE LARGE HOLES THAT WILL BE CUT INTO BED BEFORE BEGINNING THIS INSTALLATION.

1. Cut a 1-1/4" hole down through the bed at pilot hole location. This hole must only be cut through bed of truck, not through bottom of the hat section under the bed.
2. Drill a 5/8" hole through bottom of the hat section under the bed at the previously drilled pilot hole.
3. Remove the wire handle from the spacer tube (#14367-76). Insert the spacer tube down through the hole in the bed so that it will rest on the under bed hat section in line with the previously drilled 5/8" hole.
4. With the front base rail in place, insert a 5/8" x 5-1/2" hex bolt (#14357) down through the base rail, tube spacer and frame bracket tab. Bolt securely in place at this location.
5. Repeat procedure on the other end of front base rail.
6. Continue with step 8 of main instructions.

