



Ford F150  
5 1/2', 6 1/2' \* 8' Boxes

10/17  
HJ33015, Rev 4



**BOLT TORQUE SPECIFICATIONS**

STANDARD BOLTS			METRIC BOLTS		
Size	Grade	Torque	Size	Grade	Torque
5/16"	5	18 ft/lbs.	8mm	8.8	23 ft/lbs.
3/8"	5	30 ft/lbs.	10mm	8.8	45 ft/lbs.
7/16"	5	50 ft/lbs.	12mm	8.8	78 ft/lbs.
1/2"	5	75 ft/lbs.	14mm	8.8	125 ft/lbs.
5/8"	5	150 ft/lbs.			
3/4"	5	290 ft/lbs.			

# FRAME BRACKET

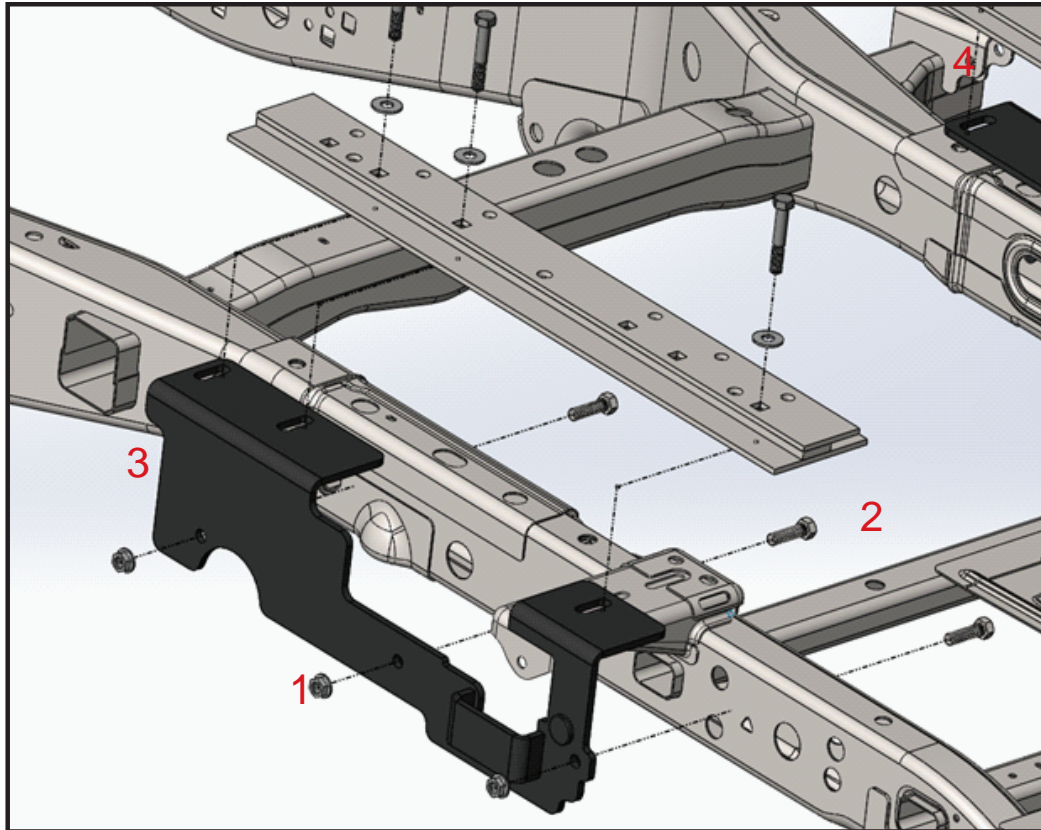

**8553015 PARTS LIST**

ITEM	PART #	QTY	DESCRIPTION
1	10379	6	.50 SERRATED FLANGE NUT
2	14266	6	.50 NC X 1.75 HEX BOLT SERRATED NECK GR.5
3	14365-76	1	DRIVER SIDE FRAME BRACKET
4	14366-76	1	PASSENGER SIDE FRAME BRACKET
5	14238	1	.50 FISH WIRE (NOT SHOWN)
6	15367	13'	VINYL 5" (NOT SHOWN)

Please order replacement parts by **PART NO.** and **DESCRIPTION**

ASSEMBLY  
OPERATION  
REPLACEMENT PARTS

**READ** complete manual CAREFULLY  
BEFORE attempting operation.

Doing Our Best to Provide You the Best

**CAUTION:** Do not install base rails over plastic bed liners. Plastic bed liners must be cut out of the way. Rails may be installed on spray in liners.

**NOTE:** Consult spray liner installer for recommended curing time.

**NOTE:** All metal surfaces that come in contact the aluminum body need to have vinyl placed in between to prevent corrosion.

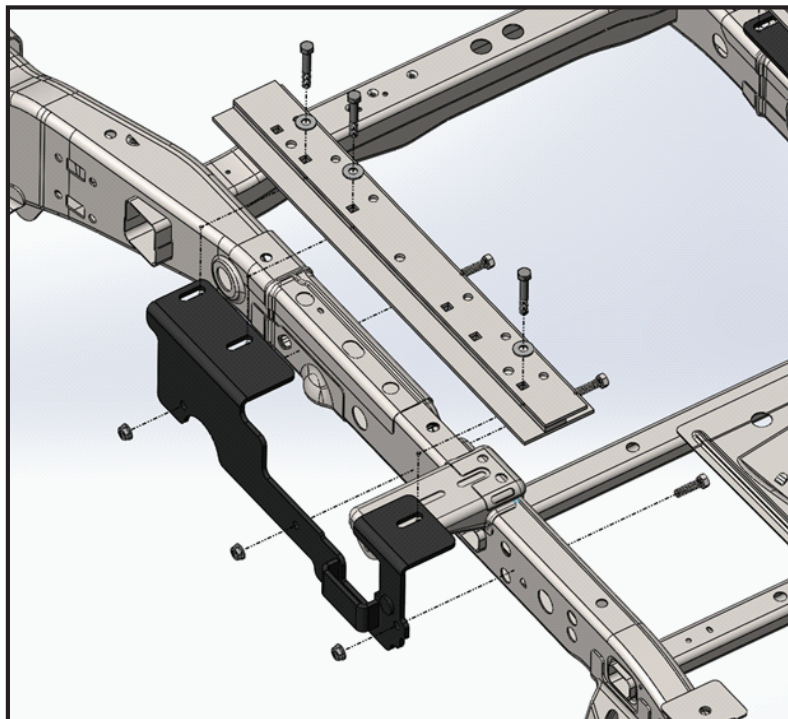

## INSTALLATION

1. a. Completely assemble hitch. See GENERAL INSTRUCTIONS and SAFETY supplied. Apply vinyl to bottom of rails & shims.  
b. Set hitch into back of truck, center it side to side.  
c. Measure 20" from back edge of truck box to back edge of bed rail.
2. Check underneath box at bolt hole locations for any obstructions (frame members, etc.).
3. a. Drill two 17/32" holes thru HOLE #2, each bed rail.  
b. Insert two 1/2" x 3" (04073) long hex bolts.  
c. Drill thru HOLES #3 and #6, each bed rail. Insert four 1/2" x 3" hex bolts (04073).
4. a. Under box, place (15365-76 & 15366-76) frame brackets onto hex bolts (six places). Apply vinyl to top of brackets where they touch the box. **NOTE:** Frame welds may need to be ground for a tight flush fit to the frame. Paint ground area and let cure, then proceed.  
b. Loosely install frame washer (14235-95), 1/2" flat washer (00085), and 1/2" Nylon lock nut (02178).  
c. Press each bracket tight against frame member, tighten nuts snug against box.
5. a. Pilot drill\* and drill 1/2" hole into truck frame (one wall), at three places thru holes in each frame bracket -- BE CAREFUL OF ELECTRIC OR FLUID LINES behind frame members.  
b. Fasten brackets with 1/2" x 1 3/4" (14266) knurl bolts using fish wire through holes on inside of frame and serrated nuts (10379).  
c. TIGHTEN ALL BOLTS ACCORDING TO CHART ON FRONT PAGE.

\* To pilot drill: Use 1/2" drill bit or transfer punch to mark center. Drill thru with 1/4" drill.

*Demco*