



Chevrolet/GMC  
1500

**BOLT TORQUE SPECIFICATIONS**

STANDARD BOLTS			METRIC BOLTS		
Size	Grade	Torque	Size	Grade	Torque
5/16"	5	18 ft/lbs.	8mm	8.8	23 ft/lbs.
3/8"	5	30 ft/lbs.	10mm	8.8	45 ft/lbs.
7/16"	5	50 ft/lbs.	12mm	8.8	78 ft/lbs.
1/2"	5	75 ft/lbs.	14mm	8.8	125 ft/lbs.
5/8"	5	150 ft/lbs.	16mm	8.8	160 ft/lbs.
3/4"	5	290 ft/lbs.			

# FRAME BRACKET

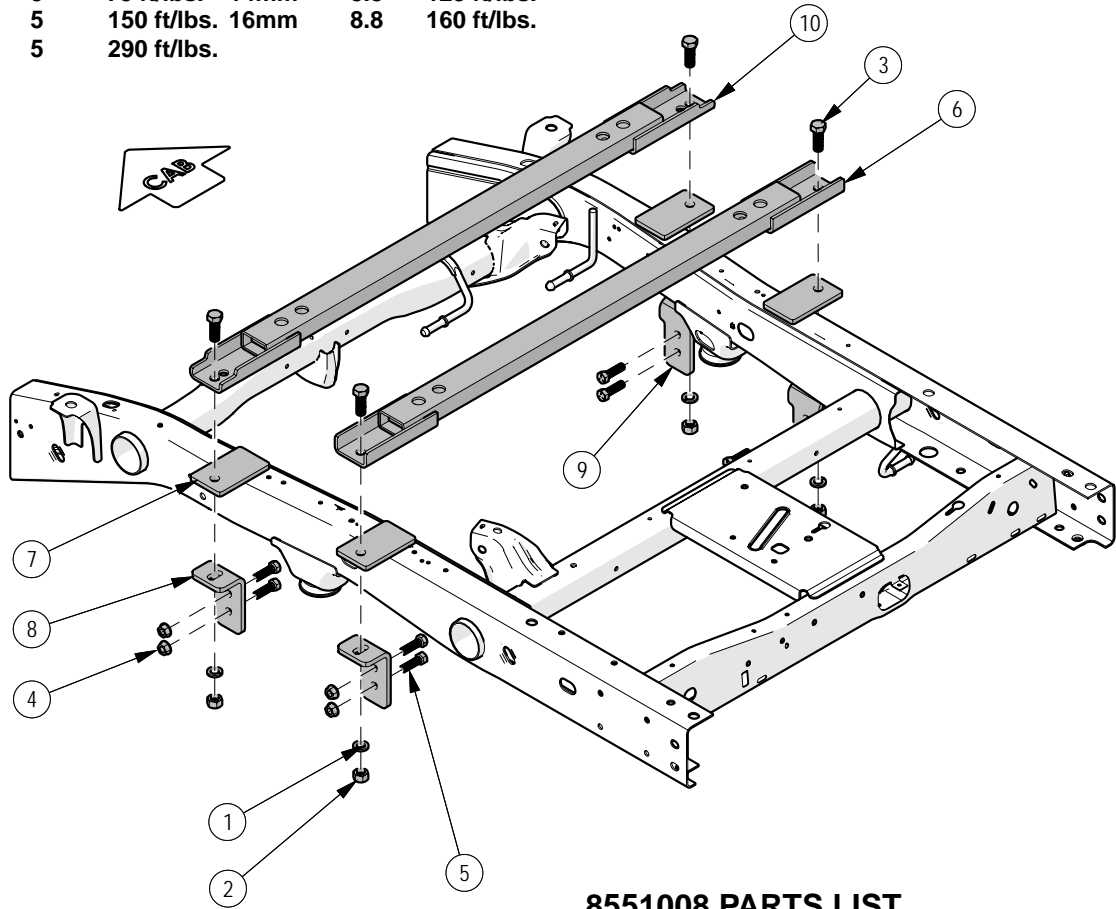

**8551008 PARTS LIST**

ITEM	PART #	QTY	DESCRIPTION
1	00248	4	WASHER SPRING LOCK 0.625
2	00291	4	.625NC HEX NUT
3	00290	4	BOLT .625NC X 2 GR5 HEX
4	10379	8	1/2" SERRATED FLANGE NUT
5	14266	8	BOLT, .50 NC X 1.75 GR5 HEX W/ KNURLED
6	14267-76	1	STANDARD UMS BASE RAIL
7	14275-76	4	UM BASE RAIL SHIM, .375 THK
8	14995-76	2	ANGLE BRACKET DRIVER SIDE
9	14996-76	2	ANGLE BRACKET PASSENGER SIDE
10	15783-76	1	WIDE UMS BASE RAIL (front)
-	14238	1	1/2" FISH WIRE (not shown)
-	14225	4	CAP PLUG (not shown)

Please order replacement parts by PART NO. and DESCRIPTION.

ASSEMBLY  
OPERATION  
REPLACEMENT PARTS

**READ** complete manual CAREFULLY  
BEFORE attempting operation.

Doing Our Best to Provide You the Best

# **8551008 General Assembly and Install Instructions**

## **Hitch Assembly:**

1. Place the base rails on a flat level surface. Insert and lock the side rail plates into the base rail holes as shown in the supplied hitch instructions.
2. Loosely bolt the saddle bracket and the two cross brackets to the side rails using the fasteners provided with the hitch.
3. Tighten all bolts according to the chart on front page.
4. Unlock and remove the hitch assembly from the base rails and put to the side for later.

## **Truck Bed Drilling Instructions:**

**NOTE:** It may make the install easier if the truck's rear end was lifted and blocked and/or remove the rear wheels to have more access for drilling of the frame. Some later years have inner wheel well liners, these maybe removed to help with installation.

The four 2" holes that need to be drilled through the box are done by the following method:

1. Use the measurements shown in (drawing #1) to mark out the four holes that will be drilled through the truck bed.
2. Start out by measuring 31 3/4" for 5-1/2' & 6-1/2' box and 36 1/4" for 8' box from the end of the bottom of the truck bed (tailgate end) to a point on the left side of center of the bed and mark it. Do the same on the right side of center of the bed and mark it. Draw a line across the bed using these two marks as a reference.
3. Measure out and find the center of the truck bed and draw a line from the front to the rear of the bed.
4. Measure out 14-13/16" to either side of the middle center line slightly ahead of the fender well and slightly behind the fender well.
5. Draw a line between these two points. Do the same on the other side.
6. Measure out (towards the cab) 13-1/2" from the points where the line that goes across the bed intersects with the two lines that are 14-13/16" off the center running the length of the bed. Mark these two points.
7. There should now be four spots marked out for drilling. Double check that the rear hole marks are exactly 31 3/4" for 5-1/2' & 6-1/2' box and 36 1/4" for 8' box from the end of the bed and that the front holes marks are exactly 13-1/2" forward of those marks.
8. Check the hole marks from side to side and make sure they are exactly 29-5/8" apart from each other.
9. Finally, check for square by measuring diagonally from opposite corners (drawing #2). The measurement should be the same both ways. It should measure 32-9/16".
10. After all the hole marks have been double checked for proper placement, use a center punch and hammer to mark out the spots for drilling.
11. Drill the holes using a 2" hole saw. Deburr the holes using a small file and apply some touch up paint to match color (not supplied).

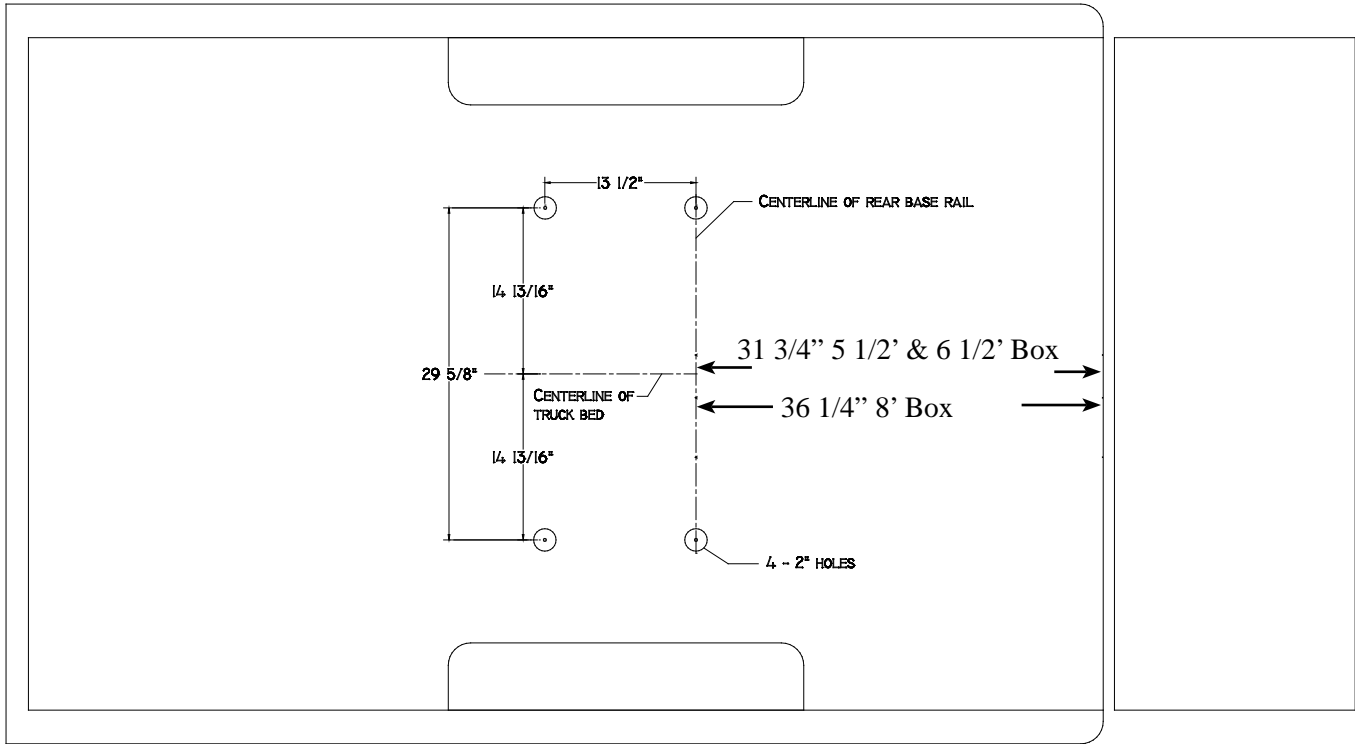

**Drawing #1**

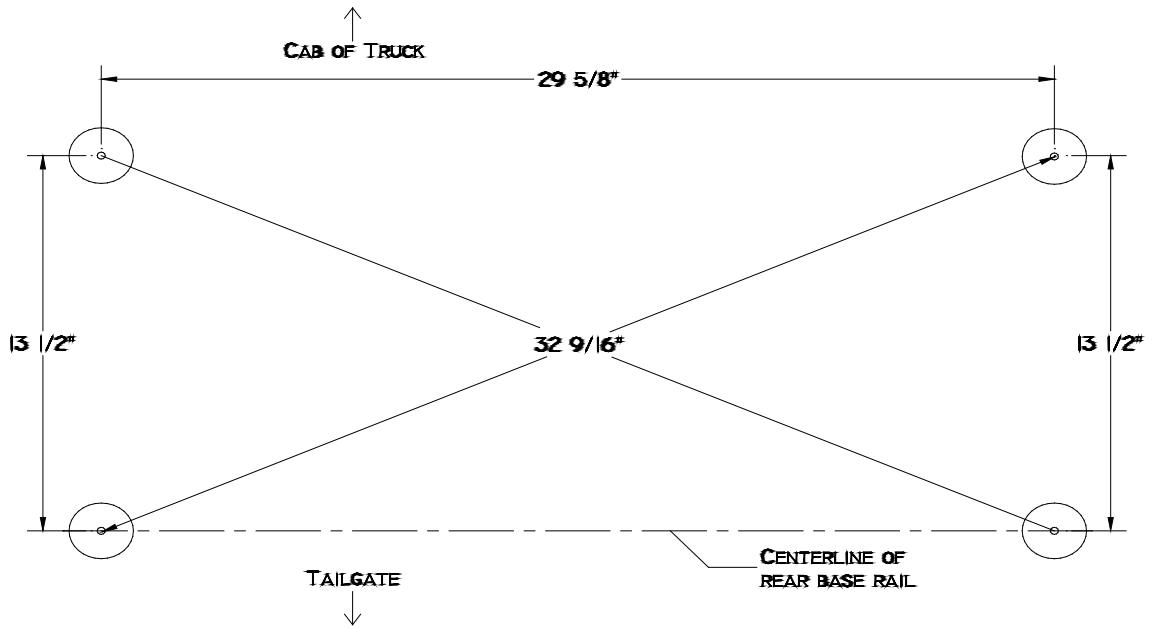

**Drawing #2**

## Front Base Rail

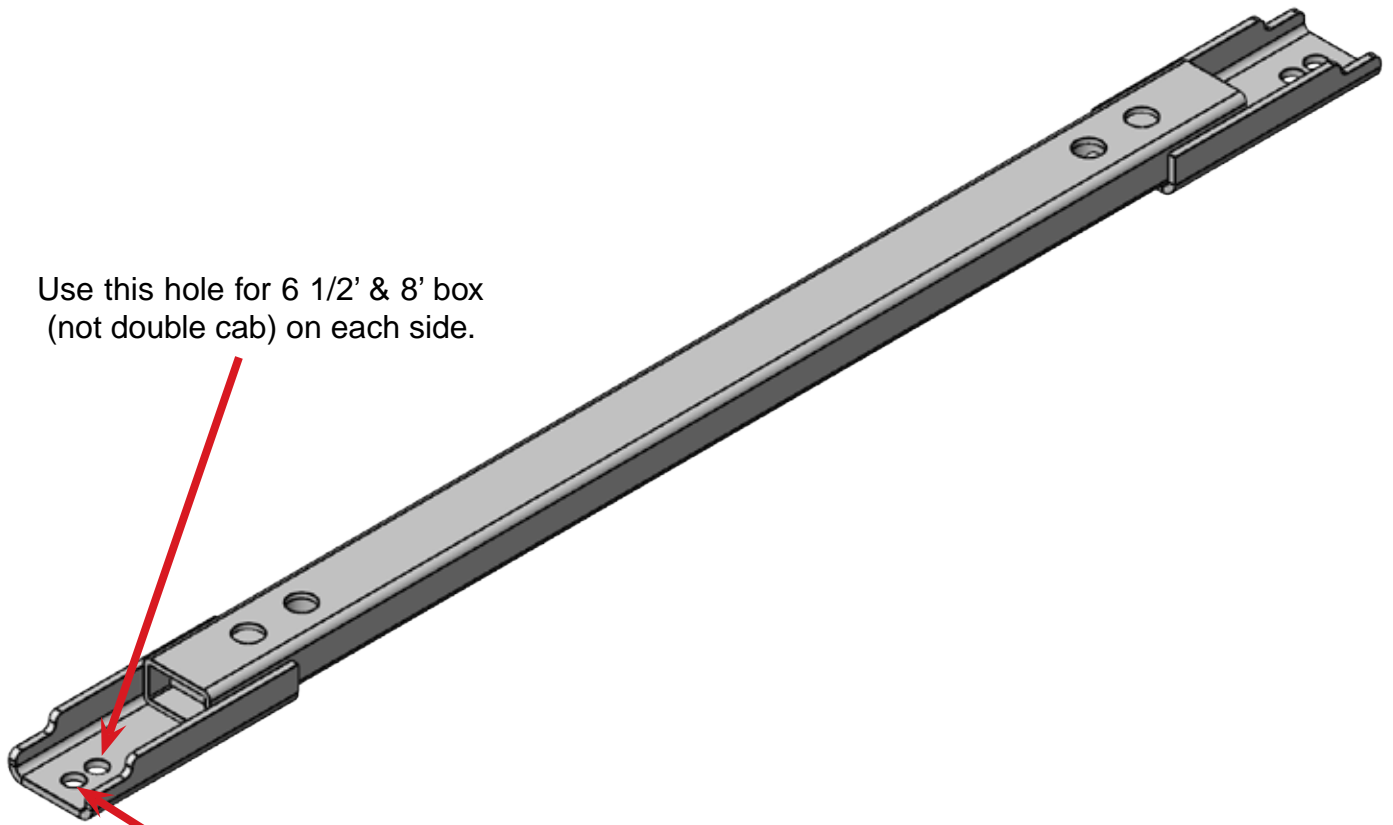

Use this hole for 6 1/2' & 8' box  
(not double cab) on each side.

Use this hole for 5 1/2' & 6 1/2'  
box double cab on each side.

## Base Rail Installation:

**IF the base rails are unable to be slid into position because of insufficient space by the lip of the box bed, then use one of the following two methods to install the base rails.**

1. A) Remove the mounting bolts that attach the box to the truck frame on one side only. Raise and block the box high enough so the base rails can be inserted (with locking pin holes up) and span across and rest on top of each side of the frame (drawing #3). Lower and bolt the box back to the frame. Position base rails under holes drilled in bed.

OR

B) Locate a spot on both sides of the box support cross members on either side of the truck and cut and bend up a 3 1/2" wide section of the sheet metal lip where the bed and the fender well of the box join (drawing #4). Insert base rails (with locking pin holes up) and span across and rest on top of each side of the frame (drawing #3). Bend the sheet metal back down and position rails under holes drilled in bed.

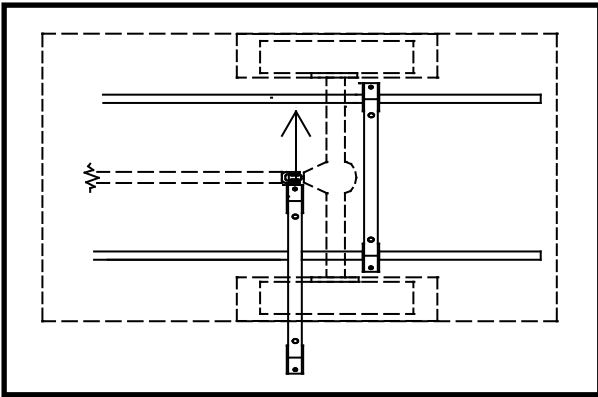

**Drawing #3**

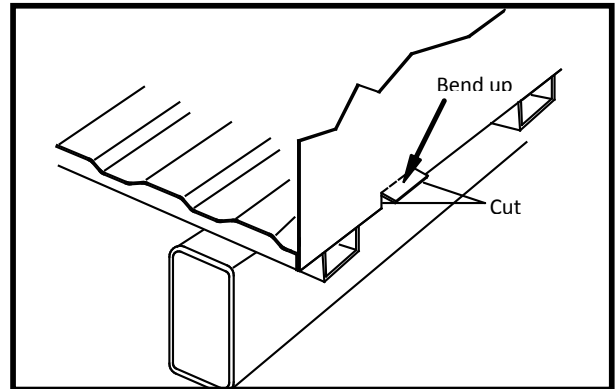

**Drawing #4**

2. With base rails in position below the bed and the base rail holes centered under the holes that were drilled in the bed of the truck, position one of the 3/8" thick shims under each end of the base rails between them and the top of the frame. Drop a 5/8" x 2" bolt (#00290) through the top of the end of the base rail and shim (drawing #5). Re-install and lock the hitch assembly into the base rails from the topside of the box.

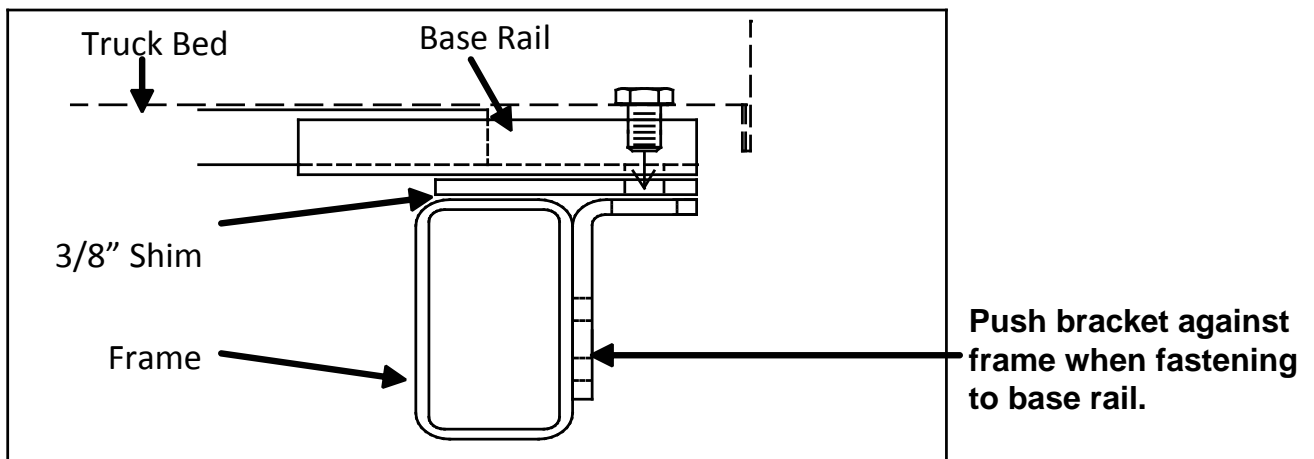

**Drawing #5**

3. Measure and center the entire hitch assembly side to side and front to back so that it is as close to center of the holes in the bed.
4. Attach the frame brackets to the base rails as shown on front cover with the 5/8" bolts that were inserted in the mounting holes and secure with a 5/8" lock washer (#00248) and 5/8" hex nut (#00291).
5. Tighten the bolts to the base rails ensuring that the frame bracket is up against the truck frame.
6. Using the holes in the frame bracket plates as a guide, drill the frame in the two mounting holes on each frame bracket with a 1/2" drill bit. You may want to drill smaller pilot holes to make drilling easier.
7. Brackets will be bolted onto frame by fishing a 1/2" x 1 3/4" knurl bolt (#14266) through frame with a 1/2" fish wire (#14238) and attach with a 1/2" flange nut (#10379) on outside of bracket. There are access holes just behind the rear cross member. These can be used to fish the bolt through.
8. Tighten all bolts.
9. Re-install the rear wheels (if removed), double check all fasteners for tightness, and lower truck (if raised).
10. Unlock and lift the hitch assembly out of the box to make sure it can be removed and inserted with relative ease. If there was any shifting during installation that caused any binding, simply loosen the 4 bolts that attach the base rail to the frame brackets and realign the base rail and retighten.
11. Ensure the side rail locking pins are turned and secured in the locked position with the safety pins. Install the hitch head to the saddle bracket.

### Heat Shield Removal:

On some models there will be a heat shield that is attached to the bottom of the truck box that will have to have a section of it removed to make clearance for the base rail(s).

1. If the shield is below the level of the top of the frame, the base rail will have room to span across from frame rail to frame rail.
2. If the heat shield is above the level of the top of the frame, the shield must be cut and removed before the base rails can be installed.
3. Cut the heat shield just rear of the box support cross member that is at the front of the wheel well of the truck (drawing #2). Remove the screws that hold the rear section of the heat shield in place. A #25 torx head driver or and/or a 10mm wrench or socket will be required to remove these screws.
4. Remove the heat shield.

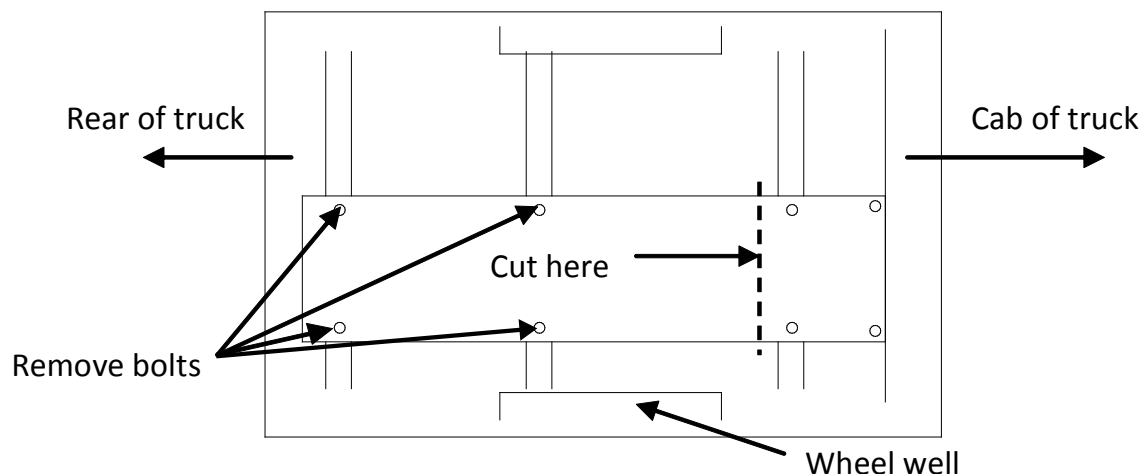

**Drawing #2**