



Ford

BOLT TORQUE SPECIFICATIONS

STANDARD BOLTS			METRIC BOLTS		
Size	Grade	Torque	Size	Grade	Torque
5/16"	5	18 ft/lbs.	8mm	8.8	23 ft/lbs.
3/8"	5	30 ft/lbs.	10mm	8.8	45 ft/lbs.
7/16"	5	50 ft/lbs.	12mm	8.8	78 ft/lbs.
1/2"	5	75 ft/lbs.	14mm	8.8	125 ft/lbs.
5/8"	5	150 ft/lbs.			
3/4"	5	290 ft/lbs.			

FRAME BRACKET

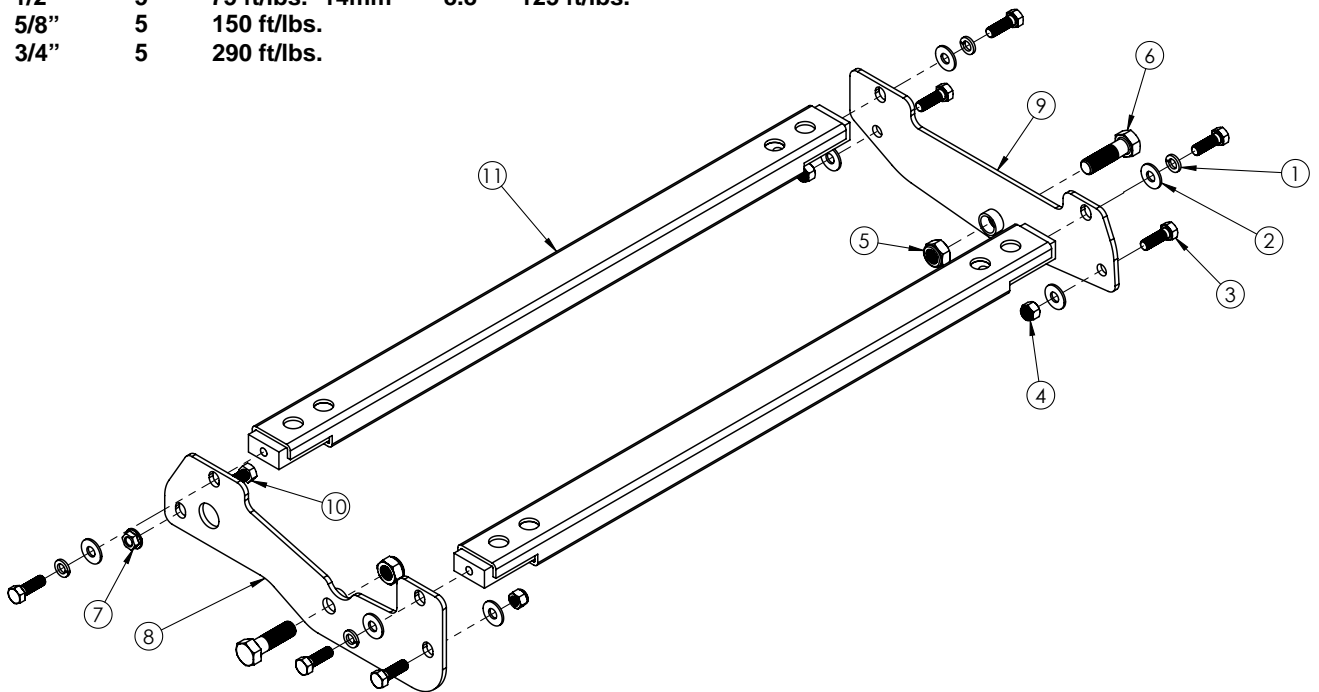

8551000 PARTS LIST

REF. NO.	PART NO.	QTY.	DESCRIPTION
1.	00084	4	1/2" Lock Washer
2.	00085	7	1/2" Flat Washer
3.	01254	7	1/2" x 1 1/2" Hex Bolt Gr.5
4.	02178	3	1/2" -NC Lock Nut
5.	02961	2	3/4" -NC Lock Nut
6.	05047	2	3/4" x 2 1/2" Hex Bolt Gr.5
7.	10379	1	1/2" -NC Flange Nut
8.	14256-76	1	Frame Bracket Driver Side
9.	14257-76	1	Frame Bracket Passenger Side
10.	14266	1	1/2" x 1 3/4" Hex Bolt Knurled Gr.5
11.	14268-76	2	Base Rail
12.	14238	1	1/2" Fish Wire
13.	14335	4	Cap Plug (not shown)

Please order replacement parts by PART NO. and DESCRIPTION.

ASSEMBLY
OPERATION
REPLACEMENT PARTS

READ complete manual CAREFULLY
BEFORE attempting operation.

Doing Our Best to Provide You the Best

OPERATORS MANUAL

FORD: 1999-2013 F250/F350 Super Duty (6 1/2' & 8' Box)
2008-2012 F450 Super Duty (6 1/2' & 8' Box)

8551000 General Assembly and Install Instructions

Hitch Assembly:

1. Place the base rails on a flat level surface, insert and lock the side rail plates into the base rail holes as shown in the supplied hitch instructions.
2. Loosely bolt the saddle bracket and the two cross brackets to the side rails using the fasteners provided with the hitch.
3. Tighten all bolts according to the chart on front page.
4. Unlock and remove the hitch assembly from the base rails and put to the side for later.

Truck Bed Drilling Instructions:

NOTE: On some model years you will have to undo the emergency brake cable from the frame on the driver's side. Reattach after hitch installation. It may also make the install easier if the truck's rear end was lifted and blocked and/or remove the rear wheels to have more access for drilling of the frame.

The four 2" holes that need to be drilled through the box are done by the following method:

1. Use the measurements shown on the following page (drawing #1) to mark out the four holes that will be drilled through the truck bed.
2. Start out by measuring 37 3/4" from the end of the bottom of the truck bed (tailgate end) to a point on the left side of center of the bed and mark it. Do the same on the right side of center of the bed and mark it. Draw a line across the bed using these two marks as a reference.
3. Measure out and find the center of the truck bed and draw a line from the front to the rear of the bed.
4. Measure out 14 13/16" to either side of the middle center line slightly ahead of the fender well and slightly behind the fender well.
5. Draw a line between these two points. Do the same on the other side.
6. Measure out (towards the cab) 13 1/2" from the points where the line that goes across the bed intersects with the two lines that are 14 13/16" off the center running the length of the bed. Mark these two points.
7. There should now be four spots marked out for drilling. Double check that the rear to hole marks are exactly 37 3/4" from the end of the bed and that the front holes marks are exactly 13 1/2" forward of those marks.
8. Check the hole marks from side to side and make sure they are exactly 29 5/8" apart from each other.
9. Finally, check for square by measuring diagonally from opposite corners (see drawing #2 on next page). The measurement should be the same both ways. It should measure 32 9/16".
10. After all the hole marks have been double checked for proper placement, use a center punch and hammer to mark out the spots for drilling.
11. Drill the holes using a 2" hole saw. Deburr the holes using a small file and apply some touch up paint to match color (not supplied).

Drawing #1

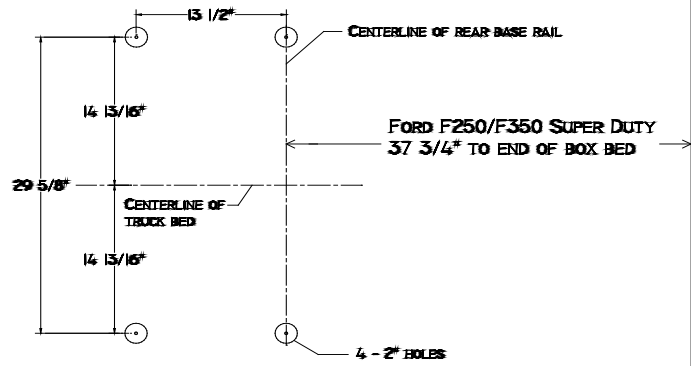

Drawing #2

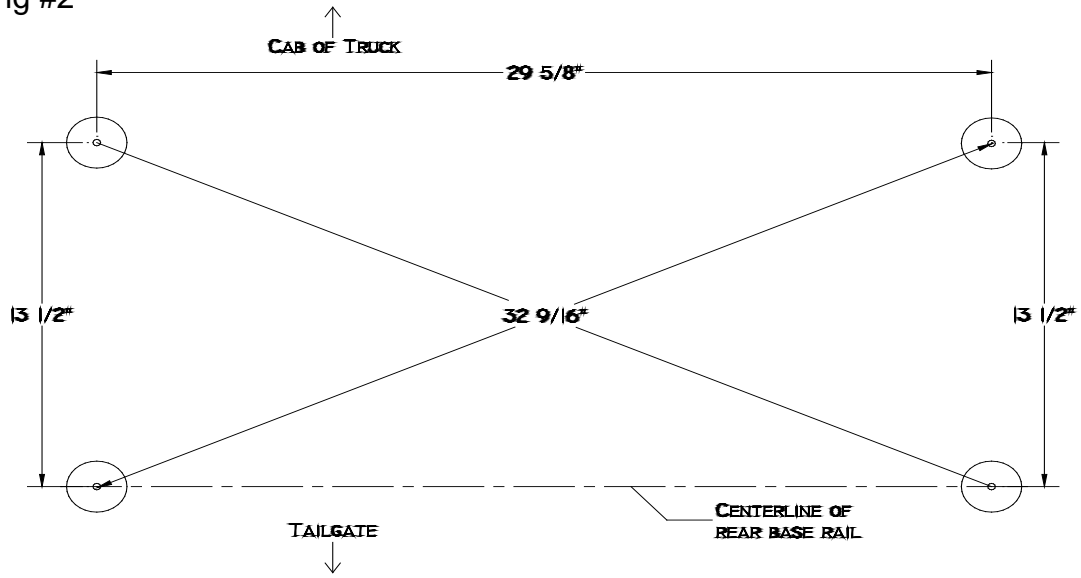

Base Rail Installation:

1. With the four 2" holes drilled in the truck bed, insert the base rails one at a time with hole side up on top of the truck frame at the point just forward of the axle (see drawing #3 below). Insert the first rail all the way to span across to the other side of the frame and slide it back towards the holes closest to the tailgate and position it under the holes. Repeat with the second base rail and position under the forward set of holes.

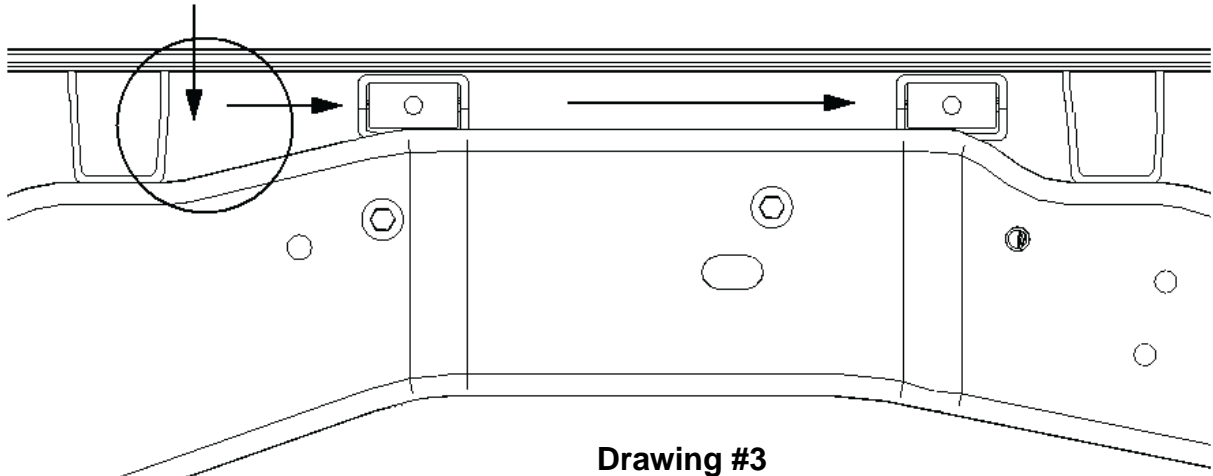

2. With base rails in position below the bed and the base rail holes centered under the holes that were drilled in the bed of the truck, re-install and lock the hitch assembly into the base rails from the top side of the box.
3. Measure and center the entire hitch assembly side to side and front to back so that it is as close to center of the holes in the bed.
4. Attach the frame brackets (oval holes) to the tapped holes in the ends of the base rails using the 1/2" x 1 1/2" bolts (01254) and lock washers (00084) provided.
5. Tighten the bolts to the base rails.
6. For the 2011 model year installation is a no drill application that uses existing frame holes. See driver side drawing below and passenger side drawing on next page.

Driver Side Bolt Pattern

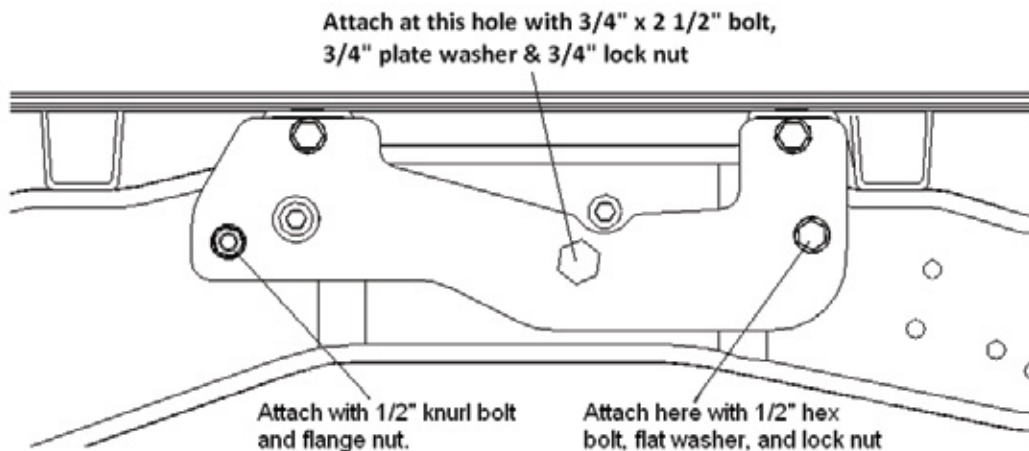

Passenger Side Bolt Pattern

Attach at this hole with 3/4" x 2 1/2" bolt,
3/4" plate washer & 3/4" lock nut

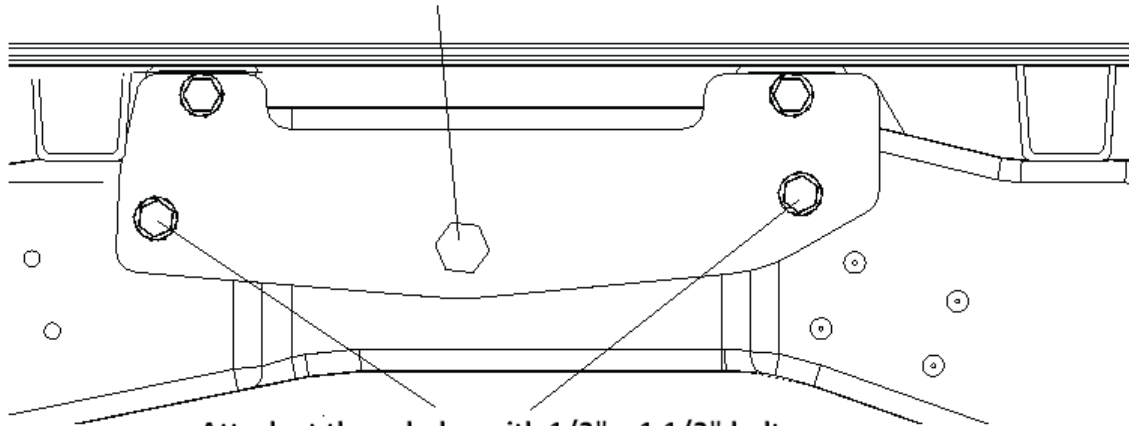

Attach at these holes with 1/2" x 1 1/2" bolts,
1/2" flat washers & 1/2" lock nuts

7. For 2010 and earlier models, use the holes in the frame bracket plates as a guide and drill the frame in the two smaller mounting holes on each frame bracket with 33/64" drill bit. You may want to drill smaller pilot holes to make drilling easier. The larger 3/4" hole and bolt is not used for these earlier installs.
8. It is best to install a 1/2" x 1 1/2" bolt, washer and lock nut (02178) after each hole is drilled to ensure there is no shifting of the hitch while drilling the next hole(s).
9. Tighten all bolts.
10. Re-install the rear wheels (if removed), double check all fasteners for tightness and lower truck (if raised).
11. Unlock and lift the hitch assembly out of the box to make sure it can be removed and inserted with relative ease. If there was any shifting during installation that caused any binding, simply loosen the four bolts that attach the base rail to the frame brackets and re-align the base rail and re-tighten.
12. Ensure the side rail locking pins are turned and secured in the locked position with the safety pins. Install the hitch head to the saddle bracket.