



Doing Our Best to Provide You the Best

HJ26180, Rev 3
02/18

5TH WHEEL HITCH

Recon

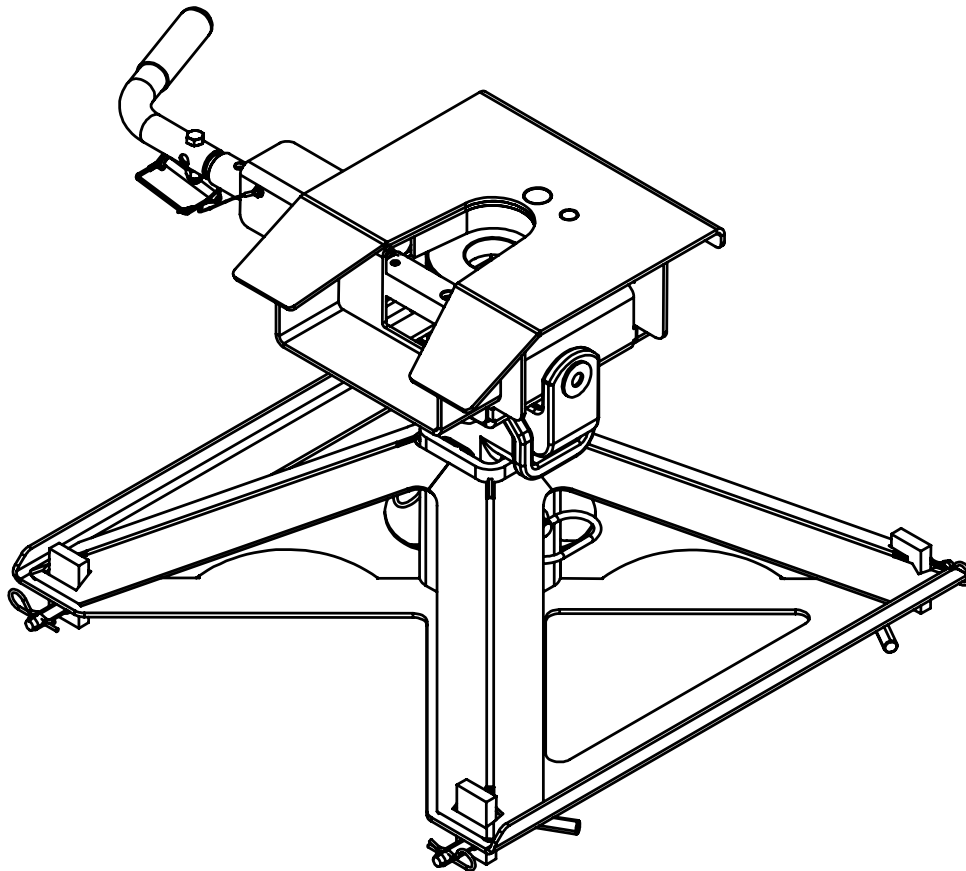

OPERATOR MANUAL

Introduction

Thank you for purchasing a Demco Recon hitch. We feel you have made a wise choice and hope you are completely satisfied with your new piece of equipment.

Please consult vehicle owner's manual for 5th wheel towing instructions.

GENERAL INFORMATION

1. Unless otherwise specified, high-strength (grade 5) (3 radial-line head markings) hex head bolts are used throughout assembly of this piece of equipment.
2. Whenever the terms “LEFT” and “RIGHT” are used in this manual it means from a position behind the vehicle and facing forward.
3. When placing a parts order, refer to this manual for proper part numbers and place order by **PART NO. and DESCRIPTION.**

Bolt Torque for Standard bolts *

“A”	GRADE 2		GRADE 5		GRADE 8	
	lb-ft	(N.m)	lb-ft	(N.m)	lb-ft	(N.m)
1/4”	6	(8)	9	(12)	12	(16)
5/16”	10	(13)	18	(25)	25	(35)
3/8”	20	(27)	30	(40)	45	(60)
7/16”	30	(40)	50	(70)	80	(110)
1/2”	45	(60)	75	(100)	115	(155)
9/16”	70	(95)	115	(155)	165	(220)
5/8”	95	(130)	150	(200)	225	(300)
3/4”	165	(225)	290	(390)	400	(540)
7/8”	170	(230)	420	(570)	650	(880)
1”	225	(300)	630	(850)	970	(1310)

Bolt Torque for Metric bolts *

“A”	CLASS 8.8		CLASS 9.8		CLASS 10.9	
	lb-ft	(N.m)	lb-ft	(N.m)	lb-ft	(N.m)
6	9	(13)	10	(14)	13	(17)
7	15	(21)	18	(24)	21	(29)
8	23	(31)	25	(34)	31	(42)
10	45	(61)	50	(68)	61	(83)
12	78	(106)	88	(118)	106	(144)
14	125	(169)	140	(189)	170	(230)
16	194	(263)	216	(293)	263	(357)
18	268	(363)	--	--	364	(493)
20	378	(513)	--	--	515	(689)
22	516	(699)	--	--	702	(952)
24	654	(886)	--	--	890	(1206)

WARNING

Failure to follow these instructions may result in death or serious injury!

- Trailer and its contents together must not exceed truck, hitch and/or trailer tow ratings.
- Towing vehicle must have a manufacturer's rated towing capacity equal to or greater than the gross trailer weight (dry weight of the trailer plus payload of the trailer).
- Gross weight of trailer must not exceed weight rating of hitch assembly.
- King pin weight must not exceed 4,000 pounds. If in doubt have king pin weight measured by qualified facility

1. Demco 5th wheel hitches are designed for use with recreational fifth wheel trailers only.
2. Use only a SAE 2-inch king pin with your Demco 5th wheel Fifth Wheel Hitch.
3. Approximately 15%-25% of trailer weight should be on hitch (Pin Weight).
4. Trucks come in many different configurations. Demco hitches are designed for use in light trucks such as the Ford F-Series, the Chevy Silverado and the Dodge Ram. Demco recommends the use of long bed (8ft) light trucks for the best combination in truck - trailer turning clearance.

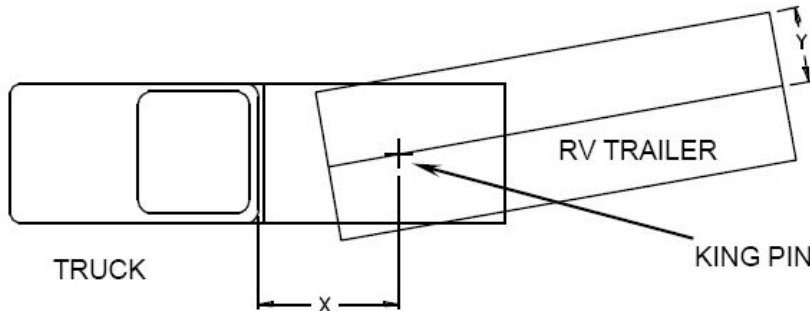

Rule of thumb: The distance from the back of the truck cab to the center of the rear truck axle ("X"), should be approximately 4 inches greater than one-half the trailer width ("Y")

5. If a short bed pickup (less than 8 ft. but longer than 6 ft.) is to be used for towing, Demco recommends the trailer be equipped with an extended pin box to help gain additional truck - trailer turning clearance (See trailer manufacturer for options). It also may be helpful to add a Demco 5th wheel Ultra Slide for increased turning clearance for low speed, non- highway maneuvering.
6. The height of the hitch and the pin box should be adjusted so the trailer is approximately level as it is towed. Allow approximately 6 inches clearance between the top of the pickup walls and the underside of the front of the trailer for pitch and roll of the trailer. Allow more clearance between pickup walls and trailer for off road use.

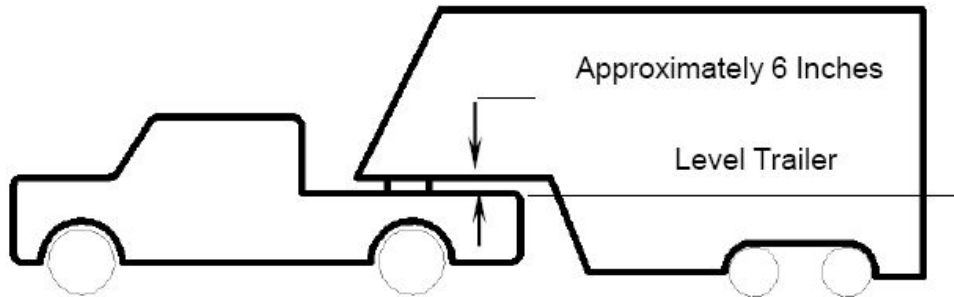

5th Wheel Double Pivot Head Assembly

The dampener stops the hitch head from flopping back and forth in the truck when the trailer is not hooked up. The urethane compresses under load so it does not restrict the fore and aft movement when coupled.

Before attaching the hitch head to the saddle assembly the urethane dampener will need to be installed. It is included in the bag with the bolt and nut for the hitch handle. Simply press into hole that is punched into the bottom side of the hitch as shown in **Figure A**.

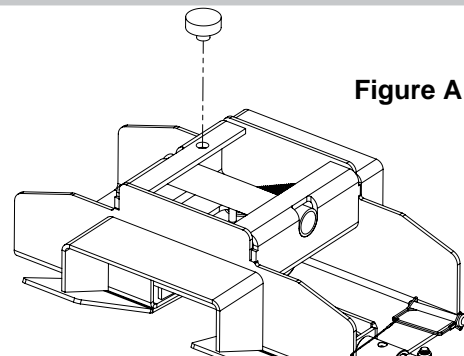
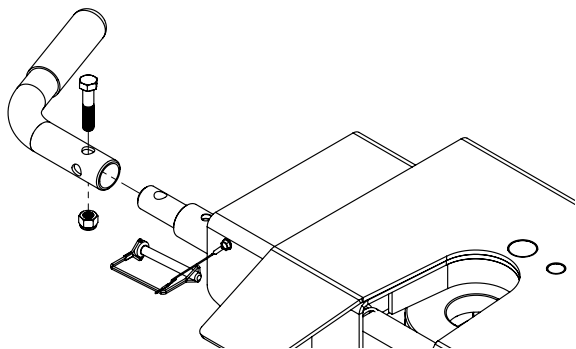

Figure A



Note (Read carefully before installing): Handle can be positioned toward the front or the back if it is found to interfere with the trailer in any way. Verify this before traveling.

1. Slide yellow gripped handle over locking bar, the handle may point forward, upward or backward. ****DO NOT** have pointing upward if it is found to interfere with the trailer in any way during turning.
2. Fasten with 3/8" x 1 3/4" bolt and lock nut provided.

WARNING

DO NOT install hitch handle in a position that the pin box could come in contact with or interfere with the latch of the hitch handle when turning! If the pin box contacts the hitch handle or its latch when turning, the trailer may become unhitched.

Procedures to Close Locking Bar

Pull on handle with slight pressure while moving the secondary jaw to the right until the primary jaw is released. Slowly allow the handle to retract into the 5th wheel head. Caution: Do not put hands/fingers into the lock jaw area.

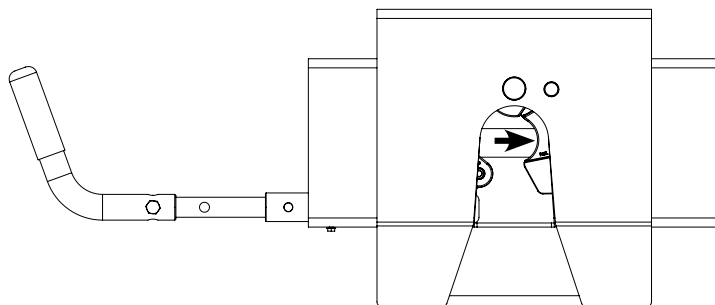

5th wheel Pivot Head Maintenance

Each of our 5th wheel fifth wheel hitches has been tested and pre-greased at our production facility to help ensure easy operation of your new product.

As it is a new piece of equipment with some moving parts, a period of wearing in may be necessary to facilitate smoother operation for your new fifth wheel hitch. The most important thing to remember is to keep all moving parts well greased and lubricated. Your doing this will help to ensure longer product life.

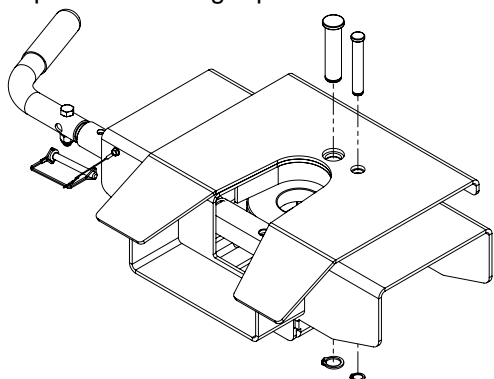

Squirt WD40 or other oil into locking bar tube, open and close locking bar several times and wipe bar clean.

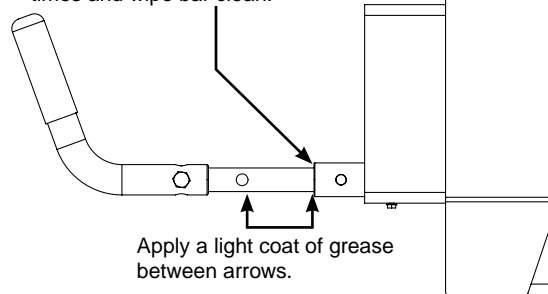

Apply a light coat of grease between arrows.

Jaw pins can be removed and greased by removing or unhooking jaw spring and both snap rings. Tap the pin up from bottom. Clean pins and inspect for wear, apply light coat of grease and reinstall pins, snap rings and spring.

Coupling Procedure

1. Place wheel chock on each side of trailer wheels.
2. Adjust trailer jacks until trailer is a height for hook up. King pin plate should contact hitch approximately 1/2" below level.

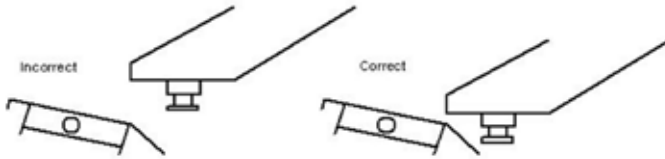

3. Lower tailgate of truck.
4. If hitch is in locked position, remove safety pin and pull handle out to the "Ready to Couple" position.
5. Line truck so that the hitch will accept king pin. Back truck up slowly towards trailer until king pin engages. Hitch will lock when king pin is fully engaged.
6. With the trailer coupled, visually check to see if hitch is completely locked by looking at the handle position, as well as visually checking to ensure that the jaw bar has traveled completely across the front of the king pin.
7. Place safety pin thru the tab and the hole in the handle. This will prevent handle from opening.
8. Connect power cable and breakaway switch cable between truck and trailer.
9. Close and latch tailgate.
10. Apply trailer brakes and try to pull forward slowly to double check that hitch is locked. Trailer should prevent truck from moving.
11. Completely raise trailer jacks. Check for proper clearance between truck box and trailer.
12. Pick up and store wheel chocks. You are now ready to travel.

Uncoupling Procedure

1. Place wheel chocks on both sides of trailer wheels.
2. Lower trailer jacks to ground and extend until load is level with truck suspension. If on soft ground, place support under jack feet to prevent trailer from settling.
3. Lower tailgate on truck.
4. Disconnect power cable and break away switch.
5. Remove lock pin and pull handle out. If handle will not stay out, install safety pin in second handle hole just outside of frame handle bushing.
6. Drive truck slowly away from trailer.

Very Important Maintenance Instructions

1. Inspect all fasteners for tightness at least every 2,000 miles of operation.
2. Inspect jaw and jaw bar for freedom of movement and proper operation before each use. Replace all damaged or worn parts.
3. Keep all moving parts of hitch well lubricated.
4. It is recommended to use grease or a 3/16" maximum Teflon disc to help prevent wear on top plate surface.

Very Important Warnings

1. Know your vehicle and trailer GVWR and CVWR. DO NOT exceed capacity of hitch.
2. Hitch is for use with only a standard 2" king pin.

Safety pin MUST be fastened securely before moving vehicle and/or traveling

Ready to Couple

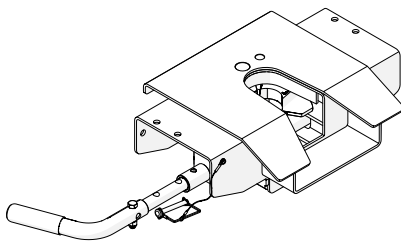

Remove safety lock pin if installed and pull handle until jaw locks open.

Coupled and Locked

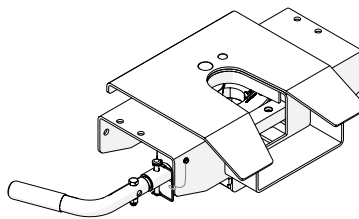

With handle in "Ready to Couple" position, back-up tow vehicle to couple trailer and hitch. Insert safety pin thru tab and hole in handle. NOTE: Ensure safety lock pin is inserted properly. Apply trailer brakes before jacks are raised and wheel chocks are removed.

Uncoupled

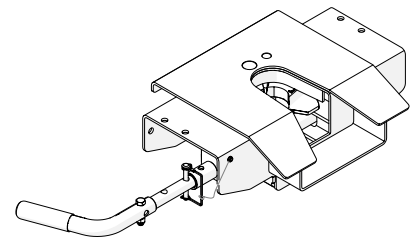

To uncouple, remove safety pin, pull handle straight out until the jaw locks open. If jaw will not stay open, install safety pin in second handle hole just outside of frame handle bushing.

VISUALLY INSPECT JAW LOCKING MECHANISM BEFORE TRAVELING

Recon Installation Instructions

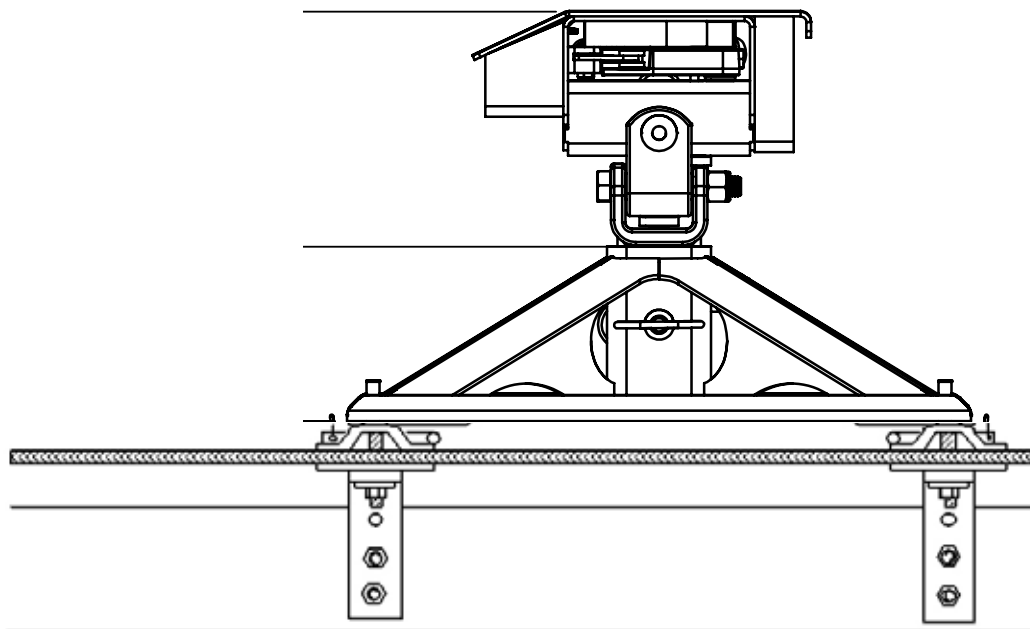

Install bedrail pull pins from under the side rail so that the hitch pin secures in the open.

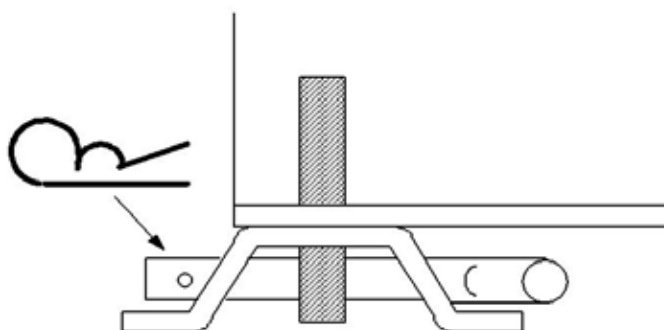

1. The correct height for the hitch is such that there is approximately 6" of clearance between the top of the truck box and the bottom of the trailer overhang. The Demco Recon hitch has 2-1/2" of adjustment up or down in 1-1/4" increments.
2. Once the proper height has been determined, slide the center post to the right position and pin with cross pin and tighten setscrew and jam nut of base. It is best to use a 3/4" twelve point socket to tighten the set screw to 100 ft/lbs and a 15/16" deep well socket for the jam nut.
3. Place hitch on bed rails and pin the hitch in place with supplied red rail pins and hair pins.

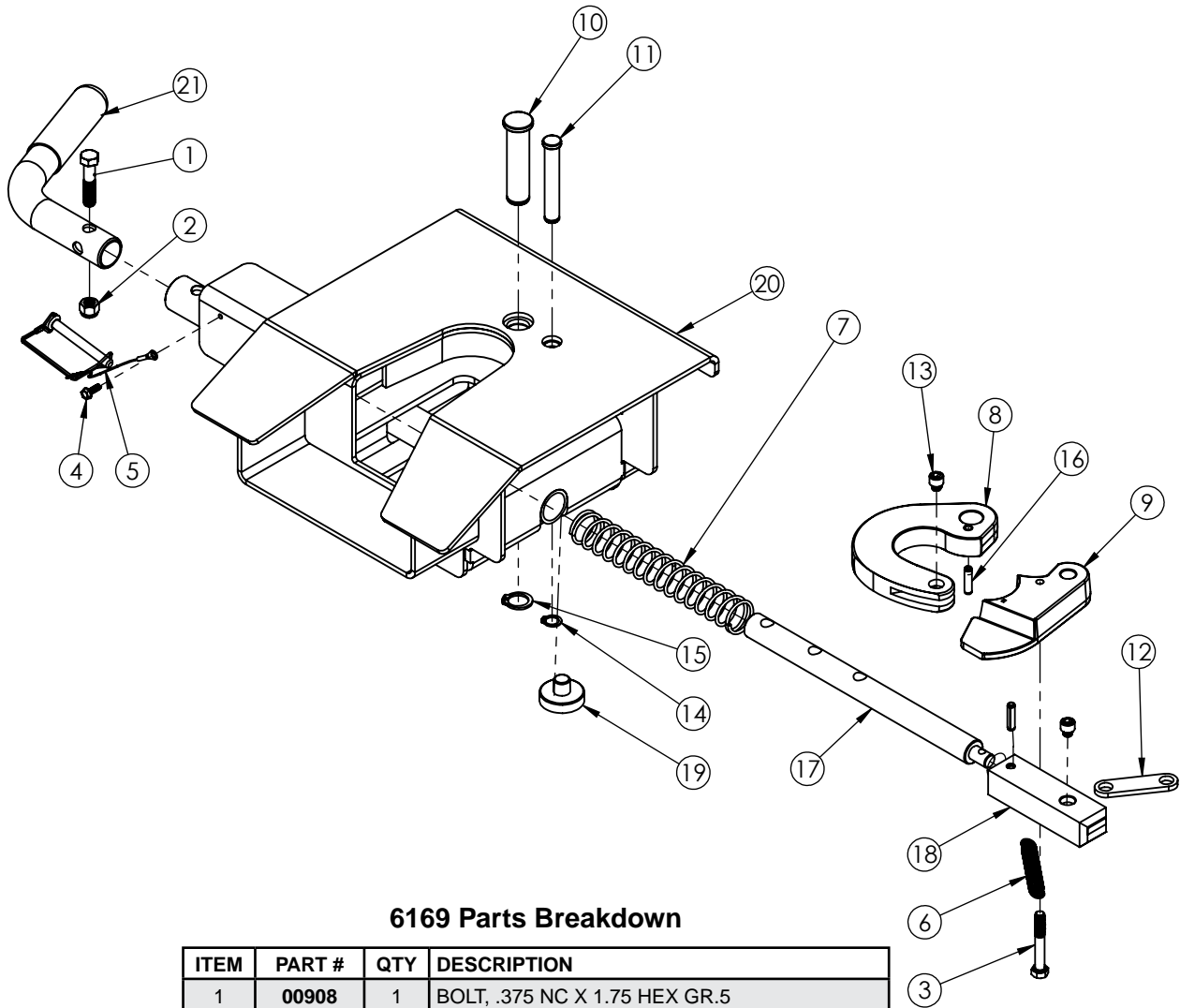

6169 Parts Breakdown

ITEM	PART #	QTY	DESCRIPTION
1	00908	1	BOLT, .375 NC X 1.75 HEX GR.5
2	02592	1	NUT, .375NC NYLON LOCK
3	03547	1	BOLT .313NC X 2.25 GR5 HEX
4	03787	1	SCREW #10NC X .50 SELF DRILLING HEX HD
5	05337	1	SAFETY LOCK PIN ASSEMBLY
6	14315	1	SPRING, TENSION, .063 WIRE X .50 OD X 2.75
7	14385	1	SPRING COMPRESS .105 MW
8	14594-95	1	JAW HOOK
9	14595-95	1	SECONDARY LATCH JAW
10	14735-95	1	MAIN JAW PIN
11	14736-95	1	SECONDARY JAW PIN
12	14737-95	1	BAR/JAW LINK
13	14747	2	SCREW .313NC X .25 SOCKET HD CAP
14	14749	1	SNAP RING EXT FOR .50 SHAFT
15	14750	1	SNAP RING EXT F/ .75SHAFT
16	14865	2	ROLL PIN, .25 X 1.00
17	14867-95	1	LEVER ARM BAR
18	14869-95	1	LOCK BAR
19	15769	1	URETHANE PIVOT BUMPER 3/8" THICK
20	15801-76	1	5th WHEEL DOUBLE PIVOT HEAD
21	15934	1	HANDLE ASSEMBLY

Please order replacement parts by PART NO. and DESCRIPTION

6180 Recon Base Parts Breakdown

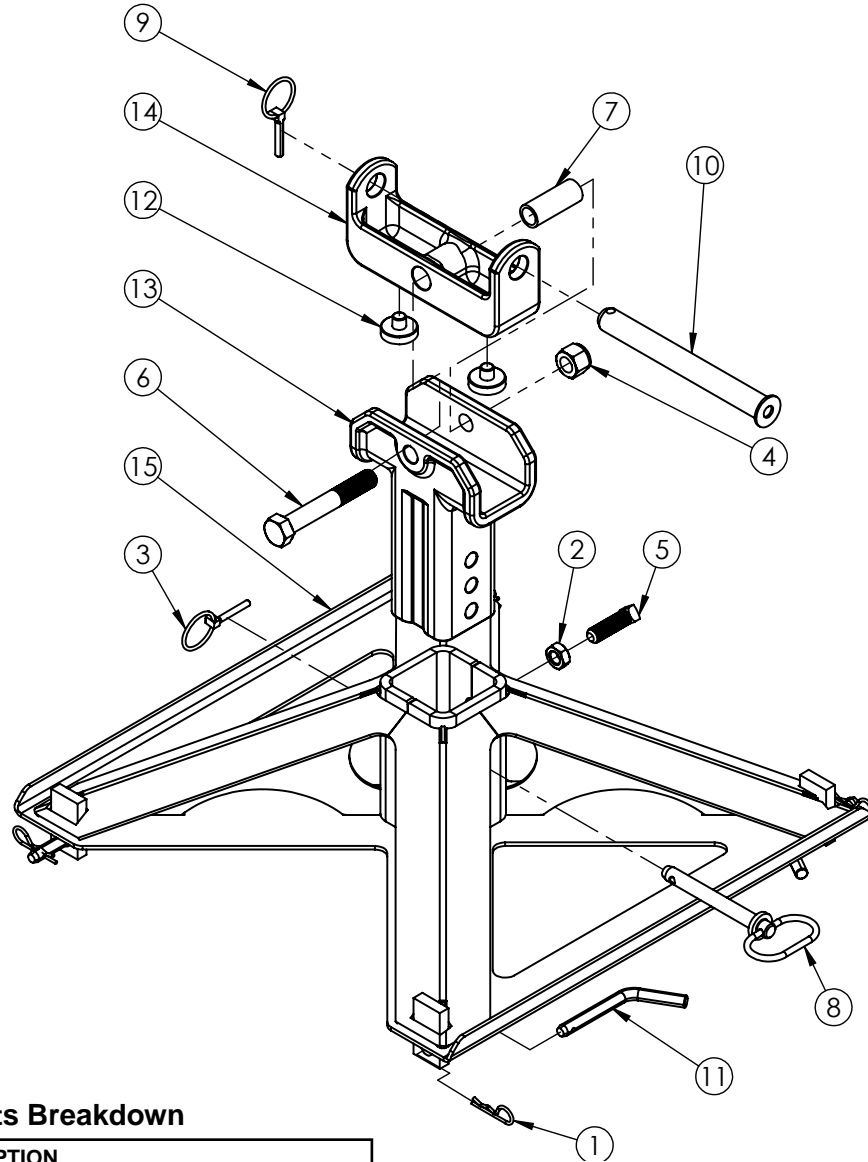

6180 Base Parts Breakdown

ITEM	PART #	QTY	DESCRIPTION
1	00182	4	HAIR PIN, .120 WIRE X 2.375
2	00489	1	NUT .625NC JAM RIGHT HAND
3	02397	1	LYNCH PIN
4	02961	1	.75NC NYLON INSERT LOCK NUT
5	09946	1	SET SCREW .625NC X 2.00 SQ HD
6	11099	1	BOLT, .75 NC X 5.00 HEX HEAD GR. 8
7	11337-95	1	HINGE BUSHING
8	11593	1	ADD DESCRIPTION
9	14221	1	LYNCH PIN, .313
10	14222-95	1	AS PIVOT PIN 1" X 9.38
11	14566-95	4	ATTACHING PIN
12	15769	2	URETHANE PIVOT BUMPER 3/8" THICK
13	15773-76	1	UPRIGHT CASTING
14	15778-76	1	5th WHEEL HEAD YOKE
15	15802-76	1	A-FRAME BASE

Please order replacement parts by PART NO. and DESCRIPTION



Doing Our Best to Provide You the Best

HJ26071, Rev 6
03/18

5TH WHEEL BED RAILS

6071 Premier/UL Bed Rail Industry Standard

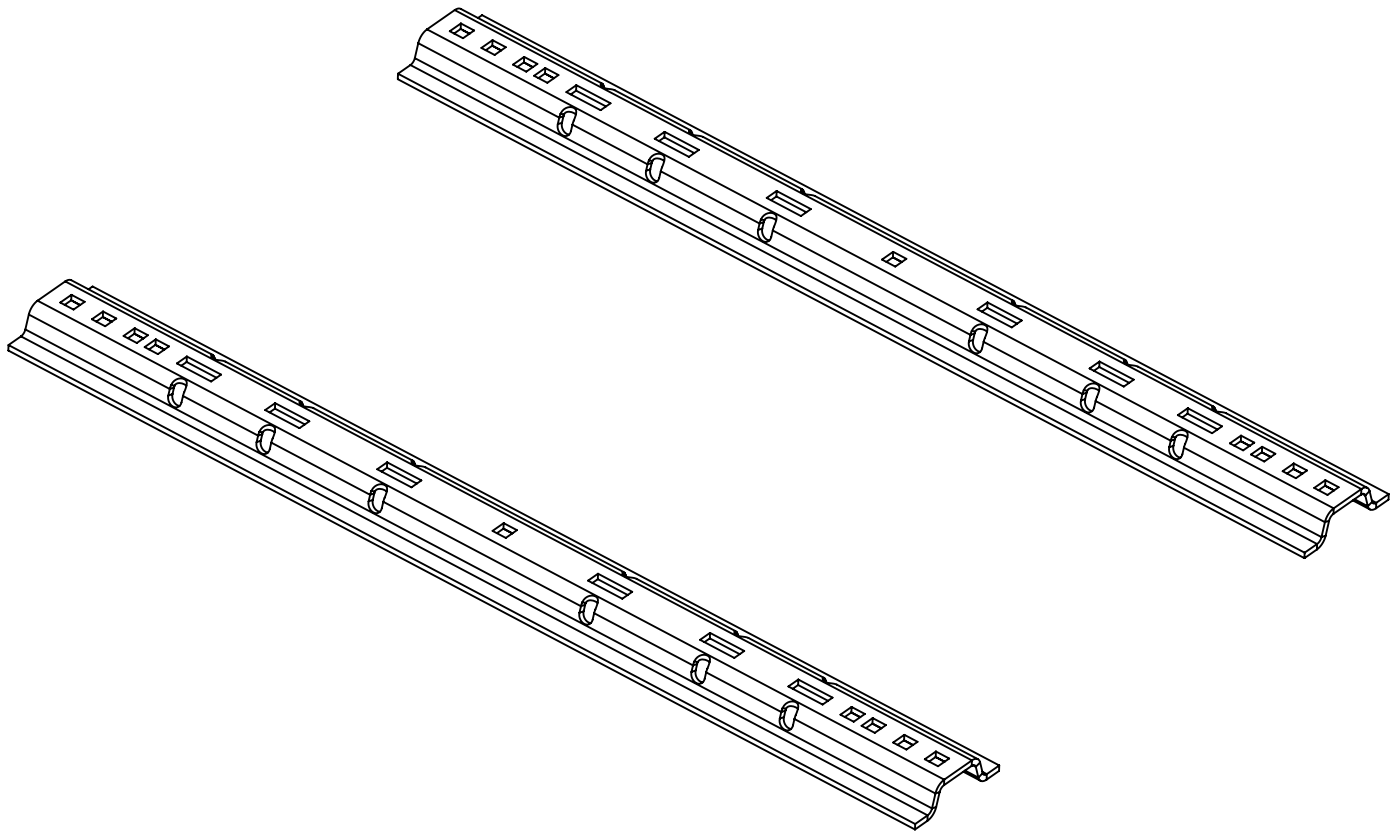

OPERATOR MANUAL



Torque Specifications

BOLT TORQUE DATA FOR STANDARD NUTS, BOLTS, AND CAPSCREWS.

Tighten all bolts to torques specified in chart unless otherwise noted. Check tightness of bolts periodically, using bolt chart as guide. Replace hardware with same grade bolt.

NOTE: Unless otherwise specified, high-strength Grade 5 hex bolts are used throughout assembly of equipment.

Torque figures indicated are valid for non-greased or non-oiled threads and heads unless otherwise specified. Therefore, do not grease or oil bolts or capscrews unless otherwise specified in this manual. When using locking elements, increase torque values by 5%.

* GRADE or CLASS value for bolts and capscrews are identified by their head markings.

Bolt Torque for Standard bolts *

"A"	GRADE 2		GRADE 5		GRADE 8	
	lb-ft	(N.m)	lb-ft	(N.m)	lb-ft	(N.m)
1/4"	6	(8)	9	(12)	12	(16)
5/16"	10	(13)	18	(25)	25	(35)
3/8"	20	(27)	30	(40)	45	(60)
7/16"	30	(40)	50	(70)	80	(110)
1/2"	45	(60)	75	(100)	115	(155)
9/16"	70	(95)	115	(155)	165	(220)
5/8"	95	(130)	150	(200)	225	(300)
3/4"	165	(225)	290	(390)	400	(540)
7/8"	170	(230)	420	(570)	650	(880)
1"	225	(300)	630	(850)	970	(1310)

Bolt Torque for Metric bolts *

"A"	CLASS 8.8		CLASS 9.8		CLASS 10.9	
	lb-ft	(N.m)	lb-ft	(N.m)	lb-ft	(N.m)
6	9	(13)	10	(14)	13	(17)
7	15	(21)	18	(24)	21	(29)
8	23	(31)	25	(34)	31	(42)
10	45	(61)	50	(68)	61	(83)
12	78	(106)	88	(118)	106	(144)
14	125	(169)	140	(189)	170	(230)
16	194	(263)	216	(293)	263	(357)
18	268	(363)	--	--	364	(493)
20	378	(513)	--	--	515	(689)
22	516	(699)	--	--	702	(952)
24	654	(886)	--	--	890	(1206)

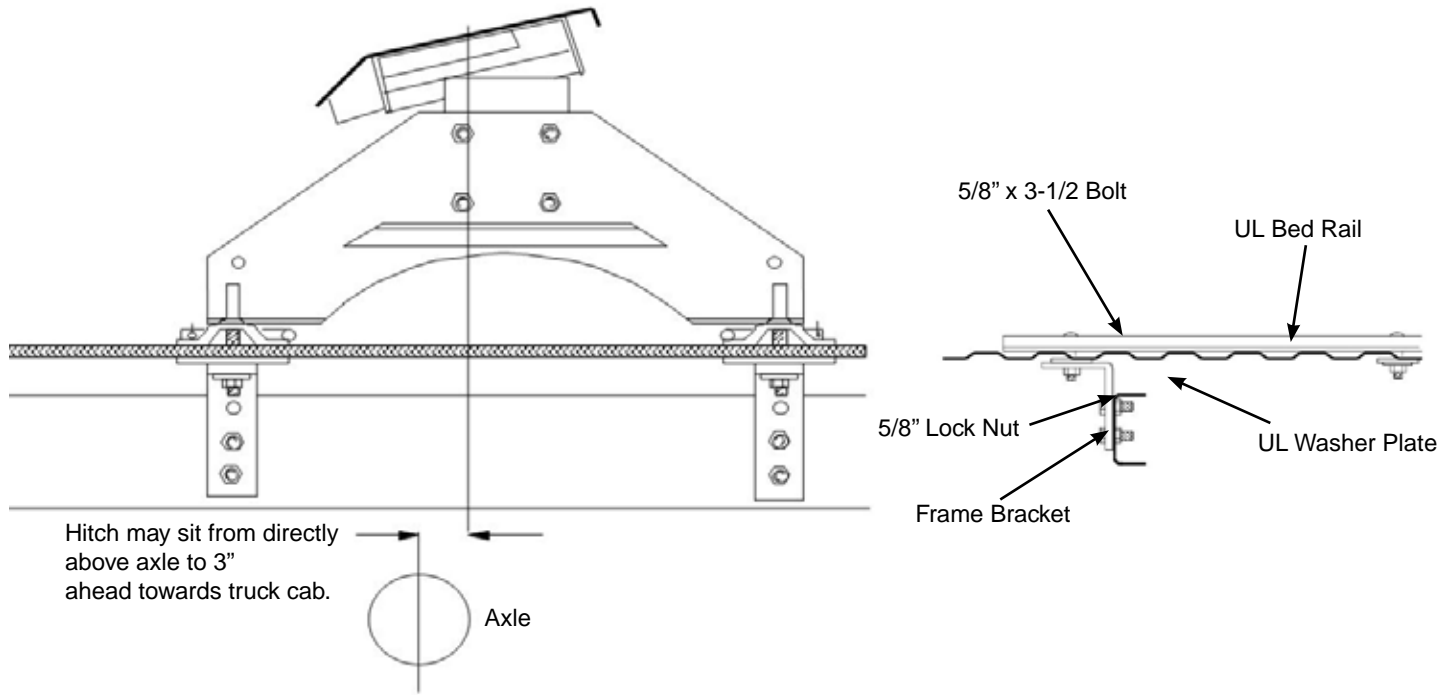

IMPORTANT NOTICE: This installation may require different frame brackets for the various truck models. This kit does not contain any frame brackets for this reason.

The Hijacker hitch must be completely assembled and adjusted to the proper height before securing into the box of the truck. Never tow with the hitch in the maneuvering or parking position (sliding models only).

1. The correct height for the hitch is such that there is approximately 6" of clearance between the top of the truck box and the bottom of the trailer overhang. All Hijacker hitches have 4" of adjustment up or down in 1" increments.
2. Once the proper height has been determined, bolt the hitch saddle and side rail assemblies together and pin them into the bed rails.
3. The ideal location for the center of the hitch is directly over the axle to up to 3" ahead of it, and it must be centered side to side in the box of the truck. As noted above, specific install instructions for the different vehicles are available.
4. When hitch and rail assembly are in the proper position, make sure that the bed rails are parallel to each other. Drill four 5/8" holes, 2 per bed rail, through the bed of the truck using the square holes as guides. There are 4 square holes on the ends of the bed rails to choose from. The most commonly used hole is the outer hole, but some installations may require using the middle holes or the inner most hole. Check the distance of the truck frame at the point where the bed rails sit above it to determine the best holes to use or use which ever holes the specific install instruction states to use (see Important Notice above). Drop in a 5/8" x 3 1/2" hex bolt or 5/8" x 3 1/2" carriage bolt through the holes as they are drilled to prevent any movement during installation.
5. Securely fasten the frame brackets underneath (see other side of page) by pushing them up against the frame and tightening up the nut. Next drill two holes thru the frame and use the 1/2" x 1 1/2" bolts, nuts, and flat washers to secure the brackets to the frame. **IT IS IMPORTANT TO USE 4 L SHAPED FRAME BRACKETS OR VEHICLE SPECIFIC FRAME BRACKETS.**

Ultra Hitch Install Shims

Due to some of the configurations of corrugations in the bed of the box, we supply for use 4 - 3/8" x 1 1/2" x 5" spacers to prevent the box from collapsing in slightly during tightening of the bolts that go down through the box. With the space between the ribs wider and taller on some trucks, the end of the base rails do not span across the valley of the ribs creating a potential for crushing. The following procedures are recommended.

**The use of the UL FB washers is not needed when using the 3/8" spacers for these installations.

Extra 3/8" x 1 1/2" x 5" shims are available from Demco so they can be stocked by the dealer/installers along with any optional frame brackets.

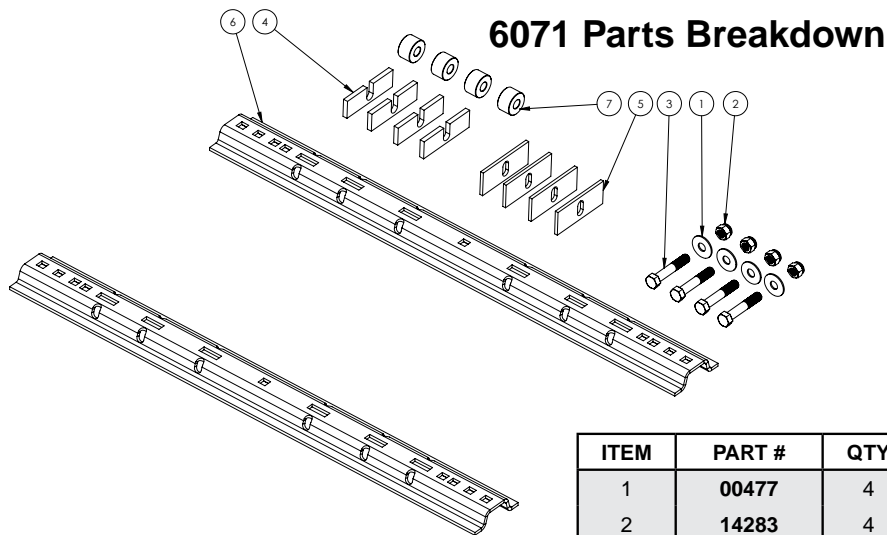
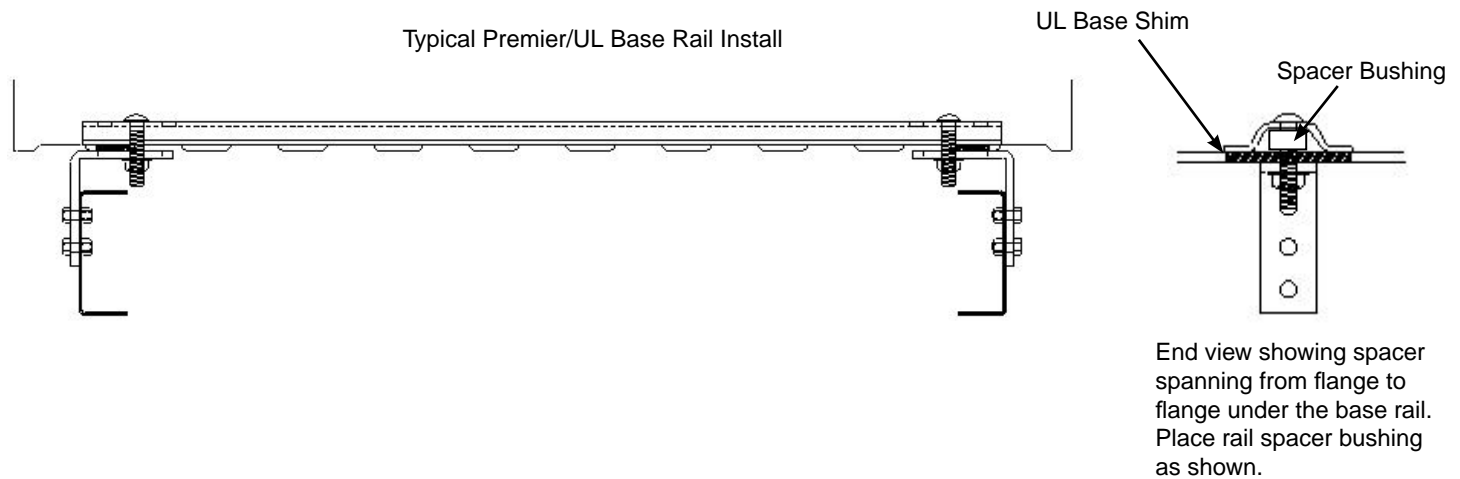

ITEM	PART #	QTY	DESCRIPTION
1	00477	4	WASHER, FLAT, .625
2	14283	4	NUT, .625NC SERRATED FLANGE HEX
3	05103	4	.625NC X 3.50 HEX BOLT
-	14321	4	.625NC x 3.50 CARRIAGE BOLT (NOT SHOWN)
4	14156-95	4	UL BASE SHIM
5	14157-95	4	UL FB WASHER
6	14620-76	2	UL STANDARD PREMIER BASE RAIL
7	15182	4	RAIL SPACER BUSHINGS

Please order replacement parts by PART NO. and DESCRIPTION

