

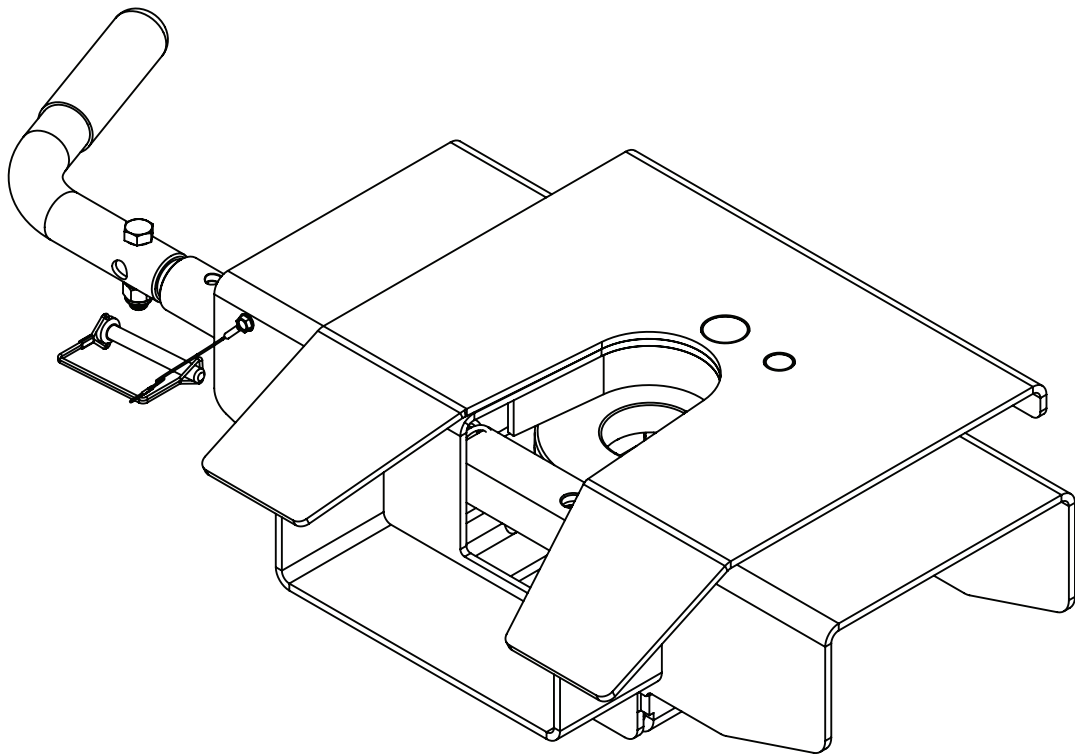

# Demco

## 5th Wheel Hitch

### 6076 DOUBLE PIVOT HEAD



**READ** *complete manual CAREFULLY  
BEFORE attempting operation.*

Doing Our Best to Provide You the Best

OPERATORS MANUAL

## Introduction

Thank you for purchasing a Demco Hijacker hitch. We feel you have made a wise choice and hope you are completely satisfied with your new piece of equipment.

**Please consult vehicle owner's manual for 5th wheel towing instructions.**

### GENERAL INFORMATION

1. Unless otherwise specified, high-strength (grade 5) (3 radial-line head markings) hex head bolts are used throughout assembly of this piece of equipment.
2. Whenever the terms "**LEFT**" and "**RIGHT**" are used in this manual it means from a position behind the vehicle and facing forward.
3. When placing a parts order, refer to this manual for proper part numbers and place order by **PART NO. and DESCRIPTION.**

### **WARNING**

#### **Failure to follow these instructions may result in death or serious injury!**

- Trailer and its contents together must not exceed truck, hitch and/or trailer tow ratings.
- Towing vehicle must have a manufacturer's rated towing capacity equal to or greater than the gross trailer weight (dry weight of the trailer plus payload of the trailer).
- Gross weight of trailer must not exceed weight rating of hitch assembly.
- King pin weight must not exceed 4,000 pounds. If in doubt have king pin weight measured by qualified facility

## 5th Wheel Hitch Guidelines

1. Demco Hijacker hitches are designed for use with recreational fifth wheel trailers only.
2. Use only a SAE 2-inch king pin with your Demco Hijacker Fifth Wheel Hitch.
3. Approximately 15%-25% of trailer weight should be on hitch (Pin Weight).
4. Trucks come in many different configurations. Demco hitches are designed for use in light trucks such as the Ford F-Series, the Chevy Silverado and the Dodge Ram. Demco recommends the use of long bed (8ft) light trucks for the best combination in truck - trailer turning clearance.

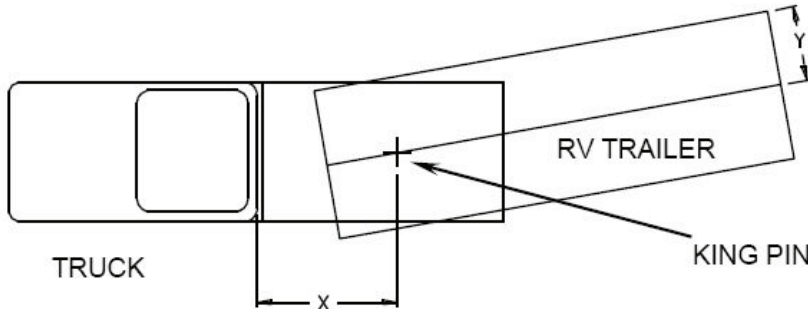

Rule of thumb: The distance from the back of the truck cab to the center of the rear truck axle ("X"), should be approximately 4 inches greater than one-half the trailer width ("Y")

5. If a short bed pickup (less than 8 ft. but longer than 6 ft.) is to be used for towing, Demco recommends the trailer be equipped with an extended pin box to help gain additional truck - trailer turning clearance (See trailer manufacturer for options). It also may be helpful to add a Demco Hijacker Ultra Slide for increased turning clearance for low speed, non- highway maneuvering.
6. The height of the hitch and the pin box should be adjusted so the trailer is approximately level as it is towed. Allow approximately 6 inches clearance between the top of the pickup walls and the underside of the front of the trailer for pitch and roll of the trailer. Allow more clearance between pickup walls and trailer for off road use.

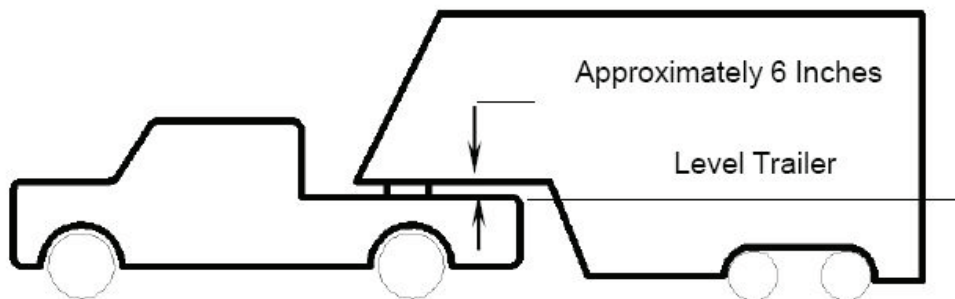

## Hijacker Double Pivot Head Assembly

The dampener stops the hitch head from flopping back and forth in the truck when the trailer is not hooked up. The urethane compresses under load so it does not restrict the fore and aft movement when coupled.

Before attaching the hitch head to the saddle assembly the urethane dampener will need to be installed. It is included in the bag with the bolt and nut for the hitch handle. Simply press into hole that is punched into the bottom side of the hitch as shown in **Figure A**.

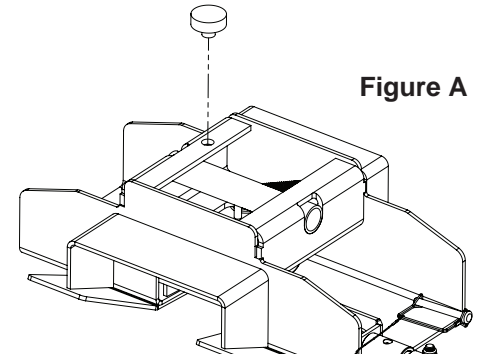
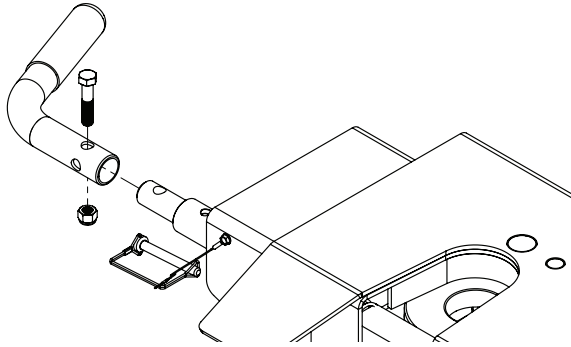

Figure A



**Note (Read carefully before installing):** Handle can be positioned toward the front or the back if it is found to interfere with the trailer in any way. Verify this before traveling.

1. Slide yellow gripped handle over locking bar, the handle may point forward, upward or backward. **\*\*DO NOT** have pointing upward if it is found to interfere with the trailer in any way during turning.
2. Fasten with 3/8" x 1 3/4" bolt and lock nut provided.

## WARNING

**DO NOT** install hitch handle in a position that the pin box could come in contact with or interfere with the latch of the hitch handle when turning! If the pin box contacts the hitch handle or its latch when turning, the trailer may become unhitched.

## Procedures to Close Locking Bar

Pull on handle with slight pressure while moving the secondary jaw to the right until the primary jaw is released. Slowly allow the handle to retract into the 5th wheel head. Caution: Do not put hands/fingers into the lock jaw area.

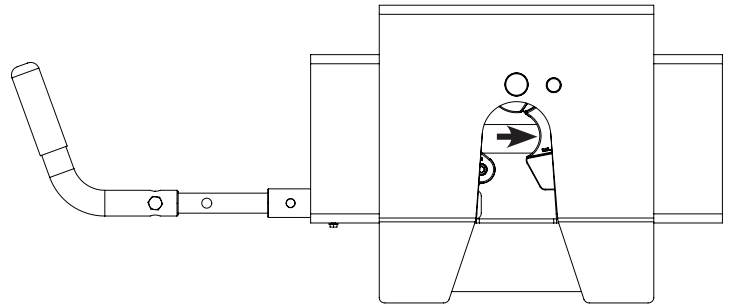

## Hijacker Pivot Head Maintenance

Each of our Hijacker fifth wheel hitches has been tested and pre-greased at our production facility to help ensure easy operation of your new product.

As it is a new piece of equipment with some moving parts, a period of wearing in may be necessary to facilitate smoother operation for your new fifth wheel hitch. The most important thing to remember is to keep all moving parts well greased and lubricated. Your doing this will help to ensure longer product life.

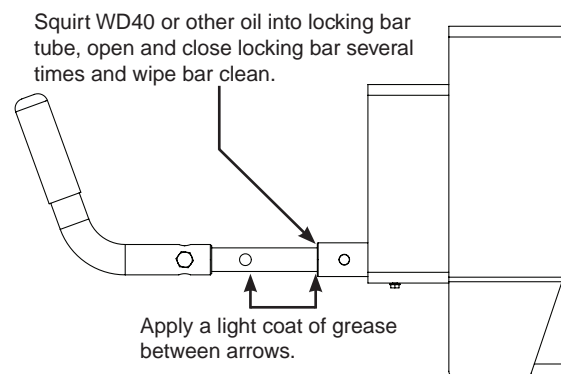
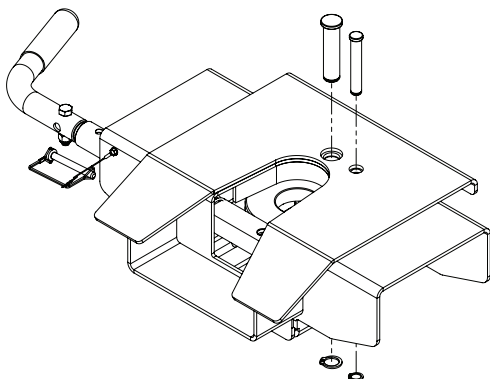

Jaw pins can be removed and greased by removing or unhooking jaw spring and both snap rings. Tap the pin up from bottom. Clean pins and inspect for wear, apply light coat of grease and reinstall pins, snap rings and spring.

## 5th Wheel Hitch Operation Instructions

### Coupling Procedure

1. Place wheel chock on each side of trailer wheels.
2. Adjust trailer jacks until trailer is a height for hook up. King pin plate should contact hitch approximately 1/2" below level.

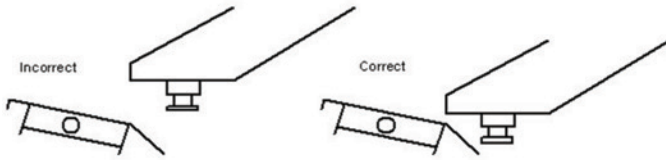

3. Lower tailgate of truck.
4. If hitch is in locked position, remove safety pin and pull handle out to the "Ready to Couple" position.
5. Line truck so that the hitch will accept king pin. Back truck up slowly towards trailer until king pin engages. Hitch will lock when king pin is fully engaged.
6. With the trailer coupled, visually check to see if hitch is completely locked by looking at the handle position, as well as visually checking to ensure that the jaw bar has traveled completely across the front of the king pin.
7. Place safety pin thru the tab and the hole in the handle. This will prevent handle from opening.
8. Connect power cable and breakaway switch cable between truck and trailer.
9. Close and latch tailgate.
10. Apply trailer brakes and try to pull forward slowly to double check that hitch is locked. Trailer should prevent truck from moving.
11. Completely raise trailer jacks. Check for proper clearance between truck box and trailer.
12. Pick up and store wheel chocks. You are now ready to travel.

### Uncoupling Procedure

1. Place wheel chocks on both sides of trailer wheels.
2. Lower trailer jacks to ground and extend until load is level with truck suspension. If on soft ground, place support under jack feet to prevent trailer from settling.
3. Lower tailgate on truck.
4. Disconnect power cable and break away switch.
5. Remove lock pin and pull handle out. If handle will not stay out, install safety pin in second handle hole just outside of frame handle bushing.
6. Drive truck slowly away from trailer.

### Very Important Maintenance Instructions

1. Inspect all fasteners for tightness at least every 2,000 miles of operation.
2. Inspect jaw and jaw bar for freedom of movement and proper operation before each use. Replace all damaged or worn parts.
3. Keep all moving parts of hitch well lubricated.
4. It is recommended to use grease or a 3/16" maximum Teflon disc to help prevent wear on top plate surface.

### Very Important Warnings

1. Know your vehicle and trailer GVWR and CVWR. DO NOT exceed capacity of hitch.
2. Hitch is for use with only a standard 2" king pin.

Safety pin MUST be fastened securely before moving vehicle and/or traveling

Ready to Couple

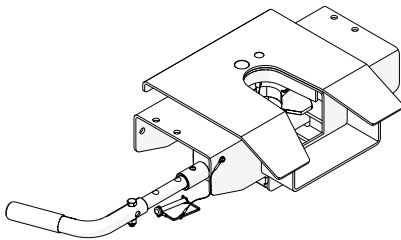

Remove safety lock pin if installed and pull handle until jaw locks open.

Coupled and Locked

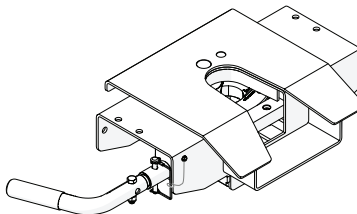

With handle in "Ready to Couple" position, back-up tow vehicle to couple trailer and hitch. Insert safety pin thru tab and hole in handle. NOTE: Ensure safety lock pin is inserted properly. Apply trailer brakes before jacks are raised and wheel chocks are removed.

Uncoupled & Locked

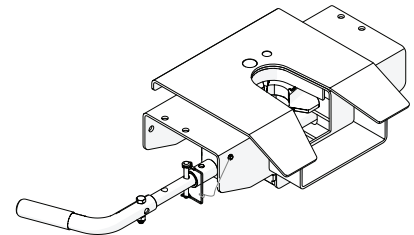

To uncouple, remove safety pin, pull handle straight out until the jaw locks open. Insert safety pin to lock open.

**VISUALLY INSPECT JAW LOCKING MECHANISM BEFORE TRAVELING**

# Pivot Head Parts Breakdown

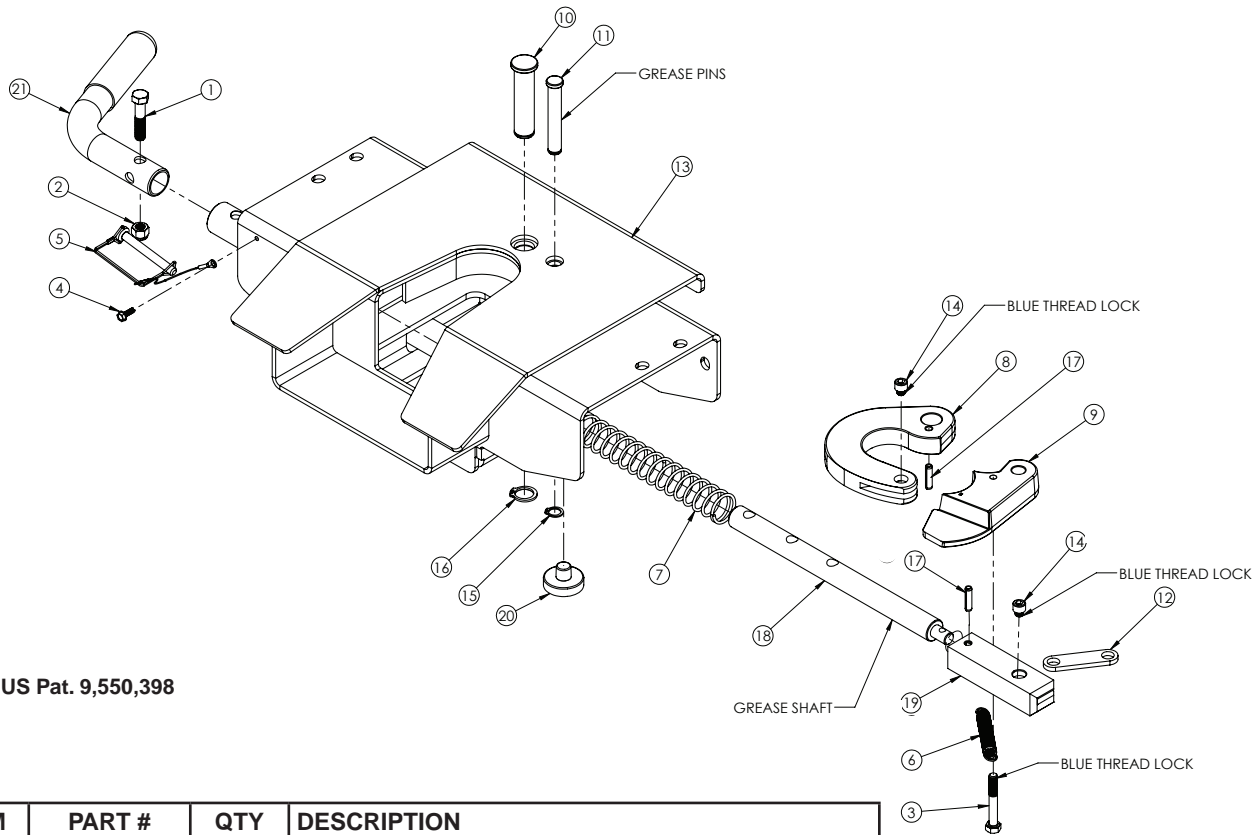

US Pat. 9,550,398

ITEM	PART #	QTY	DESCRIPTION
1	00908	1	BOLT, .375 NC X 1.75 HEX GR.5
2	02592	1	NUT, .375NC NYLON LOCK
3	03547	1	BOLT .313NC X 2.25 GR5 HEX
4	03787	1	SCREW #10NC X .50 SELF DRILLING HEX HD
5	05337	1	SAFTY LOCK PIN ASSEMBLY
6	14315	1	SPRING, TENSION, .063 WIRE X .50 OD X 2.75 FL
7	14385	1	SPRING COMPRESS .105 MW
8	14594-95	1	JAW HOOK
9	14595-95	1	SECONDARY LATCH JAW
10	14735-95	1	MAIN JAW PIN
11	14736-95	1	SECONDARY JAW PIN
12	14737-95	1	BAR/JAW LINK
13	14741-76	1	5TH WHEEL DOUBLE PIVOT HEAD
14	14747	2	SCREW .313NC X .25 SOCKET HD CAP
15	14749	1	SNAP RING EXT FOR .50 SHAFT
16	14750	1	SNAP RING EXT F/ .75SHAFT
17	14865	1	ROLL PIN, .25 X 1.00
18	14867-95	1	LEVER ARM BAR
19	14869-95	1	LOCK BAR
-	6094	-	LOCK BAR KIT (INCLUDES #19, #20 & #21)
20	15769	1	URETHANE BUMPER
21	15934	1	HANDLE ASSEMBLY

Please order replacement parts by PART NO. and DESCRIPTION.



*Doing Our Best to Provide You the Best*

HJ25990, Rev 5  
08/16

---

## 5TH WHEEL PIVOT SADDLE ASSEMBLIES

5990 (Ultra Series) Double Pivot & 6023 (Premier Series) Double Pivot

---

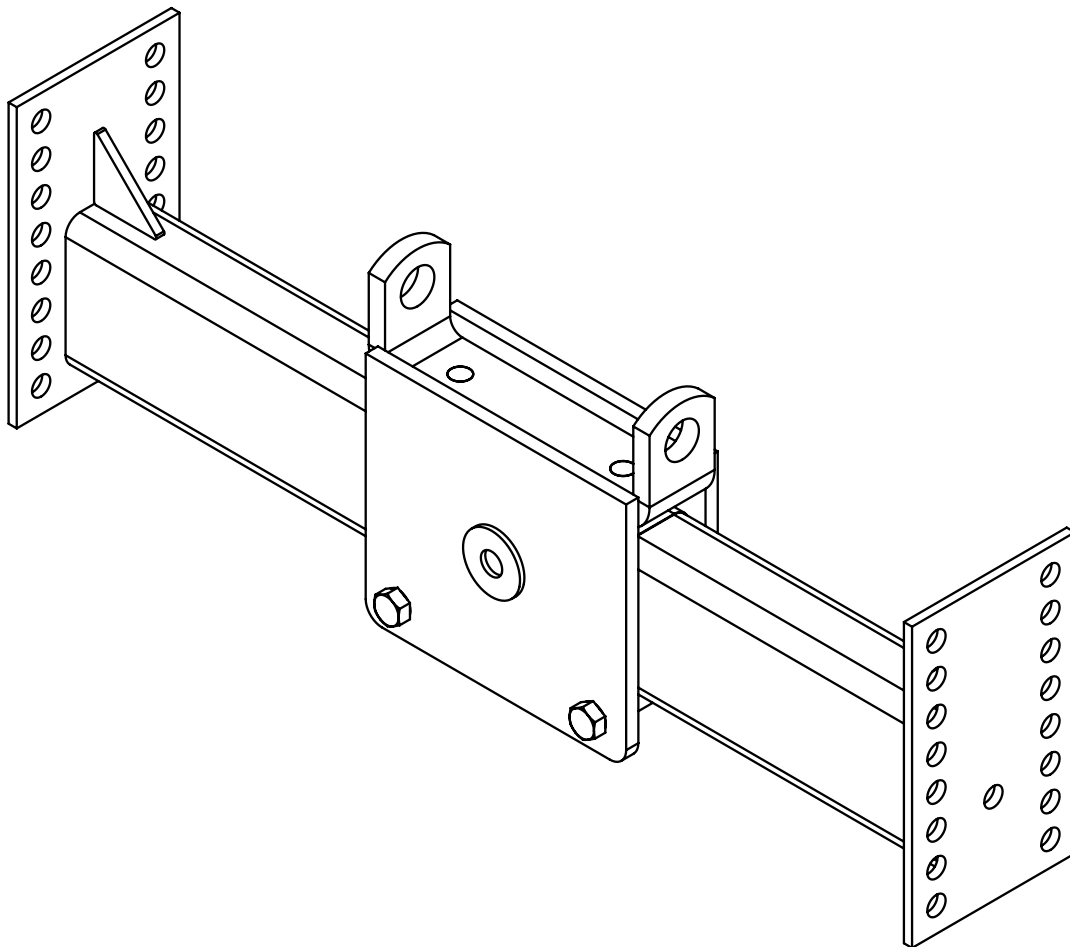

**OPERATOR MANUAL**



## Torque Specifications

### BOLT TORQUE DATA FOR STANDARD NUTS, BOLTS, AND CAPSCREWS.

Tighten all bolts to torques specified in chart unless otherwise noted. Check tightness of bolts periodically, using bolt chart as guide. Replace hardware with same grade bolt.

NOTE: Unless otherwise specified, high-strength Grade 5 hex bolts are used throughout assembly of equipment.

Torque figures indicated are valid for non-greased or non-oiled threads and heads unless otherwise specified. Therefore, do not grease or oil bolts or capscrews unless otherwise specified in this manual. When using locking elements, increase torque values by 5%.

\* GRADE or CLASS value for bolts and capscrews are identified by their head markings.

**Bolt Torque for Standard bolts \***

"A"	GRADE 2		GRADE 5		GRADE 8	
	lb-ft	(N.m)	lb-ft	(N.m)	lb-ft	(N.m)
1/4"	6	(8)	9	(12)	12	(16)
5/16"	10	(13)	18	(25)	25	(35)
3/8"	20	(27)	30	(40)	45	(60)
7/16"	30	(40)	50	(70)	80	(110)
1/2"	45	(60)	75	(100)	115	(155)
9/16"	70	(95)	115	(155)	165	(220)
5/8"	95	(130)	150	(200)	225	(300)
3/4"	165	(225)	290	(390)	400	(540)
7/8"	170	(230)	420	(570)	650	(880)
1"	225	(300)	630	(850)	970	(1310)

**Bolt Torque for Metric bolts \***

"A"	CLASS 8.8		CLASS 9.8		CLASS 10.9	
	lb-ft	(N.m)	lb-ft	(N.m)	lb-ft	(N.m)
6	9	(13)	10	(14)	13	(17)
7	15	(21)	18	(24)	21	(29)
8	23	(31)	25	(34)	31	(42)
10	45	(61)	50	(68)	61	(83)
12	78	(106)	88	(118)	106	(144)
14	125	(169)	140	(189)	170	(230)
16	194	(263)	216	(293)	263	(357)
18	268	(363)	--	--	364	(493)
20	378	(513)	--	--	515	(689)
22	516	(699)	--	--	702	(952)
24	654	(886)	--	--	890	(1206)

**5990 (ULTRA SERIES) & 6023 (PREMIER SERIES) DOUBLE PIVOT SADDLE ASSEMBLY**

The saddle bracket assembly (5990 & 6023) is preassembled at the factory. Attach to side rails by following hitch assembly instructions that accompany the side rails and base rails. Hitch attachment instructions are included in the 5th wheel head instructions.

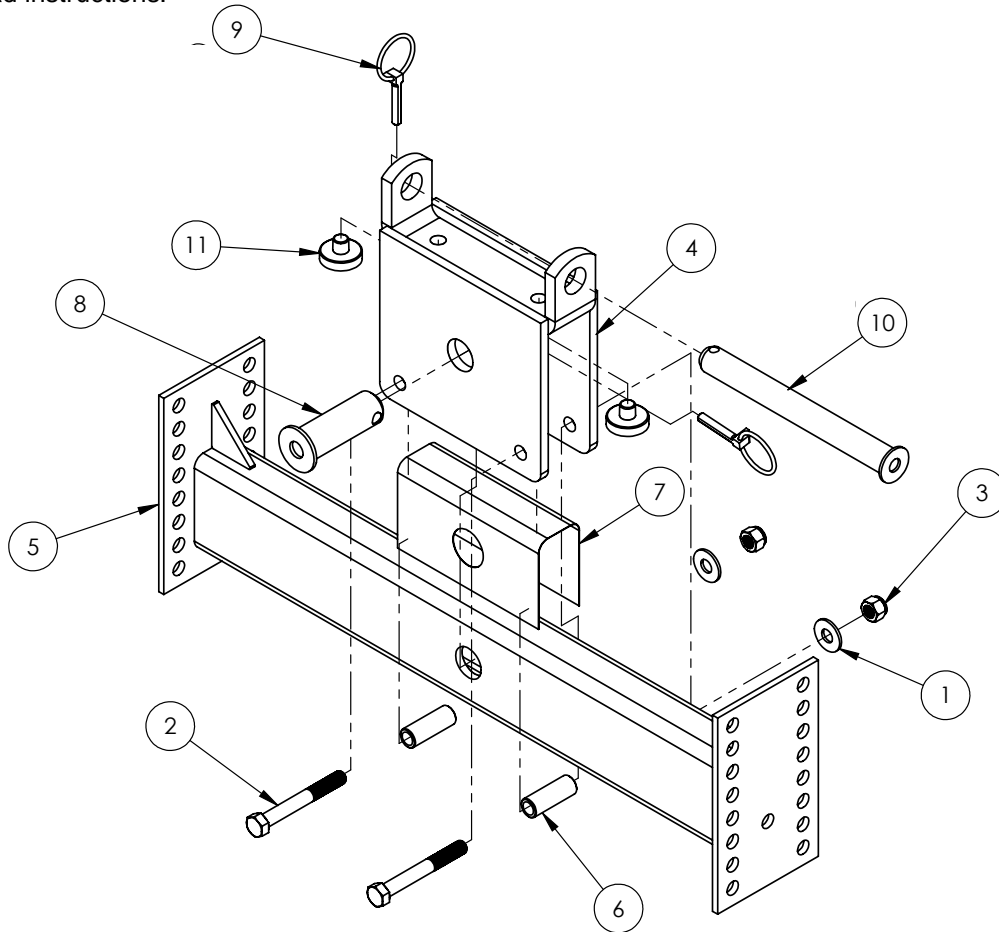

**5990 & 6023 Parts List**

ITEM	PART #	QTY	DESCRIPTION
1	00085	2	.50 FLAT WASHER
2	01896	2	BOLT, .50 NC X 4.00 HEX HEAD GR.5
3	02178	2	NUT, .50NC LOCK, NY. INSERT
4	14150-76	1	PIVOT SADDLE ASSEMBLY
5	14151-76	1	PIVOT SADDLE TUBE ASSY f/ ULTRA SERIES
-	14387-76	1	PIVOT SADDLE TUBE ASSY f/ PREMIER SERIES
6	14153-95	2	PIVOT SPACER BUSHING
7	14207	1	TEFLON SHIM
8	14209-95	1	PIVOT PIN ASSY.
9	14221	2	LYNCH PIN, .313
10	14222-95	1	PIVOT PIN 1"
11	15769	2	URETHANE BUMPER

**Please order replacement parts by PART NO. and DESCRIPTION.**

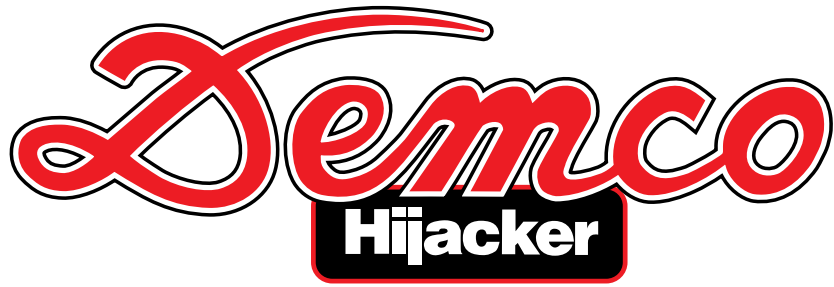

6/14  
HJ25987 Rev 1



# 5th Wheel Side Rail Assemblies

## 5987 SL SIDE RAIL

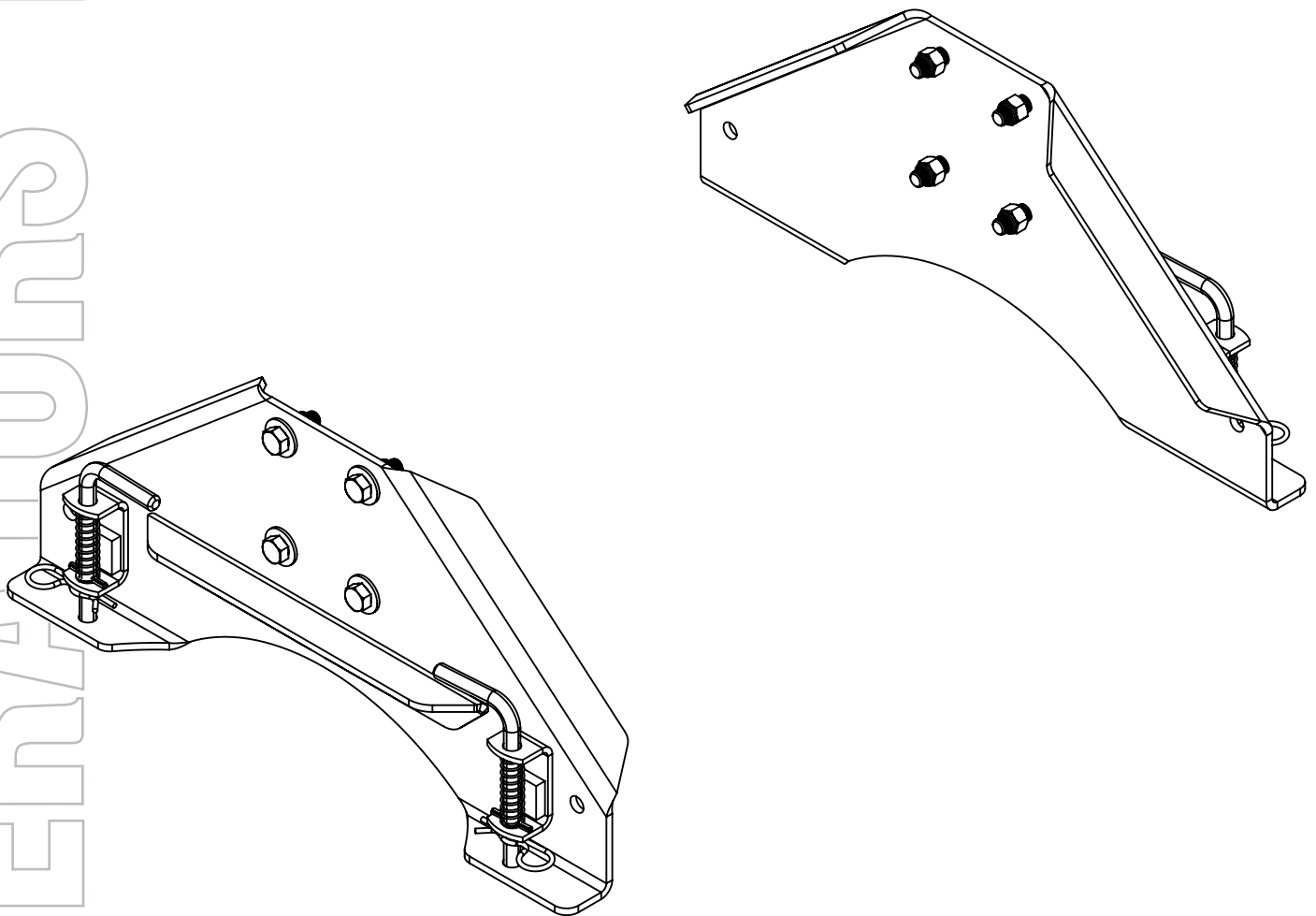

**READ** *complete manual CAREFULLY  
BEFORE attempting operation.*

Doing Our Best to Provide You the Best

MANUAL  
OPERATORS

# **Torque Specifications**

## **BOLT TORQUE DATA FOR STANDARD NUTS, BOLTS, AND CAPSCREWS.**

Tighten all bolts to torques specified in chart unless otherwise noted. Check tightness of bolts periodically, using bolt chart as guide. Replace hardware with same grade bolt.

NOTE: Unless otherwise specified, high-strength Grade 5 hex bolts are used throughout assembly of equipment.

Torque figures indicated are valid for non-greased or non-oiled threads and heads unless otherwise specified. Therefore, do not grease or oil bolts or capscrews unless otherwise specified in this manual. When using locking elements, increase torque values by 5%.

\* GRADE or CLASS value for bolts and capscrews are identified by their head markings.

**Bolt Torque for Standard bolts \***

"A"	GRADE 2		GRADE 5		GRADE 8	
	lb-ft	(N.m)	lb-ft	(N.m)	lb-ft	(N.m)
1/4"	6	(8)	9	(12)	12	(16)
5/16"	10	(13)	18	(25)	25	(35)
3/8"	20	(27)	30	(40)	45	(60)
7/16"	30	(40)	50	(70)	80	(110)
1/2"	45	(60)	75	(100)	115	(155)
9/16"	70	(95)	115	(155)	165	(220)
5/8"	95	(130)	150	(200)	225	(300)
3/4"	165	(225)	290	(390)	400	(540)
7/8"	170	(230)	420	(570)	650	(880)
1"	225	(300)	630	(850)	970	(1310)

**Bolt Torque for Metric bolts \***

"A"	CLASS 8.8		CLASS 9.8		CLASS 10.9	
	lb-ft	(N.m)	lb-ft	(N.m)	lb-ft	(N.m)
6	9	(13)	10	(14)	13	(17)
7	15	(21)	18	(24)	21	(29)
8	23	(31)	25	(34)	31	(42)
10	45	(61)	50	(68)	61	(83)
12	78	(106)	88	(118)	106	(144)
14	125	(169)	140	(189)	170	(230)
16	194	(263)	216	(293)	263	(357)
18	268	(363)	--	--	364	(493)
20	378	(513)	--	--	515	(689)
22	516	(699)	--	--	702	(952)
24	654	(886)	--	--	890	(1206)

## **5987 Parts Breakdown**

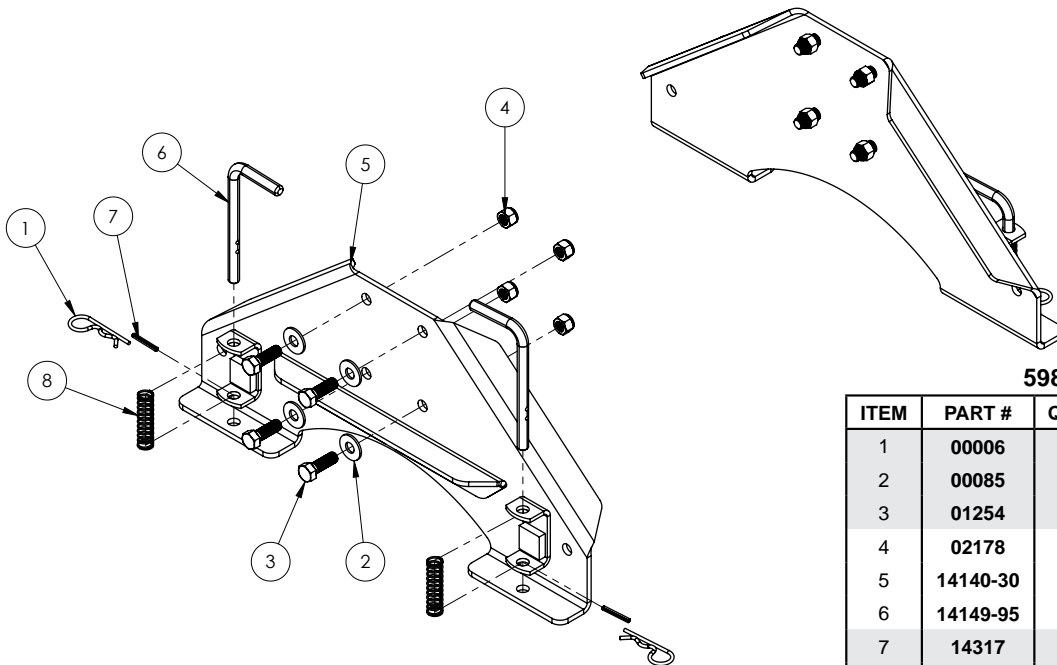

**5987 Parts Breakdown**

ITEM	PART #	QTY	DESCRIPTION
1	00006	4	HAIR PIN .148 WIRE X 3.06
2	00085	8	.50 FLAT WASHER
3	01254	8	BOLT, .50 NC X 1.50 GR.5 HEX
4	02178	8	NUT, .50NC LOCK, NY. INSERT
5	14140-30	2	5TH WHEEL SL SIDE RAIL
6	14149-95	4	SL PULL PIN
7	14317	4	PIN, ROLL, .188 X 1.50
8	14318	4	LATCH SPRING

Please order replacement parts by **PART NO.** and **DESCRIPTION.**

## 5987 Installation Instructions

The 5987 SL side rail kit is used for the "SL" 5th wheel hitch applications.

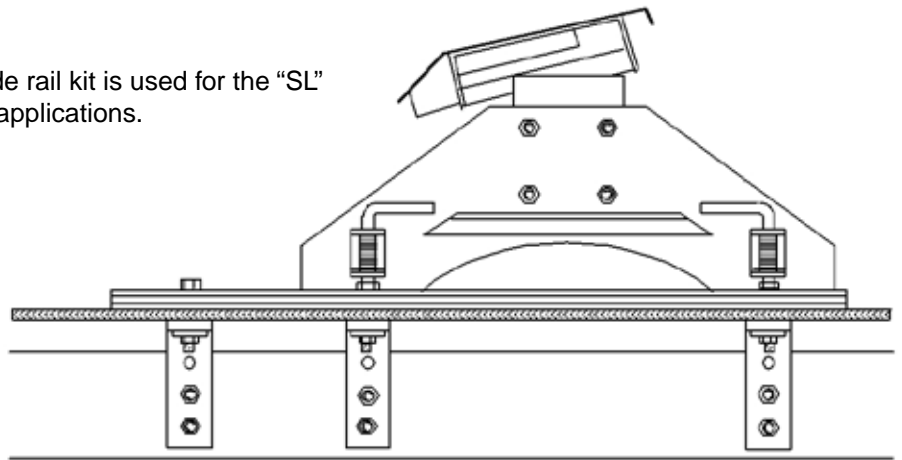

1. The correct height for the hitch is such that there is approximately 6" of clearance between the top of the truck box and the bottom of the trailer overhang. All Hijacker hitches have 4" of adjustment up or down in 1" increments.
2. Once the proper height has been determined, bolt the hitch saddle and side rail assemblies together and pin them into the bed rails. Pin the side rails into the set of holes closest to the end with the tab welded on it. This is the end of the bed rail that is mounted closest to the cab of the truck.
3. The ideal location for the center of the hitch is directly over the axle to up to 3" ahead of it, and it must be centered side to side in the box of the truck. As noted above, specific install instructions for the different vehicles are available.
4. When hitch and rail assembly are in the proper position, drill either the # 1 or # 2 hole (which ever the specific install instruction states to use) on one side first. Note that the # 1 hole is the hole closest to the cab of the truck and hole # 6 is closest to the tailgate. Drop in a 1/2" x 3" bolt (with flat washer) and loosely fasten a frame bracket up under the box with a square washer and 1/2" lock nut. Repeat this on the other bed rail. After the ends of the bed rails closest to the cab have been drilled and bolts dropped down thru, lift all four spring loaded lock pins up and turn to keep held up and slide the side rail assembly back toward the tailgate and lock into the rear set of holes. Drill either the # 5 or # 6 holes or the holes closest to the tailgate that are stated in the truck specific install instructions and drop a bolt and flat washer thru and repeat on the other side. Loosely fasten frame bracket and square washers onto the bolts under truck bed. Slide the hitch assembly back and forth in the bed rails to ensure smooth operation. Now proceed to drill at least one more hole per side in between the forward and rear bolts. And fasten frame brackets.
5. Securely fasten the frame brackets underneath by pushing them up against the frame and tightening up the nut. Next drill two holes thru the frame and use the 1/2" x 1 1/2" bolts, nuts, and flat washers to secure the brackets to the frame.

## SL Hitch Operation Instructions

The Hijacker "SL" fifth wheel assembly allows you to move your hitch back towards the tailgate of the truck in two increments of 4" each for a total of 8". This gives more clearance for the trailer to help make maneuvering the trailer (in reverse) easier for short box trucks.

**Important Note:** Never tow trailer in maneuvering position. Always tow with hitch pinned into the set of holes in the base rail that position the hitch above or slightly ahead of the axle. Never try to slide hitch back while coupled to trailer with SL model hitch.

To slide the hitch assembly from the towing position to the parking position, use the following procedure:

1. Place truck in park. Chock trailer wheels and lower trailer legs to raise trailer to proper height for uncoupling. Disconnect cables and uncouple trailer from hitch as per uncoupling instructions.
2. Pull the truck ahead far enough to move hitch (approximately 24").
3. Get up in truck box and unclip the 4 hitch pins that are inserted into the spring loaded locking pins.
4. Pull up the 4 pins all the way and turn the pin 90° to lock in the up position.
5. Slide the hitch back towards the tailgate of the truck and position over the set of holes you would like to use for extra clearance
6. Turn the pins back 90° and the spring pressure will drop them down into the holes in the base rails.

1. Make sure that the pins are completely engaged in the holes as far as they can go.
2. Insert the hitch pins into the holes in the spring loaded pins, under the spring bracket, to lock them into position.
3. Return to cab of truck and recouple the trailer following the coupling instructions. Refasten trailer cables.
4. The trailer is now ready to maneuver into position with sufficient cab clearance.

**To Lock in Place:**

1. Line spring pin up over holes in bed rail.
2. Turn handle to release.
3. Make sure pin is down all the way.
4. Install hitch pin to lock.

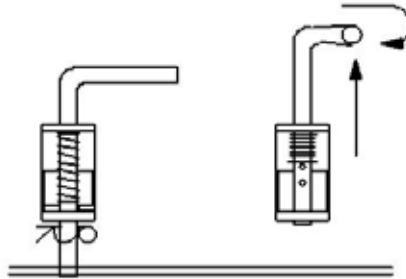

**To Move Side Rails:**

1. Remove hitch pin.
2. Lift up on handle.
3. Turn to keep handle in up position.

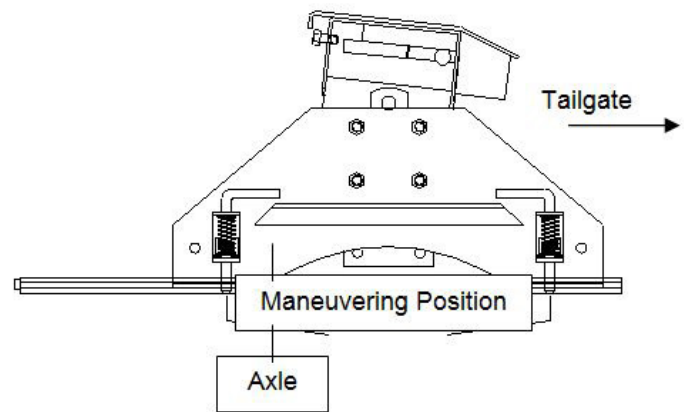
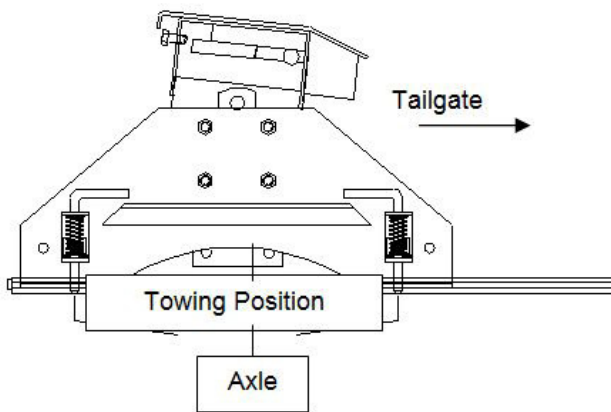

MANUAL  
OPERATORS



1-13  
HJ25991 rev 2



# 5th Wheel Hitch

## 5991 21K STATIONARY UPGRADE KIT

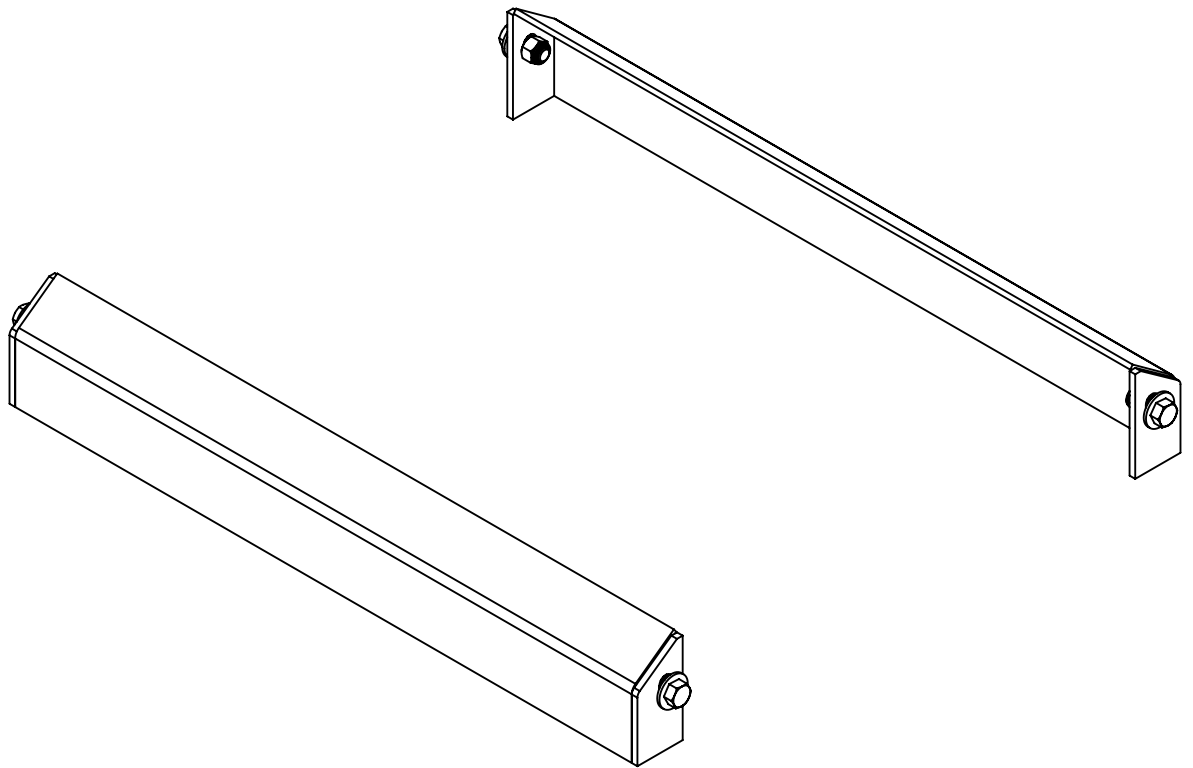

**READ** *complete manual CAREFULLY  
BEFORE attempting operation.*

Doing Our Best to Provide You the Best



## **Torque Specifications**

### **BOLT TORQUE DATA FOR STANDARD NUTS, BOLTS, AND CAPSCREWS.**

Tighten all bolts to torques specified in chart unless otherwise noted. Check tightness of bolts periodically, using bolt chart as guide. Replace hardware with same grade bolt.

NOTE: Unless otherwise specified, high-strength Grade 5 hex bolts are used throughout assembly of equipment.

Torque figures indicated are valid for non-greased or non-oiled threads and heads unless otherwise specified. Therefore, do not grease or oil bolts or capscrews unless otherwise specified in this manual. When using locking elements, increase torque values by 5%.

\* GRADE or CLASS value for bolts and capscrews are identified by their head markings.

**Bolt Torque for Standard bolts \***

"A"	GRADE 2		GRADE 5		GRADE 8	
	lb-ft	(N.m)	lb-ft	(N.m)	lb-ft	(N.m)
1/4"	6	(8)	9	(12)	12	(16)
5/16"	10	(13)	18	(25)	25	(35)
3/8"	20	(27)	30	(40)	45	(60)
7/16"	30	(40)	50	(70)	80	(110)
1/2"	45	(60)	75	(100)	115	(155)
9/16"	70	(95)	115	(155)	165	(220)
5/8"	95	(130)	150	(200)	225	(300)
3/4"	165	(225)	290	(390)	400	(540)
7/8"	170	(230)	420	(570)	650	(880)
1"	225	(300)	630	(850)	970	(1310)

**Bolt Torque for Metric bolts \***

"A"	CLASS 8.8		CLASS 9.8		CLASS 10.9	
	lb-ft	(N.m)	lb-ft	(N.m)	lb-ft	(N.m)
6	9	(13)	10	(14)	13	(17)
7	15	(21)	18	(24)	21	(29)
8	23	(31)	25	(34)	31	(42)
10	45	(61)	50	(68)	61	(83)
12	78	(106)	88	(118)	106	(144)
14	125	(169)	140	(189)	170	(230)
16	194	(263)	216	(293)	263	(357)
18	268	(363)	--	--	364	(493)
20	378	(513)	--	--	515	(689)
22	516	(699)	--	--	702	(952)
24	654	(886)	--	--	890	(1206)

## 5991 21K Upgrade Kit Assembly Instructions

The addition of these side load brackets to the Premier/UL and SL series fifth wheel hitches will boost the overall capacity rating of the hitch from 16,000 lbs. to 21,000 lbs. towing capacity.

1. Loosely assemble complete fifth wheel hitch assembly and attach the 5991 brackets, using fasteners provided in kit, to the side rails in front of and behind the hitch as shown below.
2. Replace the 16K decals with the new 21K decals that are provided with the upgrade kit over top of existing decals.
3. Tighten all bolts.

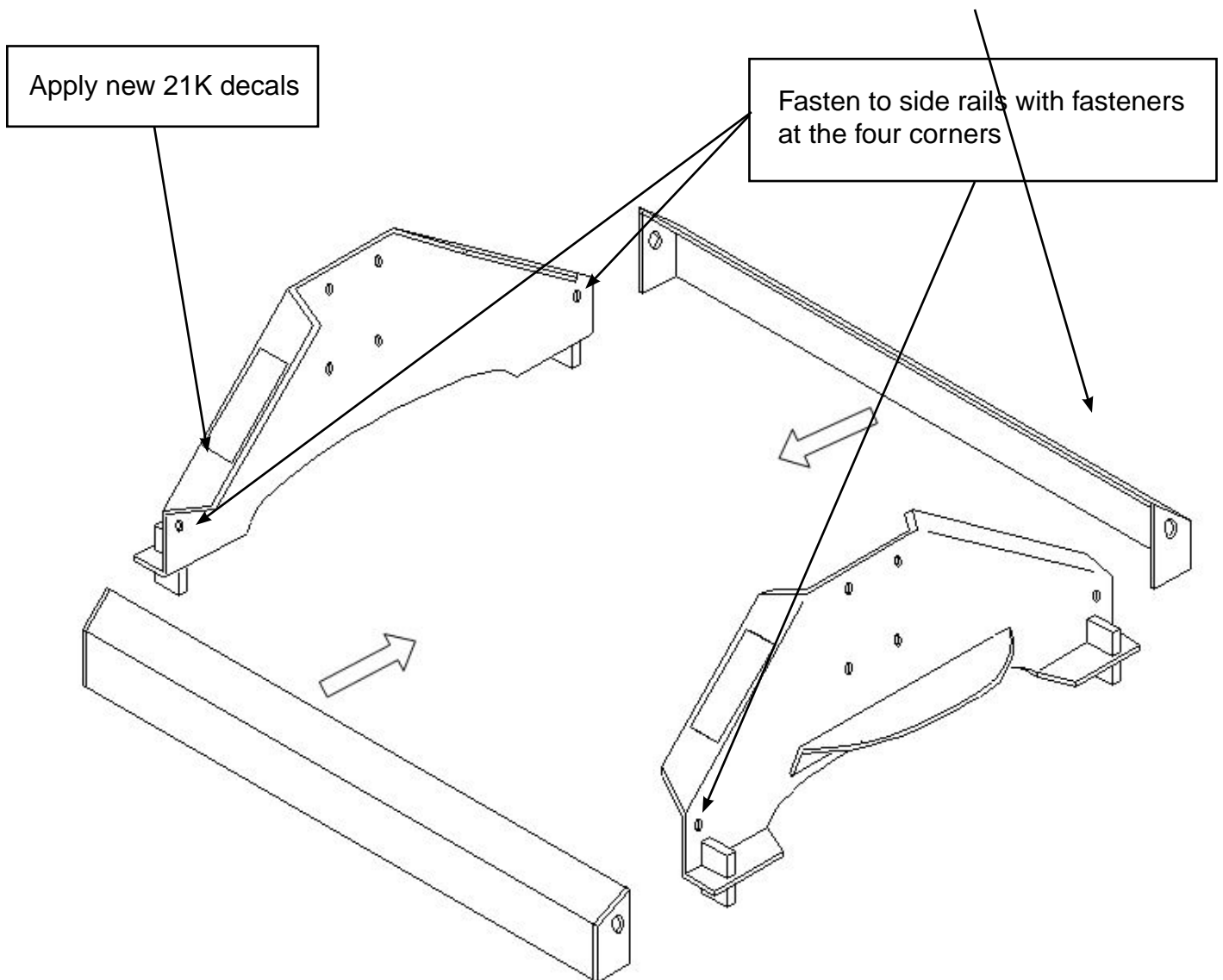

## 5991 Parts Breakdown

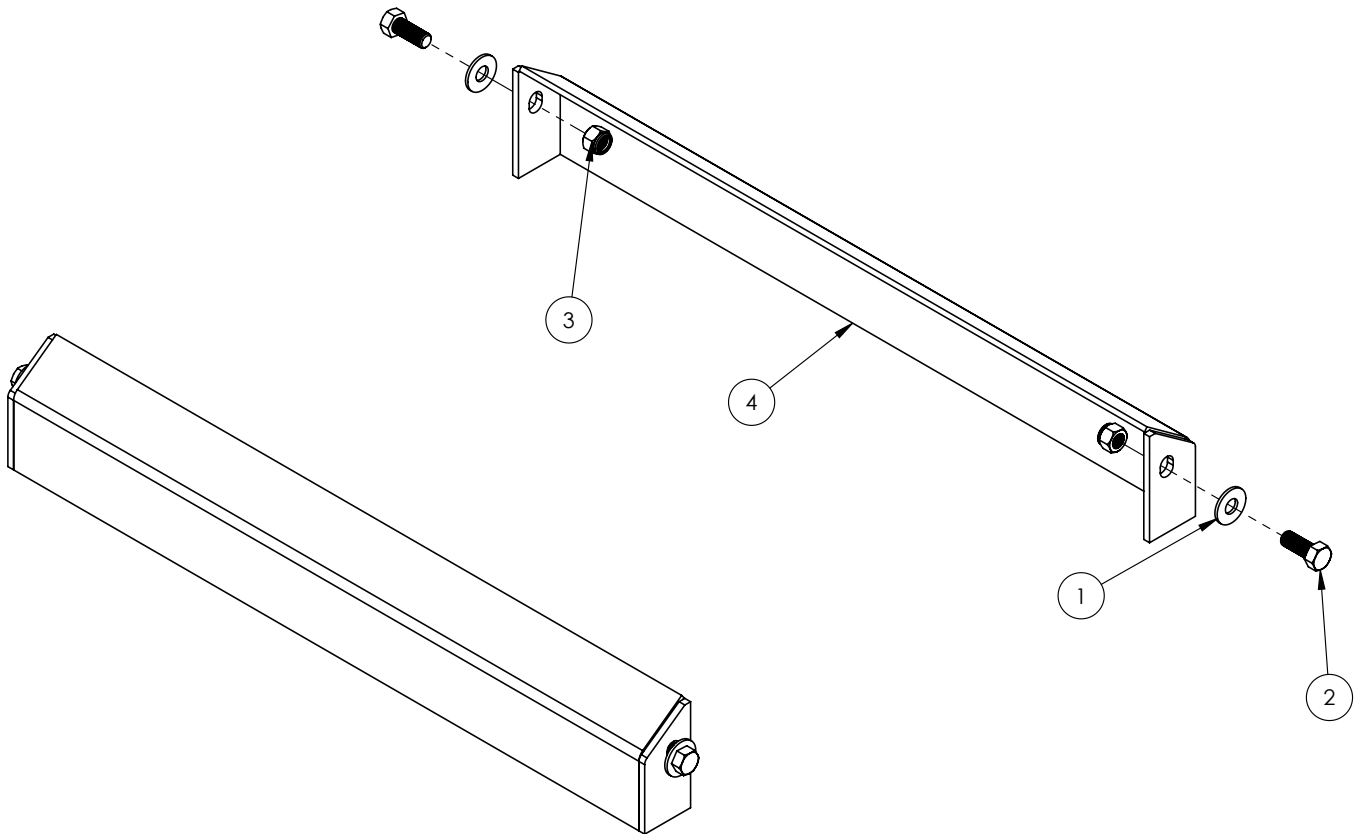

### 5991 Parts Breakdown

ITEM	PART #	QTY	DESCRIPTION
1	00085	4	.50 FLAT WASHER
2	01254	4	BOLT, .50NC X 1.50
3	02178	4	NUT, .50NC LOCK, NY. INSERT
4	14162-76	2	21K BRACE

Please order replacement parts by PART NO. and DESCRIPTION.



# 5th Wheel Bed Rails

## 6012 SL Bed Rail

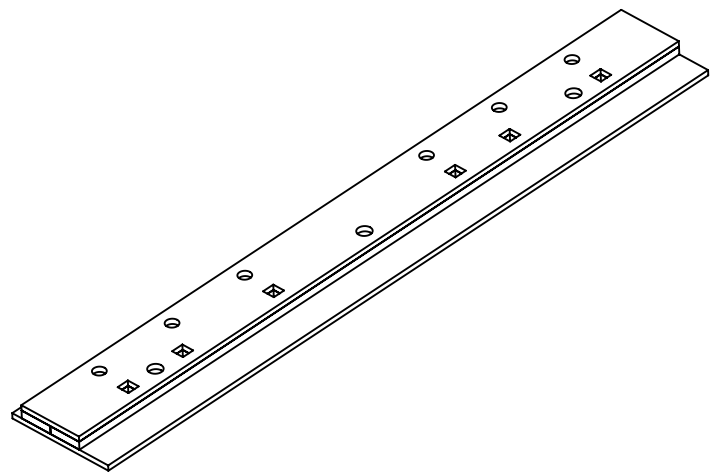
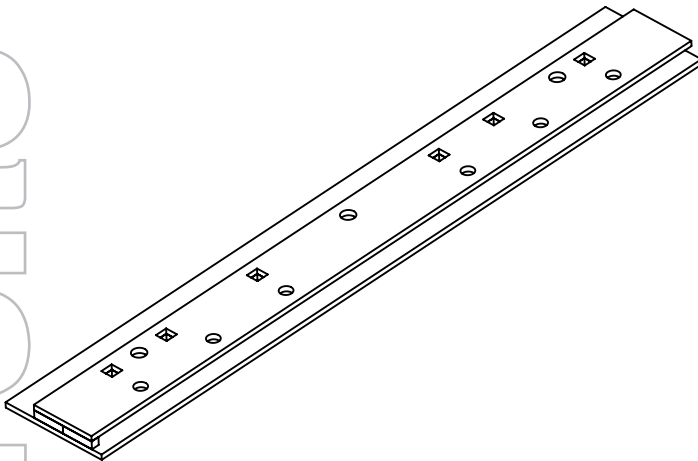

**READ** *complete manual CAREFULLY  
BEFORE attempting operation.*

Doing Our Best to Provide You the Best

MANUAL  
OPERATORS

**BOLT TORQUE DATA FOR STANDARD NUTS, BOLTS, AND CAPSCREWS.**

Tighten all bolts to torques specified in chart unless otherwise noted. Check tightness of bolts periodically, using bolt chart as guide. Replace hardware with same grade bolt.

NOTE: Unless otherwise specified, high-strength Grade 5 hex bolts are used throughout assembly of equipment.

Torque figures indicated are valid for non-greased or non-oiled threads and heads unless otherwise specified. Therefore, do not grease or oil bolts or capscrews unless otherwise specified in this manual. When using locking elements, increase torque values by 5%.

\* GRADE or CLASS value for bolts and capscrews are identified by their head markings.

**Bolt Torque for Standard bolts \***

"A"	GRADE 2		GRADE 5		GRADE 8	
	lb-ft	(N.m)	lb-ft	(N.m)	lb-ft	(N.m)
1/4"	6	(8)	9	(12)	12	(16)
5/16"	10	(13)	18	(25)	25	(35)
3/8"	20	(27)	30	(40)	45	(60)
7/16"	30	(40)	50	(70)	80	(110)
1/2"	45	(60)	75	(100)	115	(155)
9/16"	70	(95)	115	(155)	165	(220)
5/8"	95	(130)	150	(200)	225	(300)
3/4"	165	(225)	290	(390)	400	(540)
7/8"	170	(230)	420	(570)	650	(880)
1"	225	(300)	630	(850)	970	(1310)

**Bolt Torque for Metric bolts \***

"A"	CLASS 8.8		CLASS 9.8		CLASS 10.9	
	lb-ft	(N.m)	lb-ft	(N.m)	lb-ft	(N.m)
6	9	(13)	10	(14)	13	(17)
7	15	(21)	18	(24)	21	(29)
8	23	(31)	25	(34)	31	(42)
10	45	(61)	50	(68)	61	(83)
12	78	(106)	88	(118)	106	(144)
14	125	(169)	140	(189)	170	(230)
16	194	(263)	216	(293)	263	(357)
18	268	(363)	--	--	364	(493)
20	378	(513)	--	--	515	(689)
22	516	(699)	--	--	702	(952)
24	654	(886)	--	--	890	(1206)

**6012 Parts Breakdown**

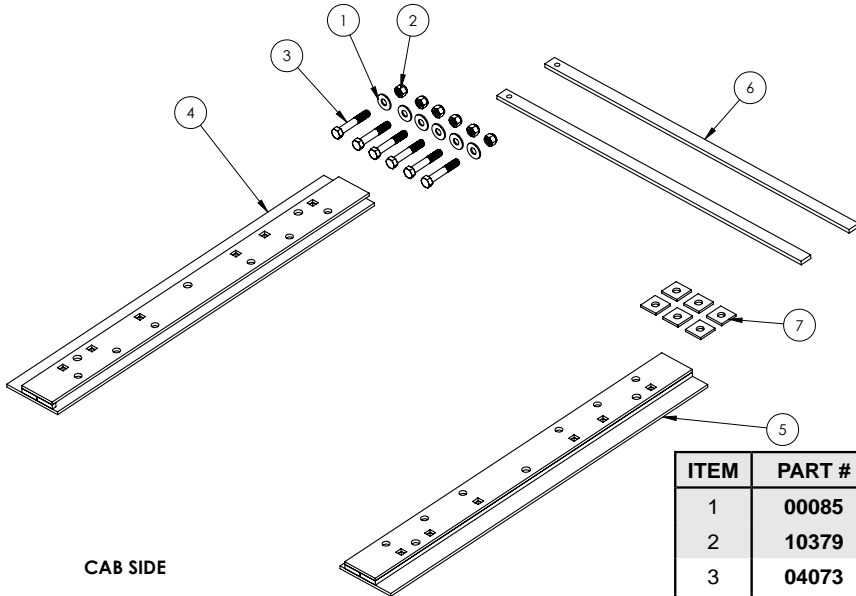

ITEM	PART #	QTY	DESCRIPTION
1	00085	6	.50 FLAT WASHER
2	10379	6	NUT, .50NC SERRATED FLANGE
3	04073	6	BOLT .50NC X 3.00 GR5 HEX
4	14141-76	1	SL BASE RAIL, RIGHT
5	14142-76	1	SL BASE RAIL, LEFT
6	14218-76	2	SL SHIM
7	14235-95	6	SQUARE WASHER

Please order replacement parts by PART NO. and DESCRIPTION.

# 6012 Installation Instructions

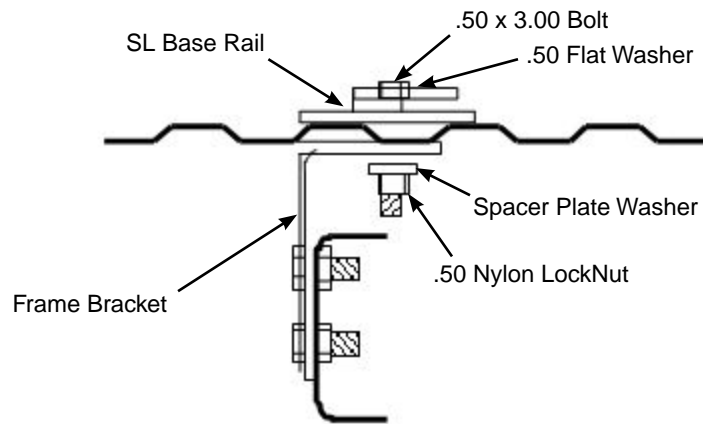
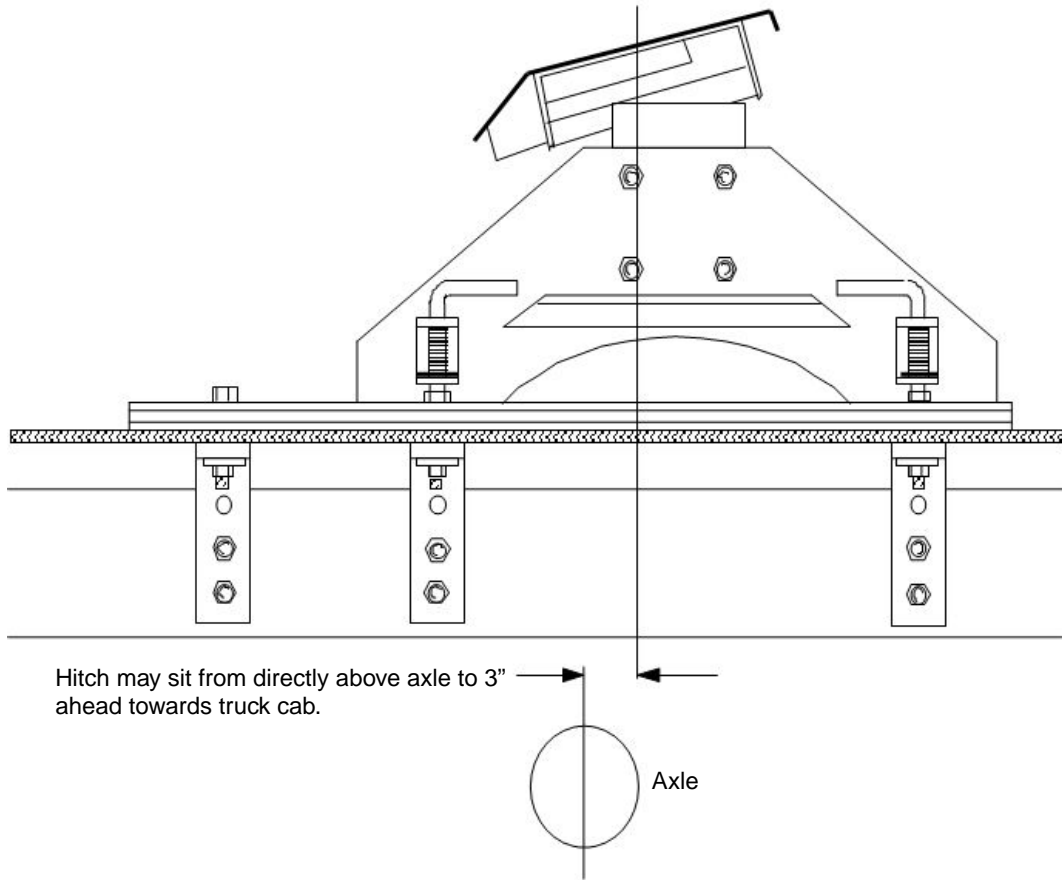

**IMPORTANT NOTICE:** This installation may require different frame brackets for the various truck models. This kit does not contain any frame brackets for this reason.

The Hijacker hitch must be completely assembled and adjusted to the proper height before securing into the box of the truck. Never tow with the hitch in the maneuvering or parking position.

1. The correct height for the hitch is such that there is approximately 6" of clearance between the top of the truck box and the bottom of the trailer overhang. All Hijacker hitches have 4" of adjustment up or down in 1" increments.
2. Once the proper height has been determined, bolt the hitch saddle and side rail assemblies together and pin them into the bed rails. Pin the side rails into the set of holes closest to the end with the tab welded on it. This is the end of the bed rail that is mounted closest to the cab of the truck.
3. The ideal location for the center of the hitch is directly over the axle to up to 3" ahead of it, and it must be centered side to side in the box of the truck. As noted above, specific install instructions for the different vehicles are available. **NOTE:** Use supplied shim (#14218-76) if rail only sits on one rib of pickup box. Shim will be used to support the rail. Place shim between ribs of pickup box and center front to back of rail.
4. When hitch and rail assembly are in the proper position, drill either the # 1 or # 2 hole (which ever the specific install instruction states to use) on one side first. Note that the # 1 hole is the hole closest to the cab of the truck and hole # 6 is closest to the tailgate. Drop in a ½" x 3" bolt (with flat washer) and loosely fasten a frame bracket up under the box with a square washer and ½" flange nut. Repeat this on the other bed rail. After the ends of the bed rails closest to the cab have been drilled and bolts dropped down thru, lift all four spring loaded lock pins up and turn to keep held up and slide the side rail assembly back toward the tailgate and lock into the rear set of holes. Drill either the # 5 or # 6 holes or the holes closest to the tailgate that are stated in the truck specific install instructions and drop a bolt and flat washer thru and repeat on the other side. Loosely fasten frame bracket and square washers onto the bolts under truck bed. Slide the hitch assembly back and forth in the bed rails to ensure smooth operation. Now proceed to drill at least one more hole per side in between the forward and rear bolts. And fasten frame brackets.
5. Securely fasten the frame brackets underneath by pushing them up against the frame and tightening up the nut. Next drill two holes thru the frame and use the ½" x 1 ½" bolts, nuts, and flat washers to secure the brackets to the frame. **IT IS IMPORTANT TO USE 6 L-SHAPED FRAME BRACKETS OR VEHICLES SPECIFIC FRAME BRACKETS.**