



Doing Our Best to Provide You the Best

HJ26071, Rev 6
03/18

5TH WHEEL BED RAILS

6071 Premier/UL Bed Rail Industry Standard

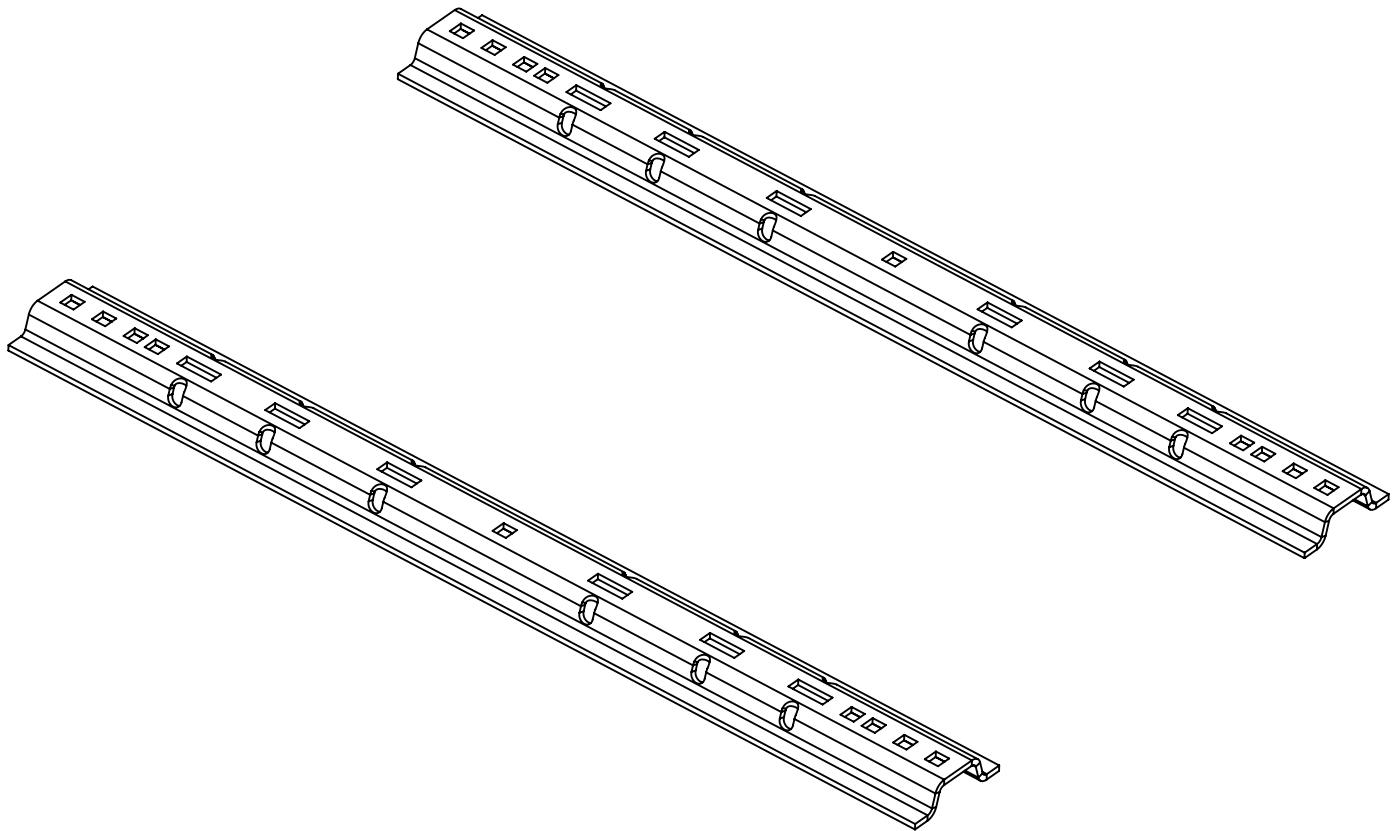

OPERATOR MANUAL



Torque Specifications

BOLT TORQUE DATA FOR STANDARD NUTS, BOLTS, AND CAPSCREWS.

Tighten all bolts to torques specified in chart unless otherwise noted. Check tightness of bolts periodically, using bolt chart as guide. Replace hardware with same grade bolt.

NOTE: Unless otherwise specified, high-strength Grade 5 hex bolts are used throughout assembly of equipment.

Torque figures indicated are valid for non-greased or non-oiled threads and heads unless otherwise specified. Therefore, do not grease or oil bolts or capscrews unless otherwise specified in this manual. When using locking elements, increase torque values by 5%.

* GRADE or CLASS value for bolts and capscrews are identified by their head markings.

Bolt Torque for Standard bolts *

"A"	GRADE 2		GRADE 5		GRADE 8	
	lb-ft	(N.m)	lb-ft	(N.m)	lb-ft	(N.m)
1/4"	6	(8)	9	(12)	12	(16)
5/16"	10	(13)	18	(25)	25	(35)
3/8"	20	(27)	30	(40)	45	(60)
7/16"	30	(40)	50	(70)	80	(110)
1/2"	45	(60)	75	(100)	115	(155)
9/16"	70	(95)	115	(155)	165	(220)
5/8"	95	(130)	150	(200)	225	(300)
3/4"	165	(225)	290	(390)	400	(540)
7/8"	170	(230)	420	(570)	650	(880)
1"	225	(300)	630	(850)	970	(1310)

Bolt Torque for Metric bolts *

"A"	CLASS 8.8		CLASS 9.8		CLASS 10.9	
	lb-ft	(N.m)	lb-ft	(N.m)	lb-ft	(N.m)
6	9	(13)	10	(14)	13	(17)
7	15	(21)	18	(24)	21	(29)
8	23	(31)	25	(34)	31	(42)
10	45	(61)	50	(68)	61	(83)
12	78	(106)	88	(118)	106	(144)
14	125	(169)	140	(189)	170	(230)
16	194	(263)	216	(293)	263	(357)
18	268	(363)	--	--	364	(493)
20	378	(513)	--	--	515	(689)
22	516	(699)	--	--	702	(952)
24	654	(886)	--	--	890	(1206)

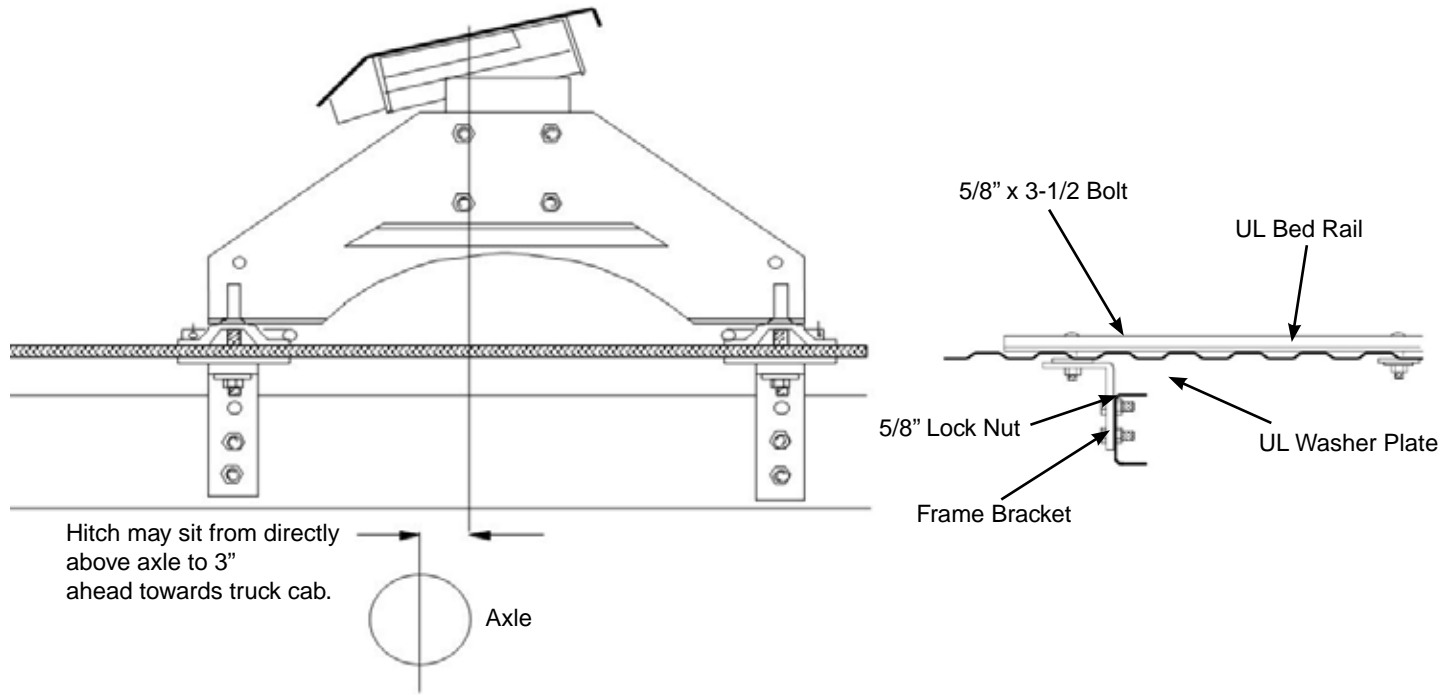

IMPORTANT NOTICE: This installation may require different frame brackets for the various truck models. This kit does not contain any frame brackets for this reason.

The Hijacker hitch must be completely assembled and adjusted to the proper height before securing into the box of the truck. Never tow with the hitch in the maneuvering or parking position (sliding models only).

1. The correct height for the hitch is such that there is approximately 6" of clearance between the top of the truck box and the bottom of the trailer overhang. All Hijacker hitches have 4" of adjustment up or down in 1" increments.
2. Once the proper height has been determined, bolt the hitch saddle and side rail assemblies together and pin them into the bed rails.
3. The ideal location for the center of the hitch is directly over the axle to up to 3" ahead of it, and it must be centered side to side in the box of the truck. As noted above, specific install instructions for the different vehicles are available.
4. When hitch and rail assembly are in the proper position, make sure that the bed rails are parallel to each other. Drill four 5/8" holes, 2 per bed rail, through the bed of the truck using the square holes as guides. There are 4 square holes on the ends of the bed rails to choose from. The most commonly used hole is the outer hole, but some installations may require using the middle holes or the inner most hole. Check the distance of the truck frame at the point where the bed rails sit above it to determine the best holes to use or use which ever holes the specific install instruction states to use (see Important Notice above). Drop in a 5/8" x 3 1/2" hex bolt or 5/8" x 3 1/2" carriage bolt through the holes as they are drilled to prevent any movement during installation.
5. Securely fasten the frame brackets underneath (see other side of page) by pushing them up against the frame and tightening up the nut. Next drill two holes thru the frame and use the 1/2" x 1 1/2" bolts, nuts, and flat washers to secure the brackets to the frame. **IT IS IMPORTANT TO USE 4 L SHAPED FRAME BRACKETS OR VEHICLE SPECIFIC FRAME BRACKETS.**

Ultra Hitch Install Shims

Due to some of the configurations of corrugations in the bed of the box, we supply for use 4 - 3/8" x 1 1/2" x 5" spacers to prevent the box from collapsing in slightly during tightening of the bolts that go down through the box. With the space between the ribs wider and taller on some trucks, the end of the base rails do not span across the valley of the ribs creating a potential for crushing. The following procedures are recommended.

**The use of the UL FB washers is not needed when using the 3/8" spacers for these installations.

Extra 3/8" x 1 1/2" x 5" shims are available from Demco so they can be stocked by the dealer/installers along with any optional frame brackets.

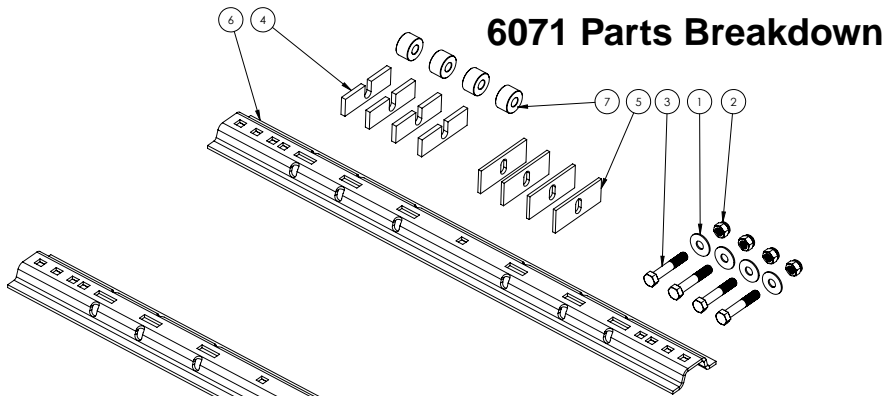
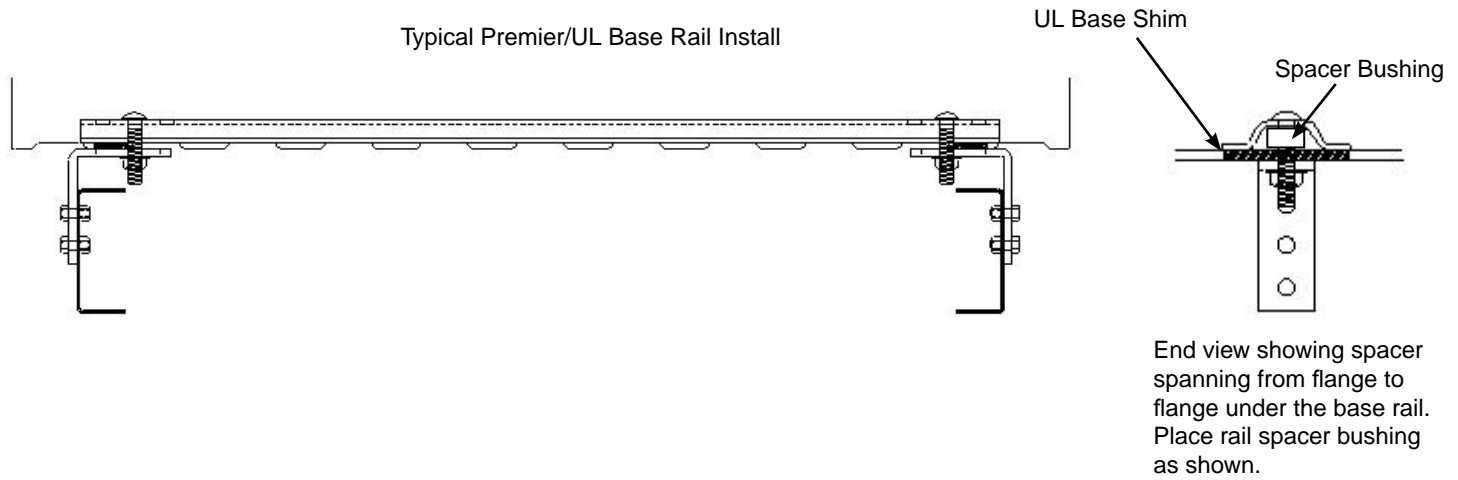

DEMCO

ITEM	PART #	QTY	DESCRIPTION
1	00477	4	WASHER, FLAT, .625
2	14283	4	NUT, .625NC SERRATED FLANGE HEX
3	05103	4	.625NC X 3.50 HEX BOLT
-	14321	4	.625NC x 3.50 CARRIAGE BOLT (NOT SHOWN)
4	14156-95	4	UL BASE SHIM
5	14157-95	4	UL FB WASHER
6	14620-76	2	UL STANDARD PREMIER BASE RAIL
7	15182	4	RAIL SPACER BUSHINGS

Please order replacement parts by PART NO. and DESCRIPTION

