

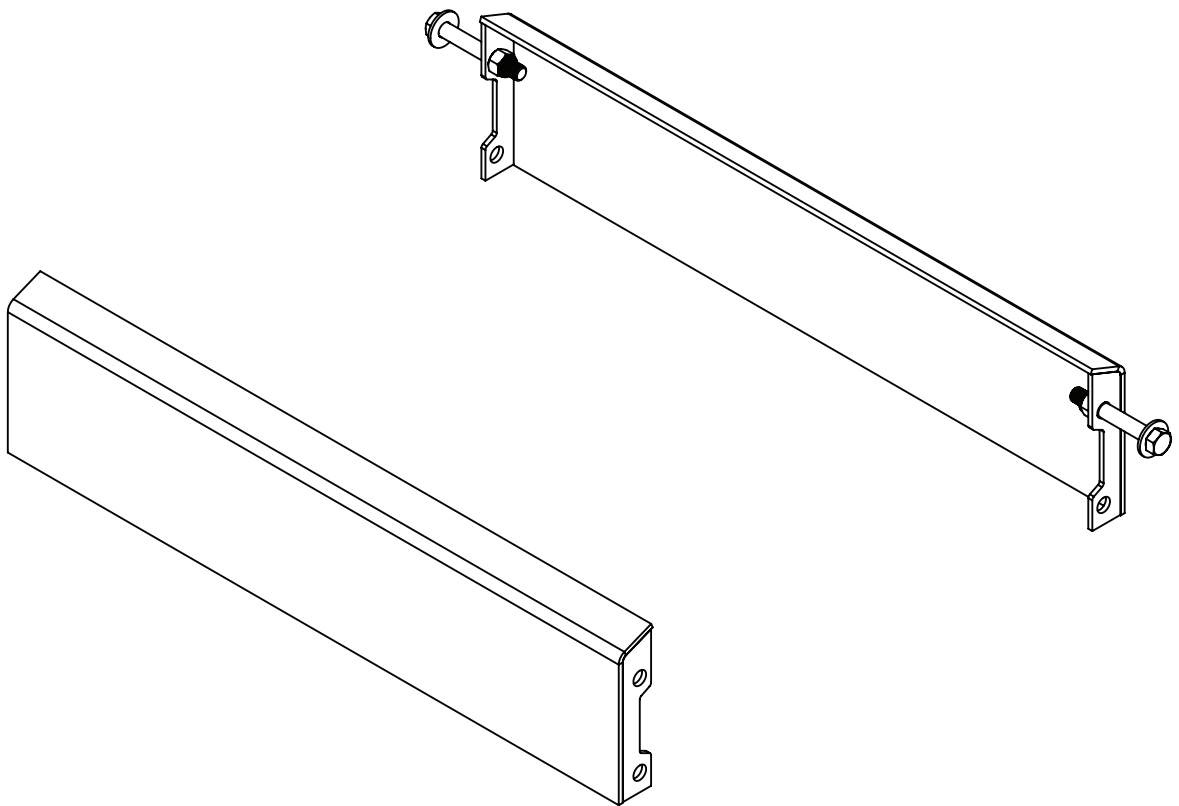

# 5th Wheel Hitch

## 6052 PREMIER SERIES

### ULTRA SLIDE UPGRADE KIT



**READ** *complete manual CAREFULLY  
BEFORE attempting operation.*

Please consult vehicle owner's manual for 5th wheel towing instructions.



## Torque Specifications

### **BOLT TORQUE DATA FOR STANDARD NUTS, BOLTS, AND CAPSCREWS.**

Tighten all bolts to torques specified in chart unless otherwise noted. Check tightness of bolts periodically, using bolt chart as guide. Replace hardware with same grade bolt.

NOTE: Unless otherwise specified, high-strength Grade 5 hex bolts are used throughout assembly of equipment.

Torque figures indicated are valid for non-greased or non-oiled threads and heads unless otherwise specified. Therefore, do not grease or oil bolts or capscrews unless otherwise specified in this manual. When using locking elements, increase torque values by 5%.

\* GRADE or CLASS value for bolts and capscrews are identified by their head markings.

### **Bolt Torque for Standard bolts \***

"A"	GRADE 2		GRADE 5		GRADE 8	
	lb-ft	(N.m)	lb-ft	(N.m)	lb-ft	(N.m)
1/4"	6	(8)	9	(12)	12	(16)
5/16"	10	(13)	18	(25)	25	(35)
3/8"	20	(27)	30	(40)	45	(60)
7/16"	30	(40)	50	(70)	80	(110)
1/2"	45	(60)	75	(100)	115	(155)
9/16"	70	(95)	115	(155)	165	(220)
5/8"	95	(130)	150	(200)	225	(300)
3/4"	165	(225)	290	(390)	400	(540)
7/8"	170	(230)	420	(570)	650	(880)
1"	225	(300)	630	(850)	970	(1310)

### **Bolt Torque for Metric bolts \***

"A"	CLASS 8.8		CLASS 9.8		CLASS 10.9	
	lb-ft	(N.m)	lb-ft	(N.m)	lb-ft	(N.m)
6	9	(13)	10	(14)	13	(17)
7	15	(21)	18	(24)	21	(29)
8	23	(31)	25	(34)	31	(42)
10	45	(61)	50	(68)	61	(83)
12	78	(106)	88	(118)	106	(144)
14	125	(169)	140	(189)	170	(230)
16	194	(263)	216	(293)	263	(357)
18	268	(363)	--	--	364	(493)
20	378	(513)	--	--	515	(689)
22	516	(699)	--	--	702	(952)
24	654	(886)	--	--	890	(1206)

## 6052 21K Upgrade Kit Assembly Instructions

1. Loosely assemble complete fifth wheel hitch assembly and attach the 21K upgrade bracket that has the decal so it is facing towards tailgate of tow vehicle. Attach using the rear roller bolts and nuts and both the front and rear spacer bolts and nuts. Use the extra  $\frac{1}{2}$ " bolts, nuts, and washers supplied with kit for the front bracket.
2. Attach the other bracket to rear of hitch assembly as shown in drawing.
3. Tighten the top roller bolts only to snug. DO NOT OVER TIGHTEN. The bottom bolts can be tightened to 80-90 lbs.

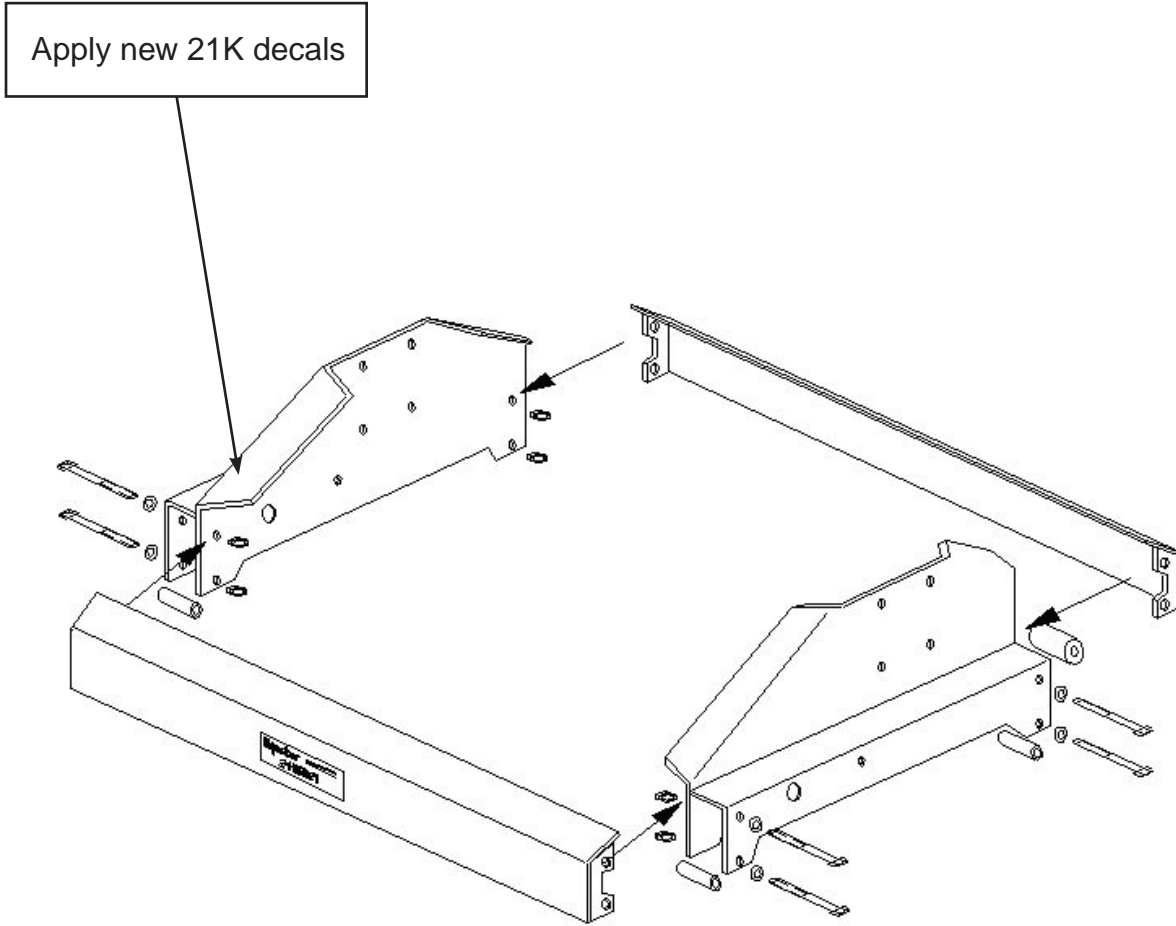

## 6052 Parts Breakdown

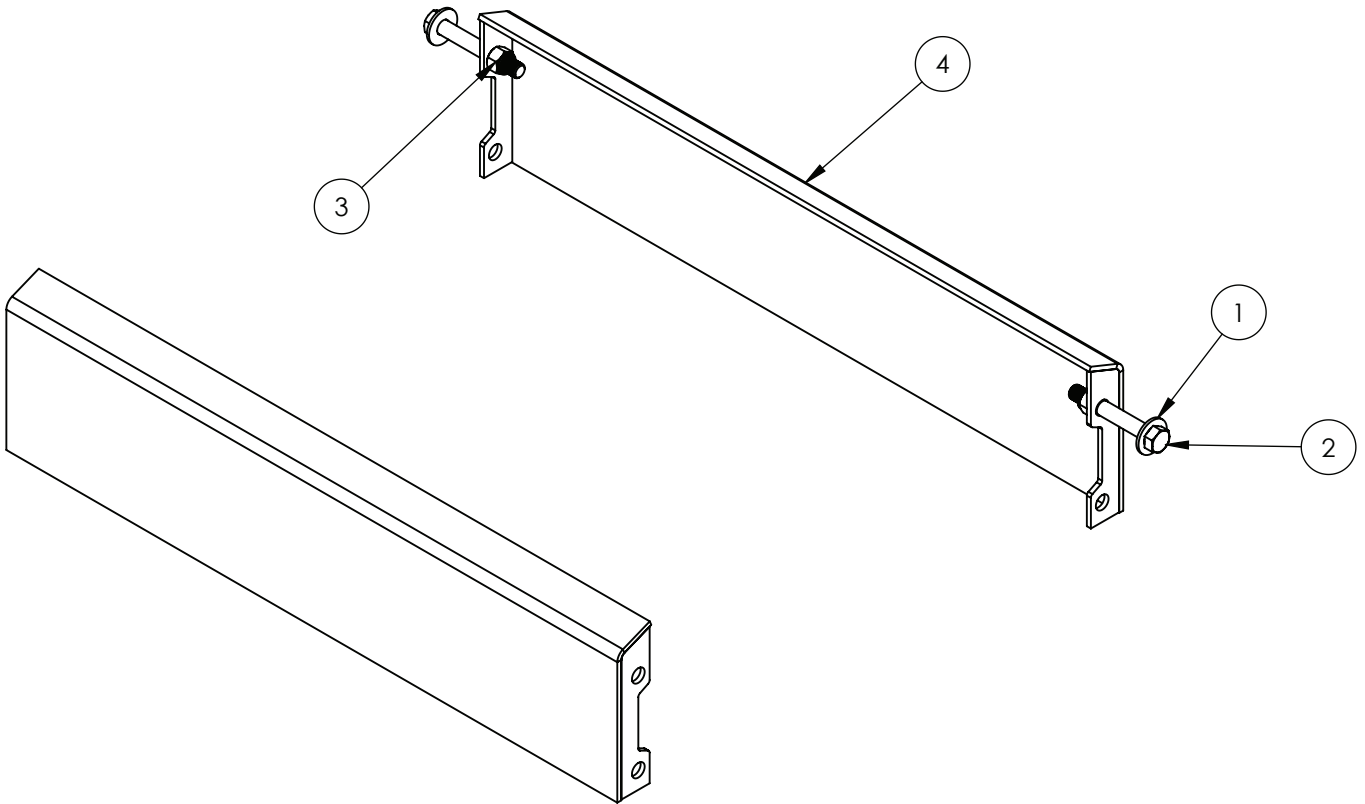

### 6052 Parts Breakdown

ITEM	PART #	QTY	DESCRIPTION
1	00085	2	.50 FLAT WASHER
2	01897	2	BOLT, .50NC X 3.50 HEX HEAD
3	02178	2	NUT, .50NC LOCK, NY. INSERT
4	14534-76	2	ULS 21K BRACE

Please order replacement parts by PART NO. and DESCRIPTION.