

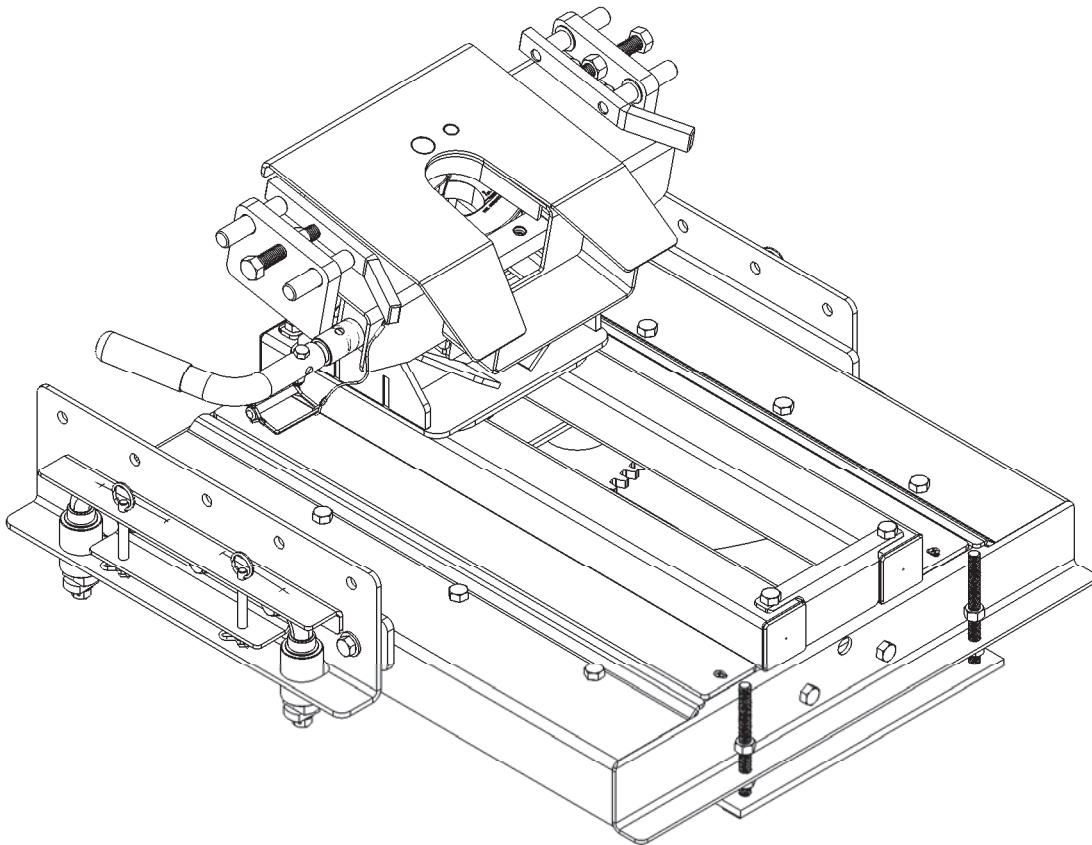

Demco

5th Wheel Side Rail Assemblies

6033 AS REESE Style UMS



READ *complete manual CAREFULLY
BEFORE attempting operation.*

Doing Our Best to Provide You the Best

MANUAL
OPERATORS



Torque Specifications

BOLT TORQUE DATA FOR STANDARD NUTS, BOLTS, AND CAPSCREWS.

Tighten all bolts to torques specified in chart unless otherwise noted. Check tightness of bolts periodically, using bolt chart as guide. Replace hardware with same grade bolt.

NOTE: Unless otherwise specified, high-strength Grade 5 hex bolts are used throughout assembly of equipment.

Torque figures indicated are valid for non-greased or non-oiled threads and heads unless otherwise specified. Therefore, do not grease or oil bolts or capscrews unless otherwise specified in this manual. When using locking elements, increase torque values by 5%.

* GRADE or CLASS value for bolts and capscrews are identified by their head markings.

Bolt Torque for Standard bolts *

"A"	GRADE 2		GRADE 5		GRADE 8	
	lb-ft	(N.m)	lb-ft	(N.m)	lb-ft	(N.m)
1/4"	6	(8)	9	(12)	12	(16)
5/16"	10	(13)	18	(25)	25	(35)
3/8"	20	(27)	30	(40)	45	(60)
7/16"	30	(40)	50	(70)	80	(110)
1/2"	45	(60)	75	(100)	115	(155)
9/16"	70	(95)	115	(155)	165	(220)
5/8"	95	(130)	150	(200)	225	(300)
3/4"	165	(225)	290	(390)	400	(540)
7/8"	170	(230)	420	(570)	650	(880)
1"	225	(300)	630	(850)	970	(1310)

Bolt Torque for Metric bolts *

"A"	CLASS 8.8		CLASS 9.8		CLASS 10.9	
	lb-ft	(N.m)	lb-ft	(N.m)	lb-ft	(N.m)
6	9	(13)	10	(14)	13	(17)
7	15	(21)	18	(24)	21	(29)
8	23	(31)	25	(34)	31	(42)
10	45	(61)	50	(68)	61	(83)
12	78	(106)	88	(118)	106	(144)
14	125	(169)	140	(189)	170	(230)
16	194	(263)	216	(293)	263	(357)
18	268	(363)	--	--	364	(493)
20	378	(513)	--	--	515	(689)
22	516	(699)	--	--	702	(952)
24	654	(886)	--	--	890	(1206)

6033 Side Rail Assembly Instructions

1. Prefit the side rails in the pucks of the truck and make sure the handles will lock into place. If handles are too tight or don't lock into place, remove bottom nut #1 from parts breakdown and take handle out of bushing. There will be a couple of washers #12 between handle and bushing that can be removed to adjust the tightness of the handles in the trucks pucks. Reinstall handles and check for fit.
2. Loosely bolt the main Autoslide assembly to the side rails with spacer plates using the 1/2" x 1 3/4" bolts, flat washers, and lock nuts provided in the side rail bolt package at the predetermined height using the bolt pattern guide in below. **NOTE:** On highest setting, use 6 bolts. The 4 along the top row are to fasten to hitch assembly and the bottom 2 are to fasten the side rail brace to side rail to retain locking pins. (1/4" & 3/8" thick spacers are supplied for adjusting the hitch mount width with the bed pockets. You may mix and match the different shim thicknesses for fine tuning the fit).
3. Tighten all bolts.
4. Unlock locking pins and insert the hitch assembly into the base rails and test for fit. If the pins are too narrow to drop in, follow the alignment procedure on page 3.
5. Proceed to base rail install procedure as provided in the base rail installation kit.

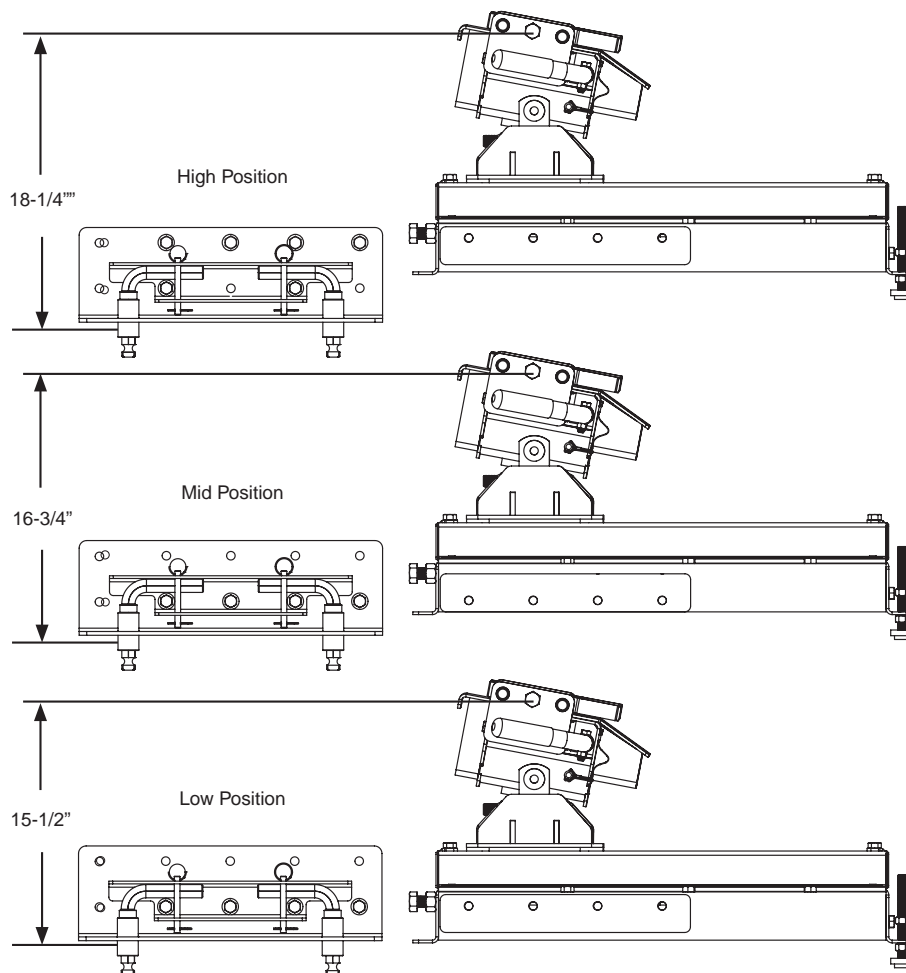

IMPORTANT NOTE: Incorrect mounting of the side plates to the main body will result in the incorrect position of the hitch for towing and will not allow the hitch to travel back to its full 14" ability.

IMPORTANT NOTE: Apply a little grease or lubricant to the part of the pins that insert into the base rails to help maintain smooth operation and rotation of pins and to protect from the elements. Turn the pins occasionally to prevent them from seizing.

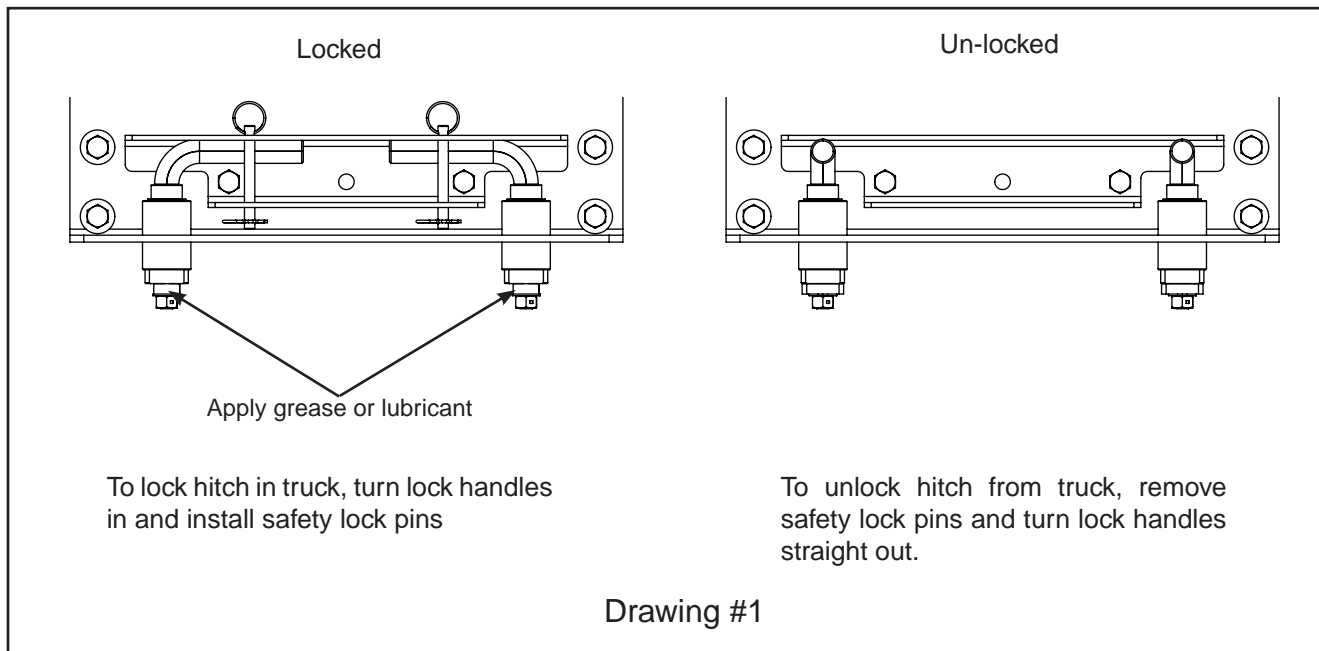

6033 Parts Breakdown

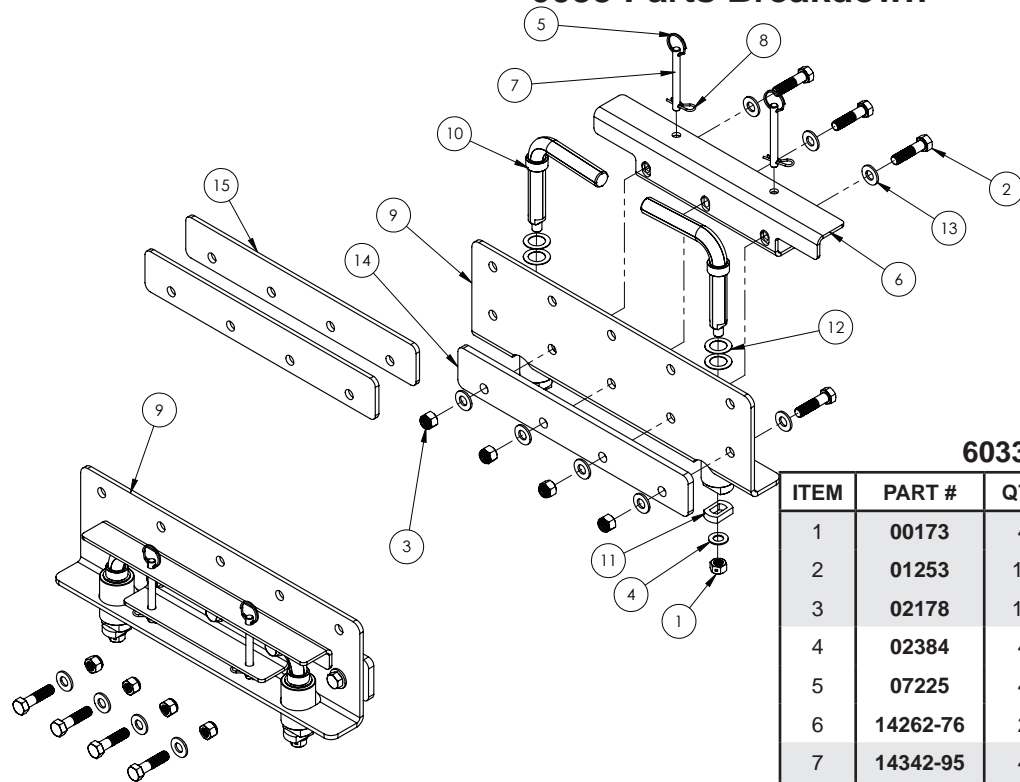

6033 Parts Breakdown

ITEM	PART #	QTY	DESCRIPTION
1	00173	4	NUT, HEX, .50NC CENTER PUNCH
2	01253	12	BOLT, .50 NC X 2.00 GR.5 HEX
3	02178	12	NUT, .50NC LOCK, NY. INSERT
4	02384	4	.50 X 14GA MACHINE WASHER
5	07225	4	SPLIT RING
6	14262-76	2	UMS SIDE RAIL BRACE
7	14342-95	4	CLEVIS SAFETY PIN
8	14350	4	HAIR PIN, .093 WIRE X 1.63 OL
9	14411-76	2	UMAS SIDE RAIL, REESE
10	14412-95	4	UMS LOCK PIN ASSEMBLY, REESE
11	14413-95	4	LOCKING TAB
12	14423	8	WASHER SHIM .875 ID X .030 THK
13	14488	20	.50 FLAT WASHER NARROW RIM
14	14763-76	2	.375 UMS AS SPACER
15	14959-76	2	.25 AS SPACER

Demco

Please order replacement parts by PART NO. and DESCRIPTION.

Rely only on high-grade trailer hitches & towing offered on our virtual shelves.