



**PLEASE INSPECT YOUR PRODUCT FOR DAMAGE  
BEFORE PROCEEDING TO INSTALLATION.**



Thank you for choosing Dee Zee to add function and accessorize your vehicle. Dee Zee has been a staple brand in the truck accessory market since 1977 and we hold a reputation of quality manufacturing based in America's Heartland. Our products are born through careful engineering and backed by industry leading warranty programs. We appreciate the opportunity to serve you and your vehicle!

**Review the instruction pages in their entirety to prepare the required tools**

**Warning:** Please check for wiring or other obstructions before drilling any holes in the vehicle. If it is necessary to drill any holes, Dee Zee recommends putting a sealant or rust inhibitory around all holes drilled into the body of the vehicle.

It is the sole responsibility of the vehicle owner to check for tire clearance. It is unlawful and dangerous to ride on any external vehicle step while the vehicle is in motion.



**Cleaning:** To be entitled to all warranty rights offered with the product, Dee Zee steps need to be cleaned regularly with a mild detergent. Do NOT use abrasive cleaners. For stainless steel products, the application of a high grade automotive wax is recommended.

# NXT RUNNING BOARD INSTALLATION INSTRUCTION

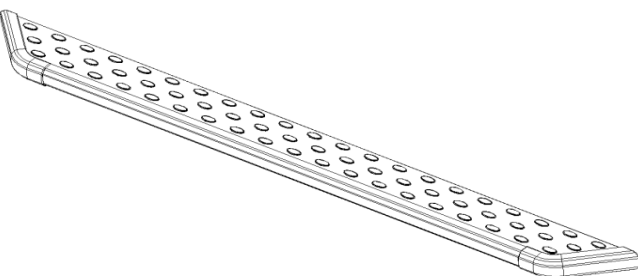
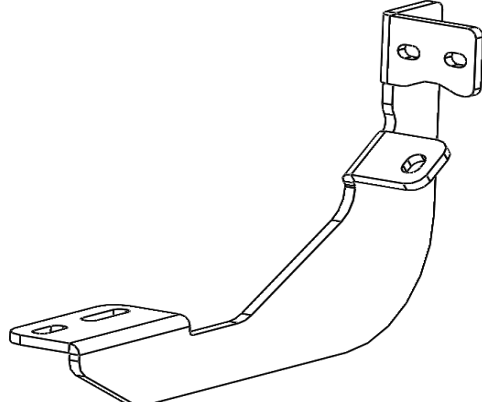
## DZ 16355 NISSAN TITAN 12016-CURRENT

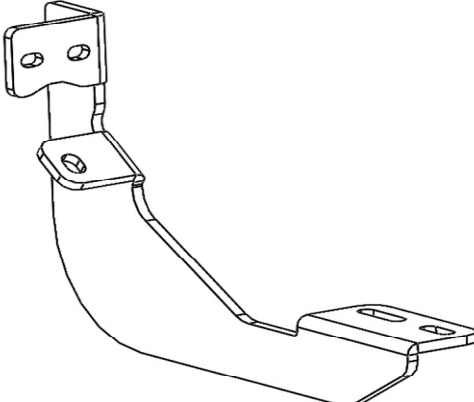
<div style="display: flex; justify-content: space-between;"> <span style="font-size: 24px; font-weight: bold;">A</span> <span>SIDE STEP TUBE</span> </div>  <p style="margin-top: 20px;">*** BOARD SOLD SEPARATELY</p>	<div style="display: flex; justify-content: space-between;"> <span style="font-size: 24px; font-weight: bold;">B</span> <span>BRACKET LEFT HAND</span> </div>  <p style="text-align: right; margin-top: 10px;"><b>X2</b> B 2401LP <b>X3</b></p>
---	---

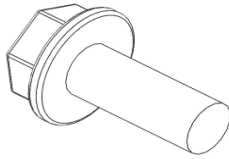
<div style="display: flex; justify-content: space-between;"> <span style="font-size: 24px; font-weight: bold;">C</span> <span>BRACKET RIGHT HAND</span> </div>  <p style="margin-top: 10px;"><b>B 2401RP</b> <b>X3</b></p>	
--	--

<div style="display: flex; justify-content: space-between;"> <span style="font-size: 24px; font-weight: bold;">D</span> <span>8mm X 25mm FLANGE HEAD BOLT</span> </div>  <p style="margin-top: 10px;"><b>PN 525</b> <b>X12</b></p>	<div style="display: flex; justify-content: space-between;"> <span style="font-size: 24px; font-weight: bold;">E</span> <span>8mm FLANGE HEAD NUT</span> </div>  <p style="margin-top: 10px;"><b>PN 526</b> <b>X12</b></p>		
---	---	--	--

--	--	--	--

## TOOLS REQUIRED

WRENCH/RATCHET

13mm

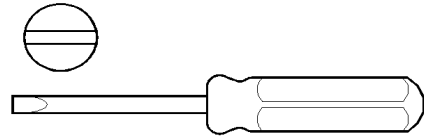
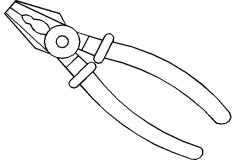

**1**

On the inner rocker panel, remove the 3 plugs from the lower mounting holes.  
The driver's side is shown. The front of the vehicle is to the right in the picture.

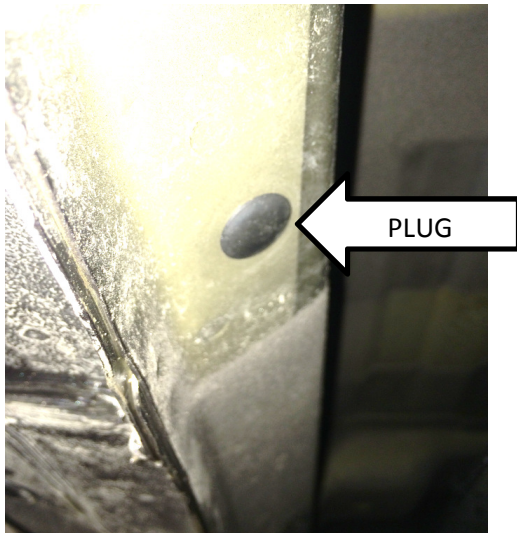
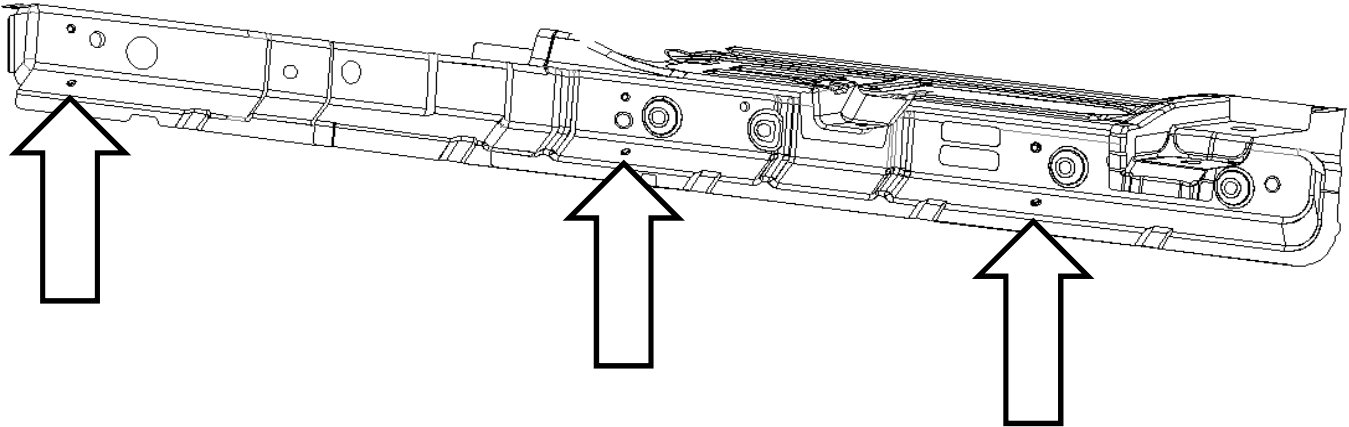

Use a standard screwdriver to lift the edge of the plug and a pair of pliers to pull the plug out.

Discard the plugs.

The regular cab does not have a middle mounting location. Extra brackets and hardware may be discarded.

**2** Attached the mounting brackets [B] to the lower mounting locations where the plug was removed using the 8mm x 25mm bolt [D].

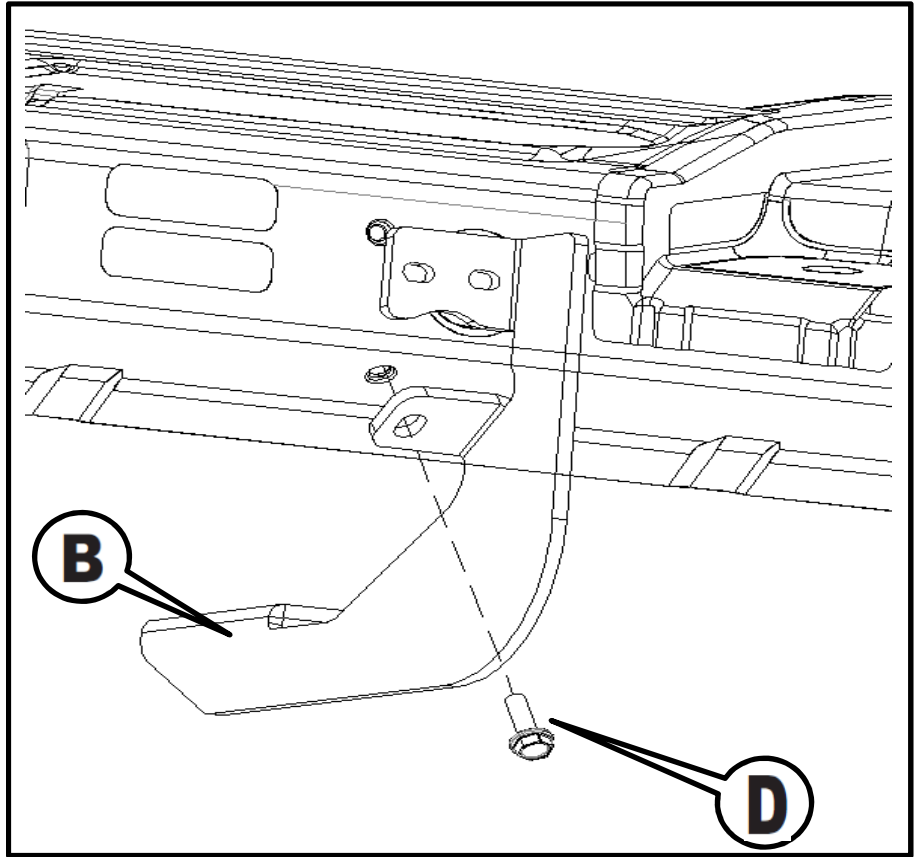

Bracket [C] will be used for the mounting locations on the passenger side.

Do not completely tighten at this time.

Attached the mounting brackets [B] to the upper mounting locations where the plug was removed using the 8mm x 25mm bolt [D].

Depending on the brace location on the vehicle and the cab style of the truck, the upper mounting bolt will be used in one of the two slots. Check for the location of the weld nut in the vehicle and use the appropriate slot.

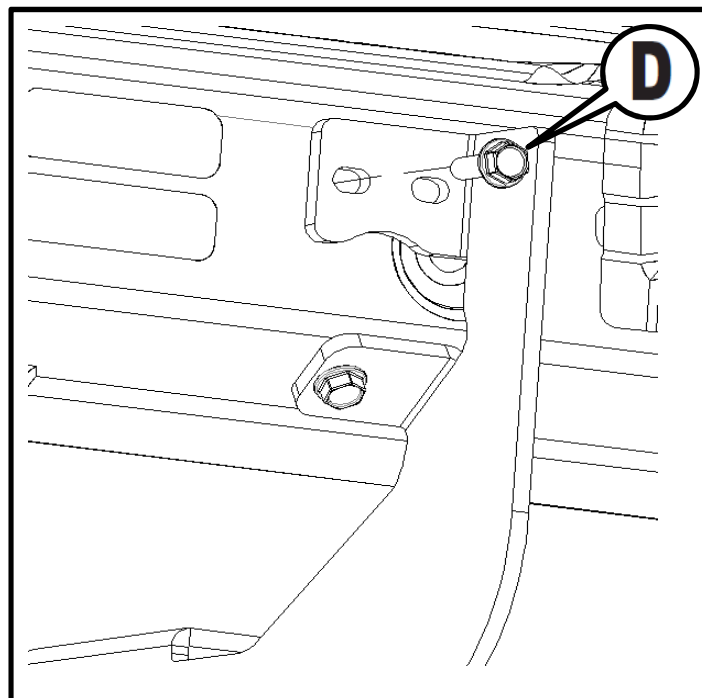

Do not completely tighten at this time.

- 3** Align the bolts in the channels on the underside of the running board with the slots in the mounting braces and loosely attach the board to the brace at each location with the 8mm nuts [E]. Do not completely tighten at this time.

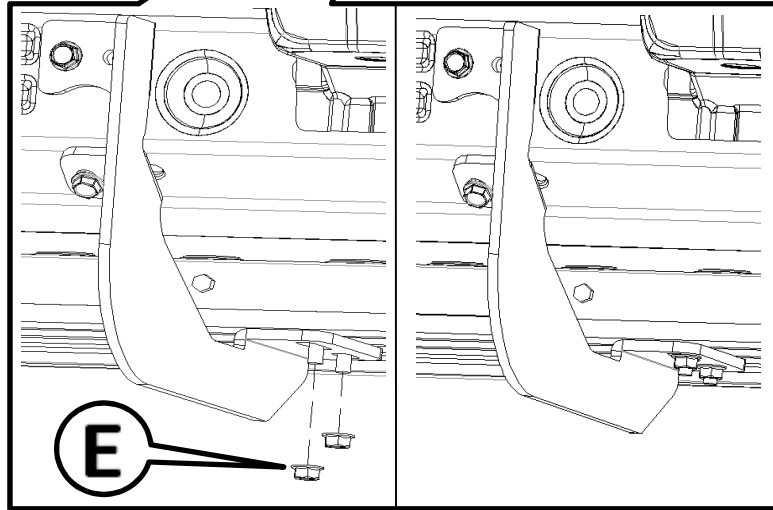
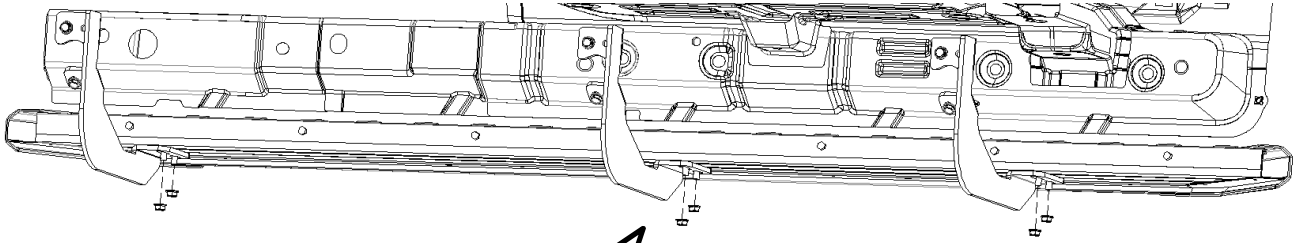

- 4** Using a 13mm socket/wrench, tighten the bolts that attach the brace to the vehicle. Once all of the braces have been tightened, adjust the board front/back and in/out to align it with the vehicle.

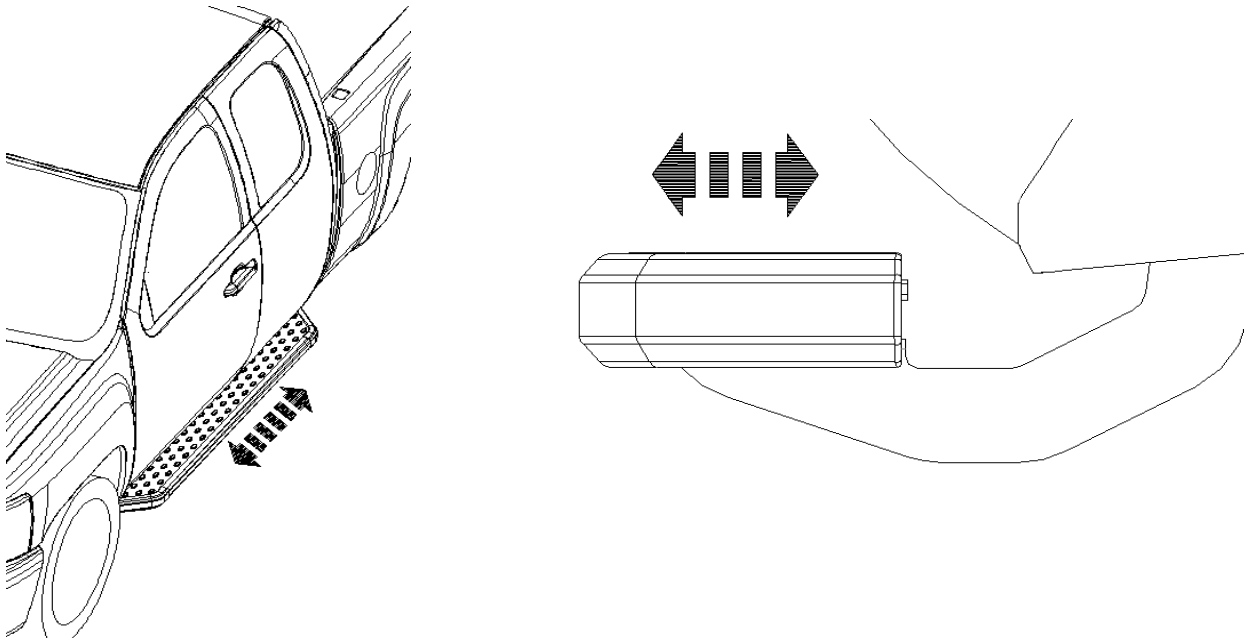

**5**

Once the board location has been set, tighten the nuts holding the board to the braces using a 13mm socket/wrench.

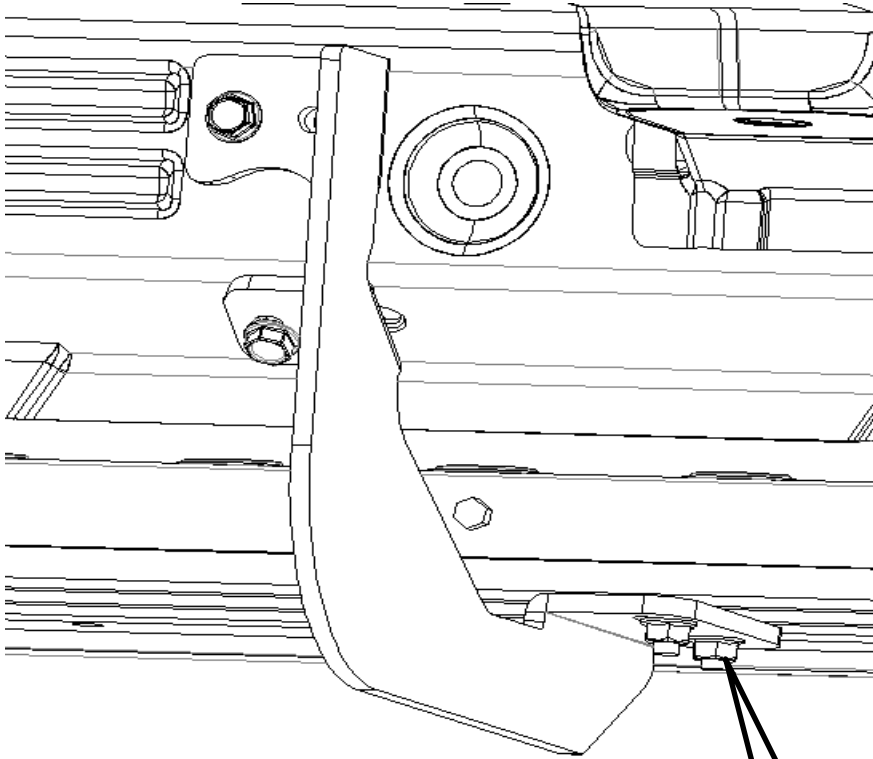

**TIGHTEN**

Make sure all bolts are tightened. Repeat steps for other side.

# 6" OVAL SIDE STEP INSTALLTION DZ 16355 NISSAN TITAN 12016-CURRENT

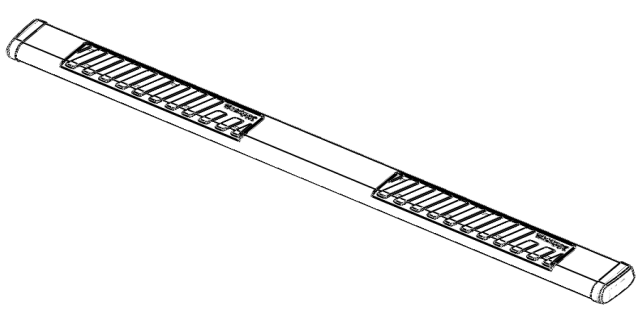
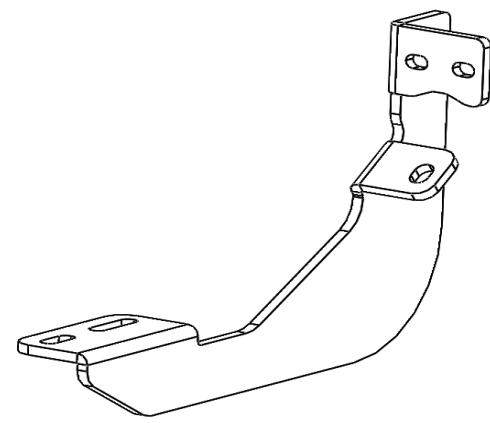
<div style="display: flex; justify-content: space-between;"> <span style="font-size: 24px; font-weight: bold;">A</span> <span>SIDE STEP TUBE</span> </div> <div style="text-align: center; margin-top: 20px;">  </div> <p style="text-align: center; margin-top: 20px;">*** TUBE SOLD SEPARATELY</p>	<div style="display: flex; justify-content: space-between;"> <span style="font-size: 24px; font-weight: bold;">B</span> <span>BRACKET LEFT HAND</span> </div> <div style="text-align: center; margin-top: 20px;">  </div> <div style="display: flex; justify-content: space-between; margin-top: 20px;"> <span>X2</span> <span>B 2401LP</span> <span>X3</span> </div>
---	---

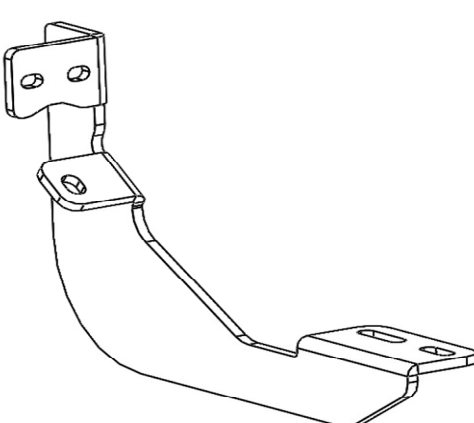
<div style="display: flex; justify-content: space-between;"> <span style="font-size: 24px; font-weight: bold;">C</span> <span>BRACKET RIGHT HAND</span> </div> <div style="text-align: center; margin-top: 20px;">  </div> <div style="display: flex; justify-content: space-between; margin-top: 20px;"> <span>B 2401RP</span> <span>X3</span> </div>	
--	--

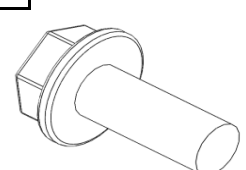
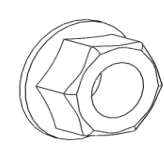
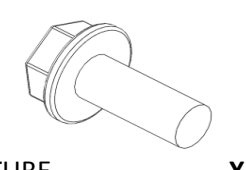
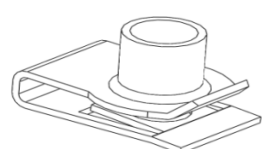
<div style="display: flex; justify-content: space-between;"> <span style="font-size: 24px; font-weight: bold;">D</span> <span>8mm X 25mm FLANGE HEAD BOLT</span> </div> <div style="text-align: center; margin-top: 20px;">  </div> <div style="display: flex; justify-content: space-between; margin-top: 20px;"> <span>PN 525</span> <span>X12</span> </div>	<div style="display: flex; justify-content: space-between;"> <span style="font-size: 24px; font-weight: bold;">E</span> <span>8mm FLANGE HEAD NUT</span> </div> <div style="text-align: center; margin-top: 20px;">  </div> <div style="display: flex; justify-content: space-between; margin-top: 20px;"> <span>PN 526</span> <span>X12</span> </div>	<div style="display: flex; justify-content: space-between;"> <span style="font-size: 24px; font-weight: bold;">F</span> <span>8mm X 20mm FLANGE HEAD BOLT</span> </div> <div style="text-align: center; margin-top: 20px;">  </div> <div style="display: flex; justify-content: space-between; margin-top: 20px;"> <span>FROM TUBE BOLT PACK</span> <span>X8</span> </div>	<div style="display: flex; justify-content: space-between;"> <span style="font-size: 24px; font-weight: bold;">G</span> <span>8mm U-NUT</span> </div> <div style="text-align: center; margin-top: 20px;">  </div> <div style="display: flex; justify-content: space-between; margin-top: 20px;"> <span>FROM TUBE BOLT PACK</span> <span>X8</span> </div>
---	---	--	---

--	--	--	--



## TOOLS REQUIRED

WRENCH/RATCHET

13mm

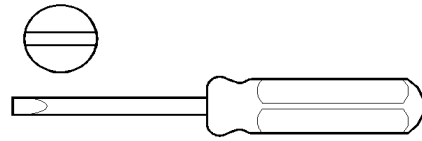
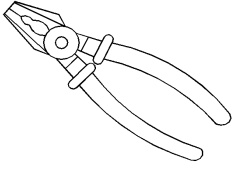

**1**

On the inner rocker panel, remove the 3 plugs from the lower mounting holes.  
The driver's side is shown. The front of the vehicle is to the right in the picture.

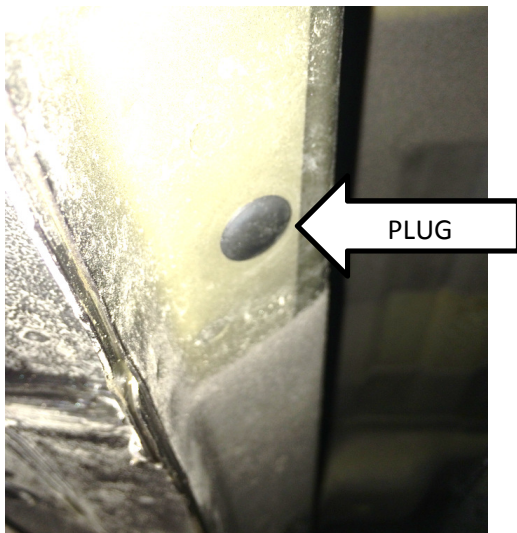
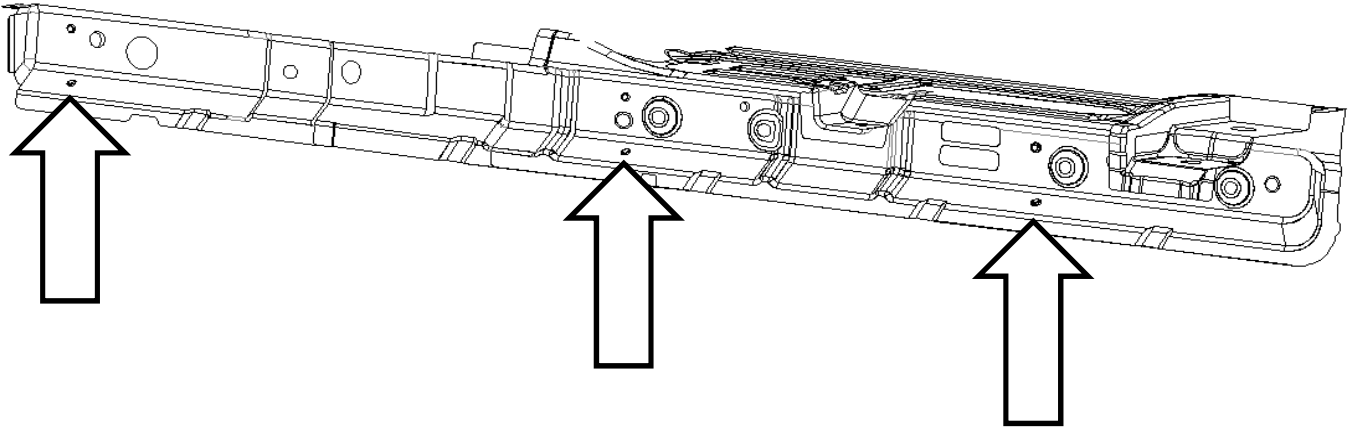

Use a standard screwdriver to lift the edge of the plug and a pair of pliers to pull the plug out.

Discard the plugs.

The regular cab does not have a middle mounting location. Extra brackets and hardware may be discarded.

**2** Attached the mounting brackets [B] to the lower mounting locations where the plug was removed using the 8mm x 25mm bolt [D].

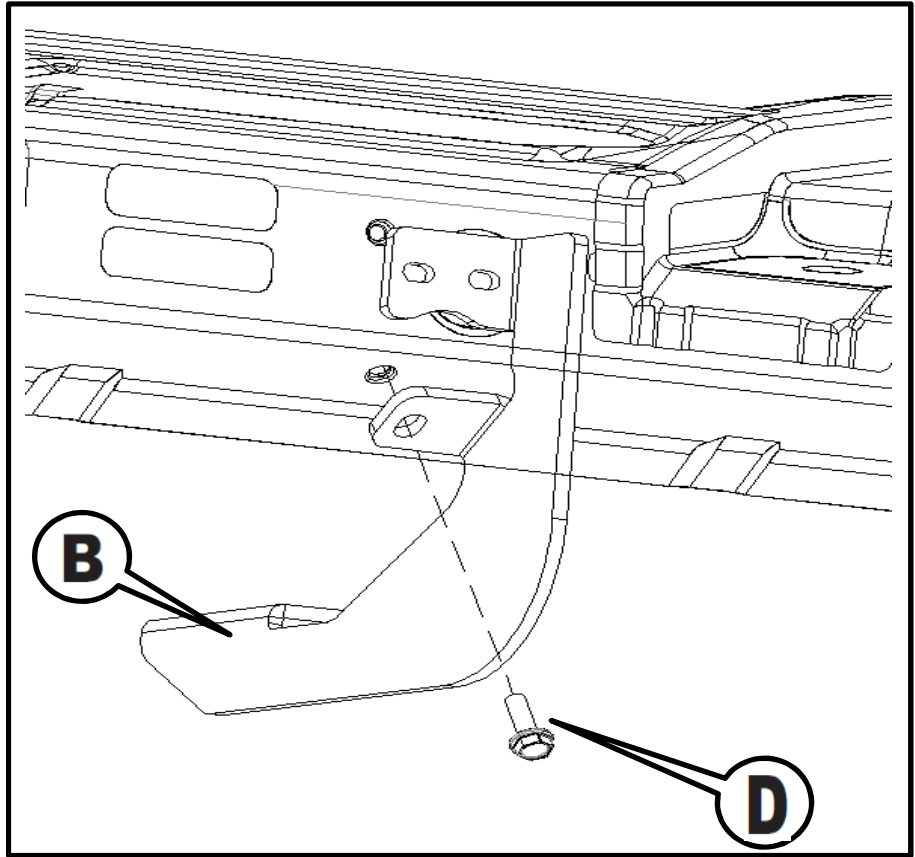

Bracket [C] will be used for the mounting locations on the passenger side.

Do not completely tighten at this time.

Attached the mounting brackets [B] to the upper mounting locations where the plug was removed using the 8mm x 25mm bolt [D].

Depending on the brace location on the vehicle and the cab style of the truck, the upper mounting bolt will be used in one of the two slots. Check for the location of the weld nut in the vehicle and use the appropriate slot.

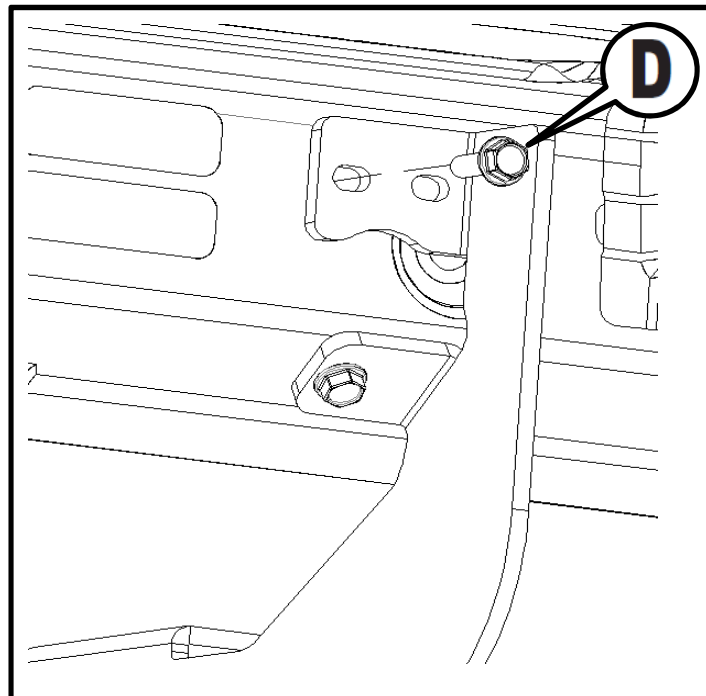

Tighten brace bolts with a 13mm socket / wrench.

- 3** Once the brackets are in place, set the tube on the braces and adjust as necessary front to back. Look under the tube to determine which sets of slots will be used to attach the tube to the braces. Depending on your cab style, the image may appear different than yours, but the install is the same.

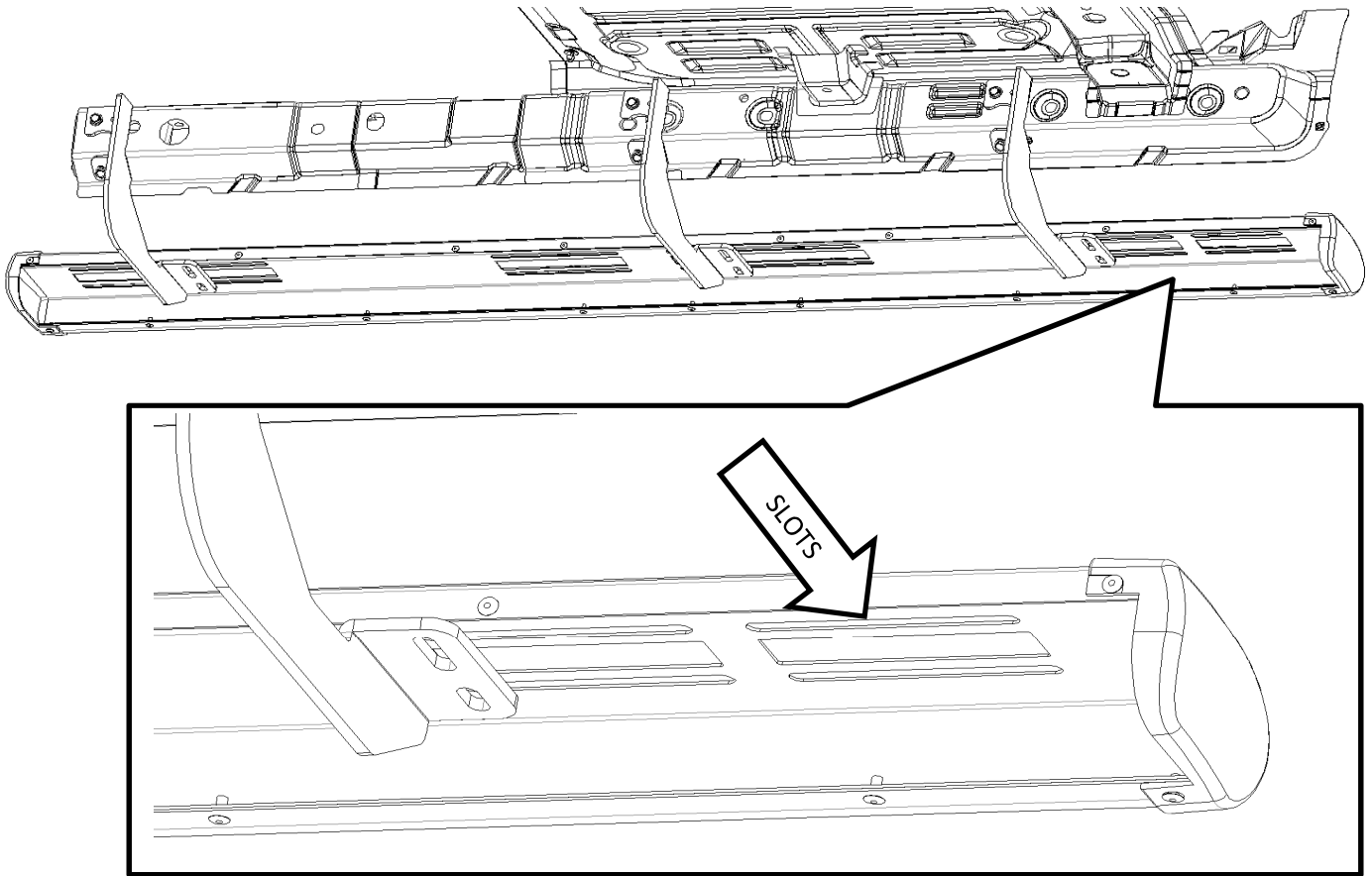

- 4** Remove the tube and install the 8mm U-nuts [G] that were supplied with the tubes into the slots identified in the previous step. Use 2 U-nuts per brace location.

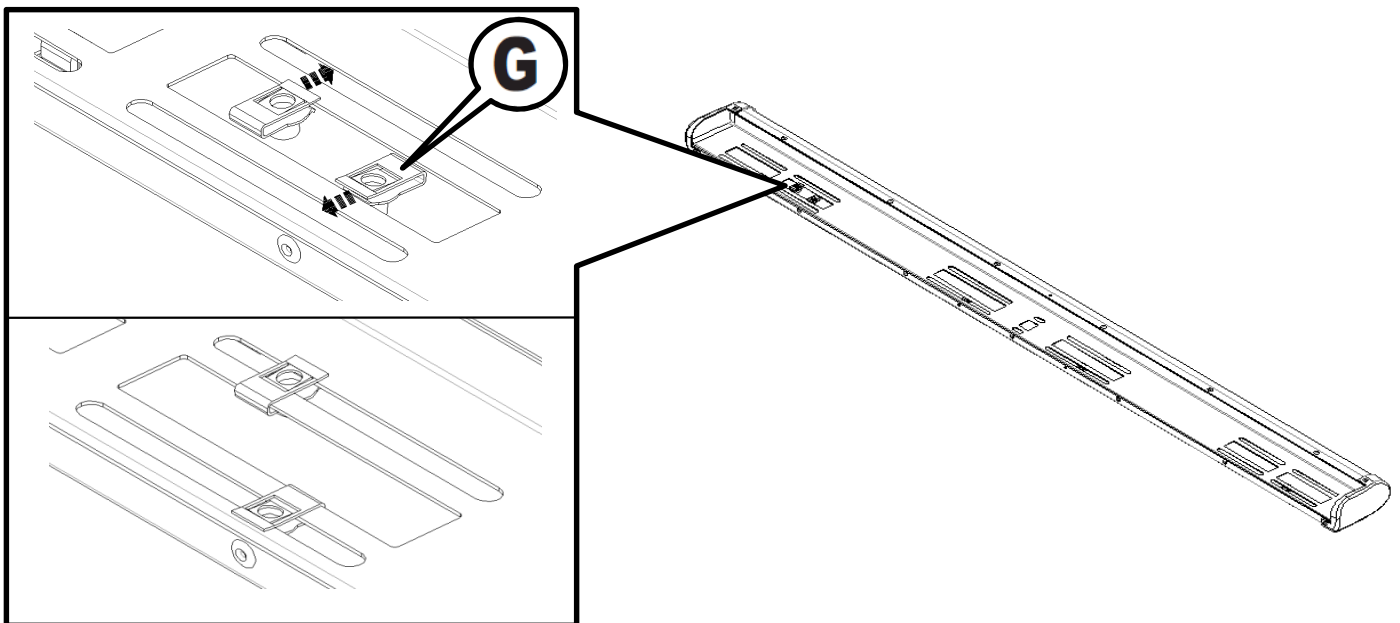

**5** Set the tube back on the brackets and slide the U-nuts in the tube slots so that they align with the mounting slots in the braces. Repeat at all mounting locations.

Attach the tube to the braces using the 8mm x 20mm bolts [F] that were supplied with the tube step. Tighten bolts with a 13mm wrench or socket. Repeat at all mounting locations.

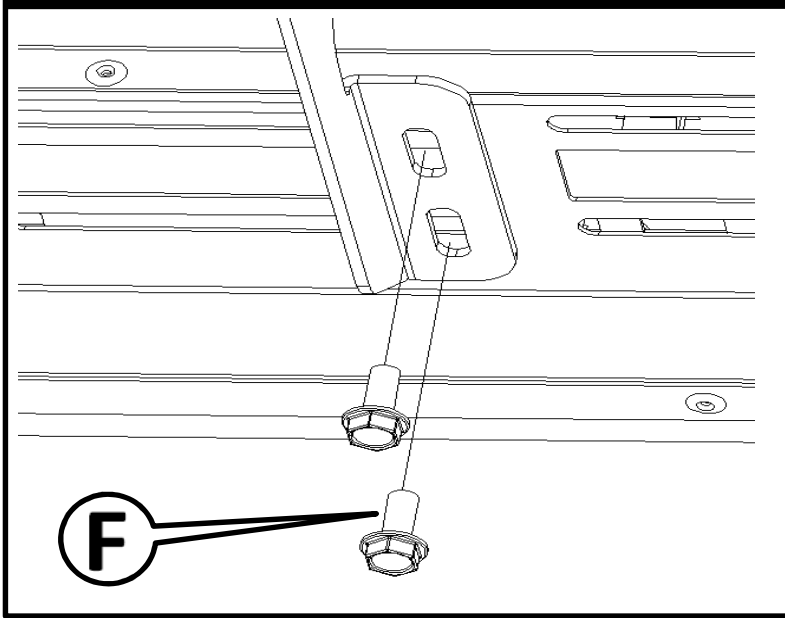
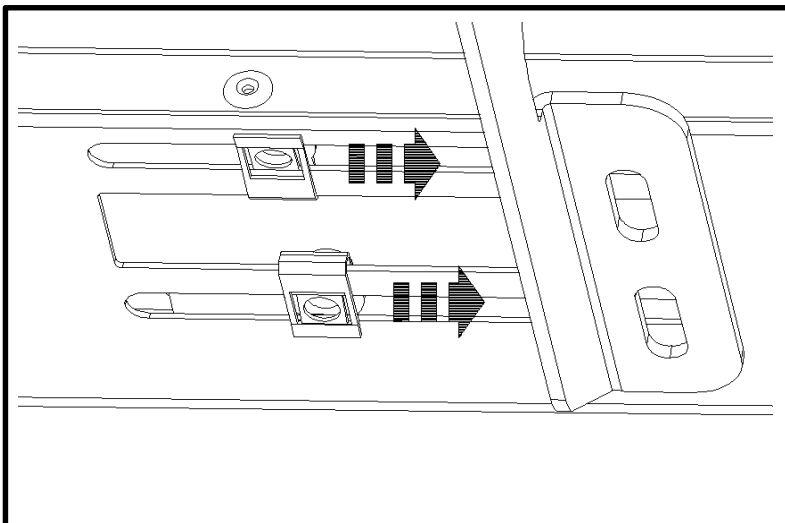
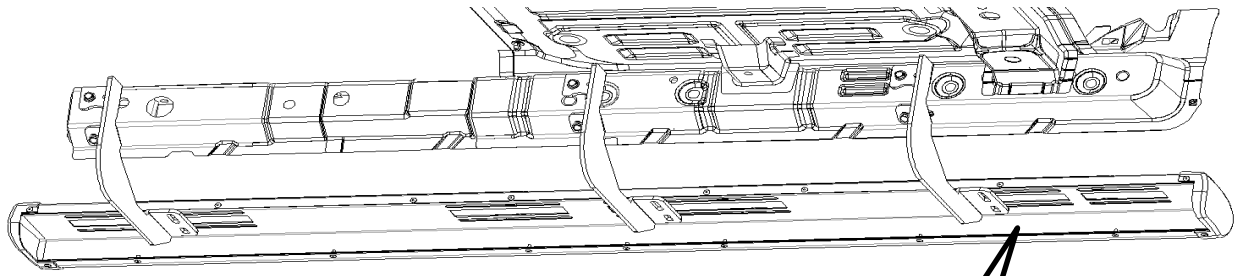

Item E will not be used for the tube installation. The parts can be discarded. Make sure all bolts are tightened. Repeat steps for other side.