



Dee Zee Running Board Installation Instructions

Congratulations on your purchase of a quality Dee Zee product. Dee Zee is recognized as having the highest quality running boards and accessories on the market today. We have earned this reputation by offering our customers a product they can be proud to place on their vehicles. Dee Zee meets all the criteria of manufacturing a custom-fit product which guarantees it to be the easiest product to install.

Note: Please take time to read all of the instructions before beginning this installation.

Warning! Please check for wiring or other obstructions before drilling any holes into the vehicle. If it is necessary to drill any holes into the vehicle, Dee Zee recommends putting a sealant or rust inhibitor around all holes drilled into the body of the vehicle.

Warning! It is the sole responsibility of the vehicle owner to check for tire clearance.

Warning! It is unlawful and dangerous to ride on running boards or side box boards while vehicle is in motion.

Cleaning instructions: To maintain the bright finish of your Dee Zee running boards, clean with a mild detergent and use a high grade automotive type wax. **DO NOT USE ABRASIVE CLEANERS ON THIS PRODUCT!**

Rough Step Running Board Installation Instructions DZ 15328 (2015-Current) Ford Transit Van (Front Only)

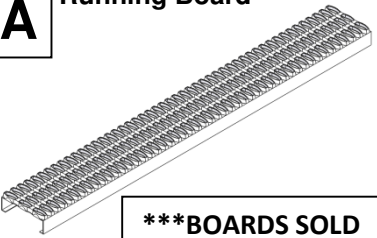
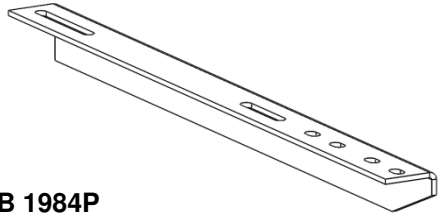
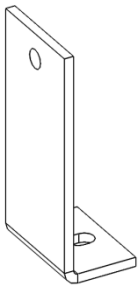
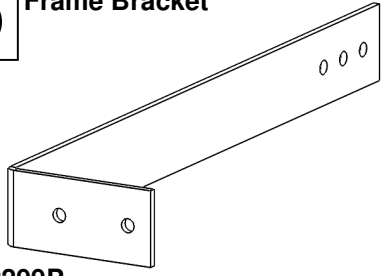
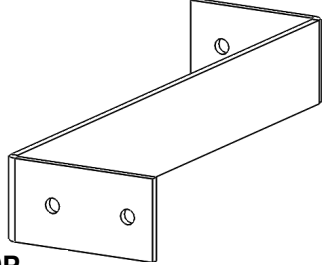
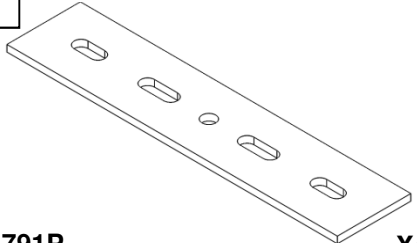
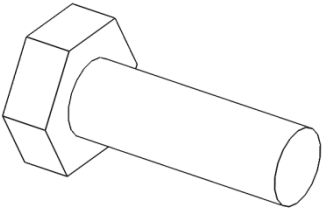
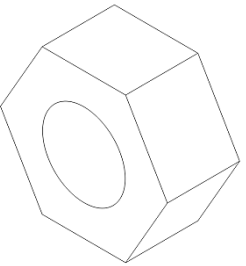
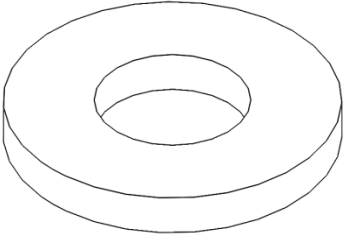
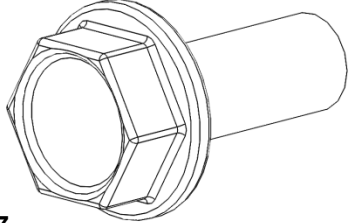
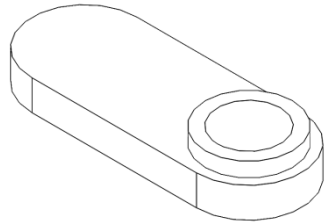
<p>A Running Board</p>  <p>Various</p> <div style="border: 1px solid black; padding: 2px; width: fit-content; margin: 5px auto;"> <p>***BOARDS SOLD SEPERATELY</p> </div>	<p>B Angle Brace</p>  <p>X2 B 1984P</p>	<p>C Rocker Panel Brace</p>  <p>B 2298P</p> <p style="text-align: right;">X4</p>
<p>D Frame Bracket</p>  <p>B 2299P</p>	<p>E Frame Bracket</p>  <p>X2 B 2300P</p>	<p>F Strap Bracket</p>  <p>B 1791P</p> <p style="text-align: right;">X4</p>
<p>G 1/4"-20 X 3/4" Hex Head Bolt</p>  <p>PN 70</p> <p style="text-align: right;">X22</p>	<p>H 1/4"-20 Hex Nut</p>  <p>PN 71</p> <p style="text-align: right;">X22</p>	<p>I 1/4" Washer</p>  <p>PN 72</p> <p style="text-align: right;">X44</p>
<p>J M8-20mm Hex Head Bolt</p>  <p>PN 527</p> <p style="text-align: right;">X2</p>	<p>K 8MM Small Threaded Plate</p>  <p>PN 714</p> <p style="text-align: right;">X1</p>	

Tools Required

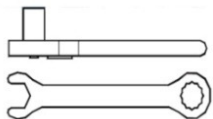

Ratchet / Wrench
9/16", 7/16", 3/8"
13mm

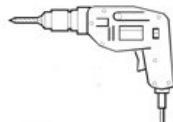

3/16" bit
1/4" bit

Straight Blade
Screwdriver

Level

1

Using a straight blade screw driver, pry the clips at the bottom of the trim open as shown below. Do this for both sides of the vehicle around the front doors only. Do not completely remove the clips.



2

Approximate locations of where to place each brace are shown in the two diagrams below.

Driver's Side

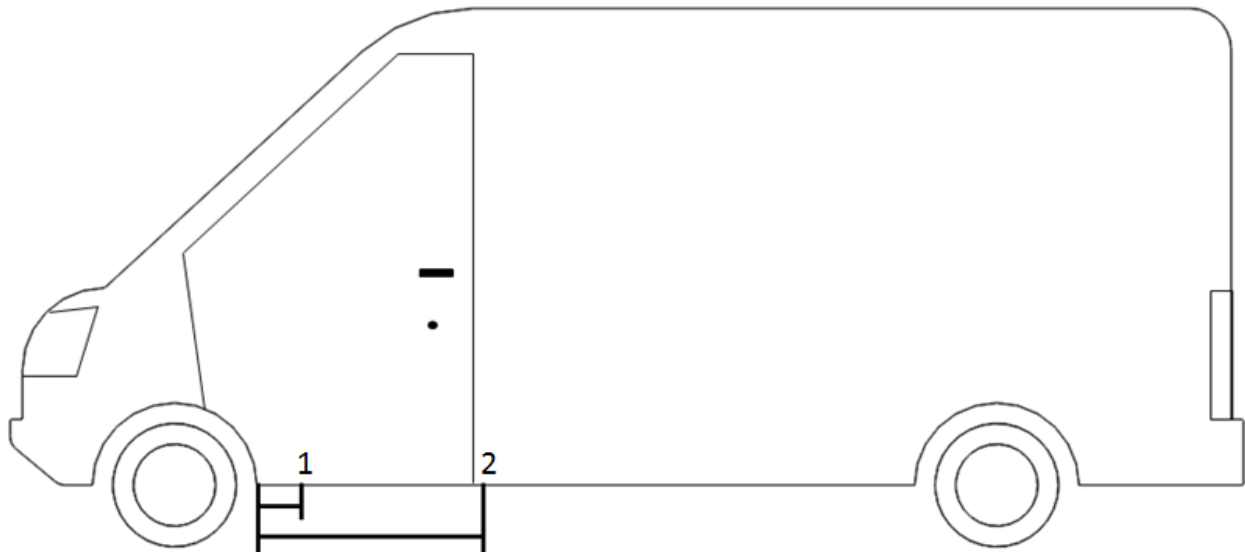

Approximate Distance From Front Wheel Well
(Measured From Inner Well to Front of Angle Brace)

To Location 1 – 8.50 inches

To Location 2 – 31.25 inches

Passenger's Side (Front Only)

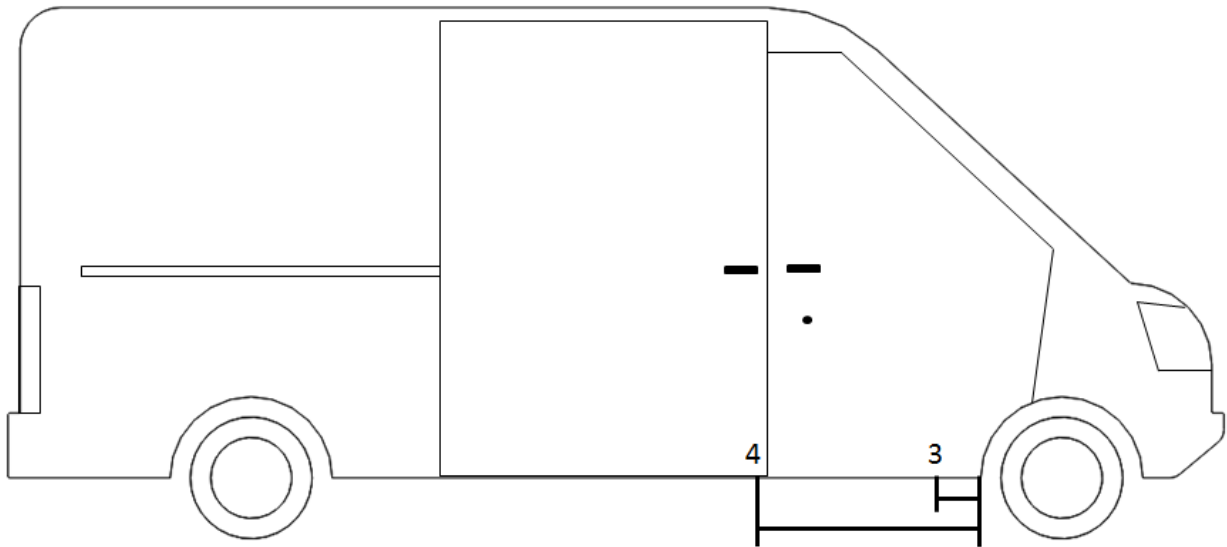

Approximate Distance From Front Wheel Well
(Measured From Inner Well to Front of Angle Brace)
To Location 3 – 12.50 inches
To Location 4 – 35.75 inches

3

Using a Rocker Panel Brace (C) mark where to drill a hole so that the brace can be mounted to the rocker panel. Drill a 1/4" hole at each of these seven locations.

Note: The hole in the Rocker Panel Brace (C) must be completely covered. It is recommended that the Rocker Panel Brace (C) is located as shown in the picture below.

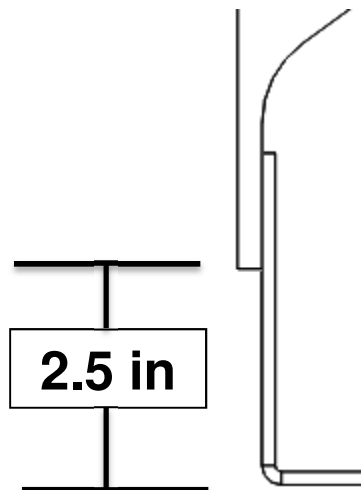

4

Attach the Rocker Panel Brace (C) at each drilled location using one 1/4"-20 X1" Bolt (G), two 1/4" Washer (I), and one 1/4"-20 Nut (H) using a 7/16" Wrench or Ratchet.

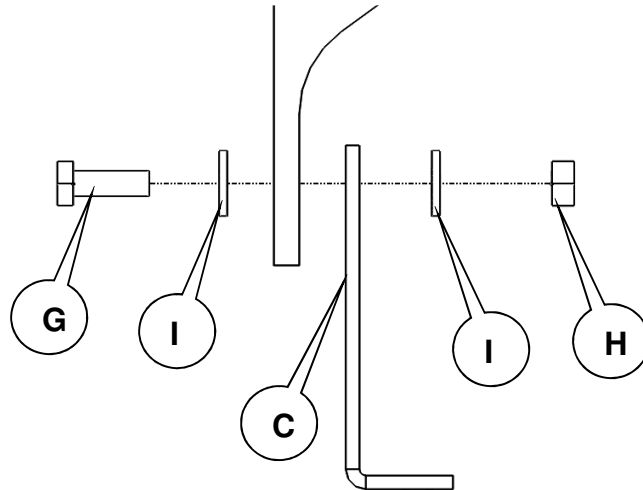
**5**

After each Rocker Panel Brace is installed, attach an Angle Brace (B) at each location using one 1/4"-20 X1" Bolt (G), two 1/4" Washer (I), and one 1/4"-20 Nut (H) using a 7/16" Wrench or Ratchet. Do not completely tighten at this time.

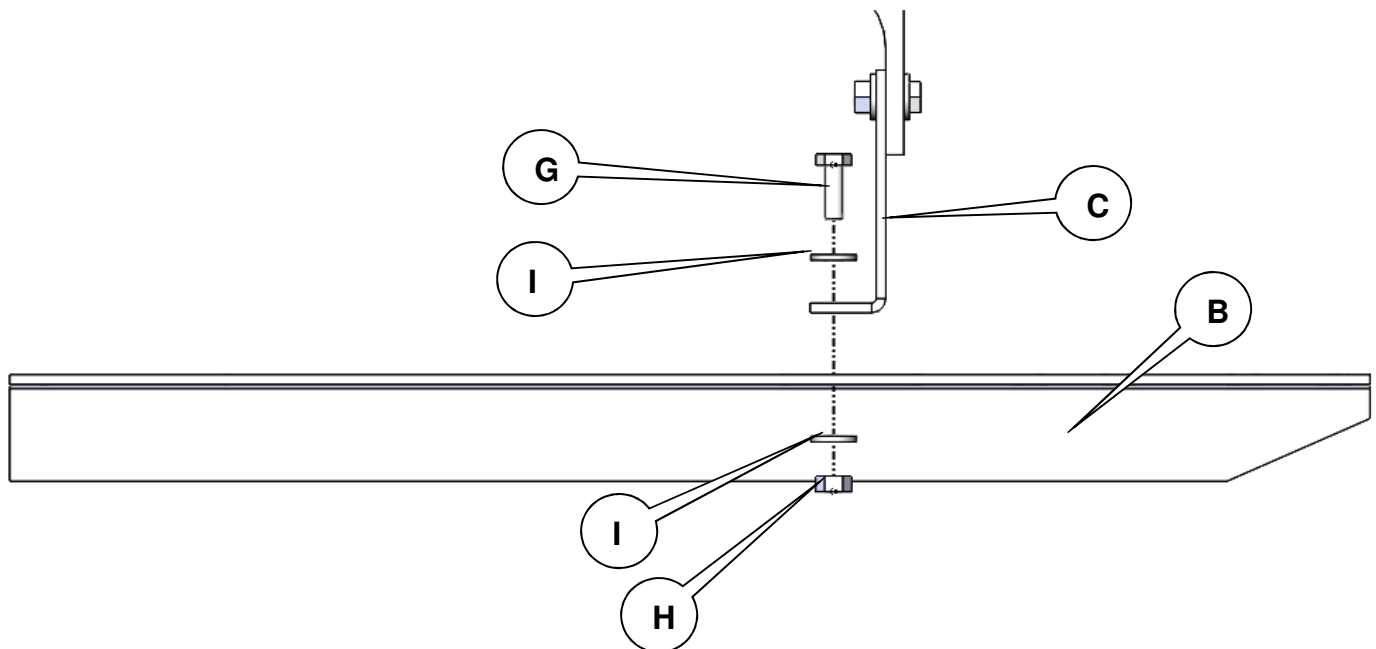

6

At the front Driver's Brace Location (Marked as 1 on the Diagram), use a Frame Bracket (D) and attach to the Angle Brace (B) using one 1/4"-20 X1" Bolt (G), two 1/4" Washer (I), and one 1/4"-20 Nut (H) using a 7/16" Wrench or Ratchet. Do not completely tighten at this time.

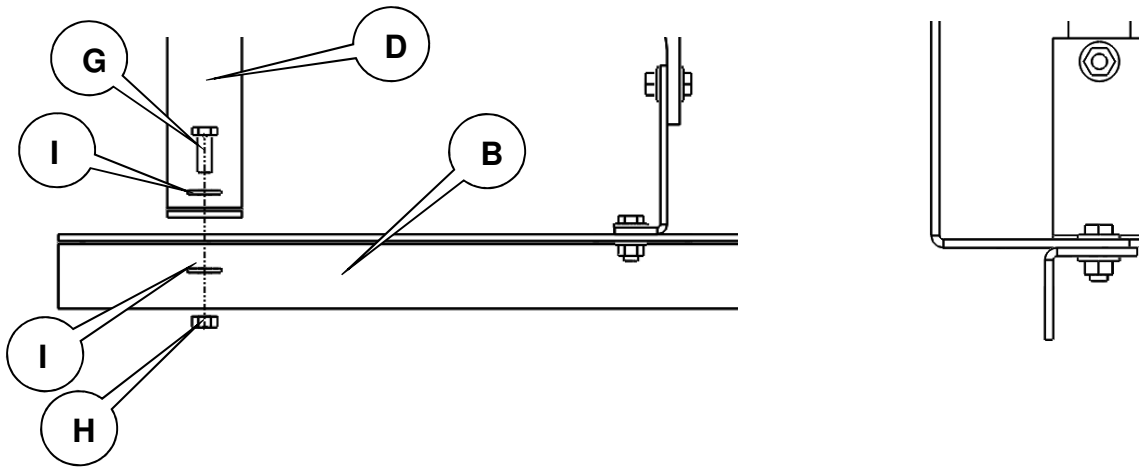
**7**

At the front Driver's Brace Location, attach the top of Frame Bracket (E) to the undercarriage panel as shown below using one 1/4"-20 X1" Bolt (G), two 1/4" Washer (I), and one 1/4"-20 Nut (H) using a 7/16" Wrench or Ratchet. Use a level to make sure that the Angle Brace (C) is parallel to the ground. Do not completely tighten at this time.

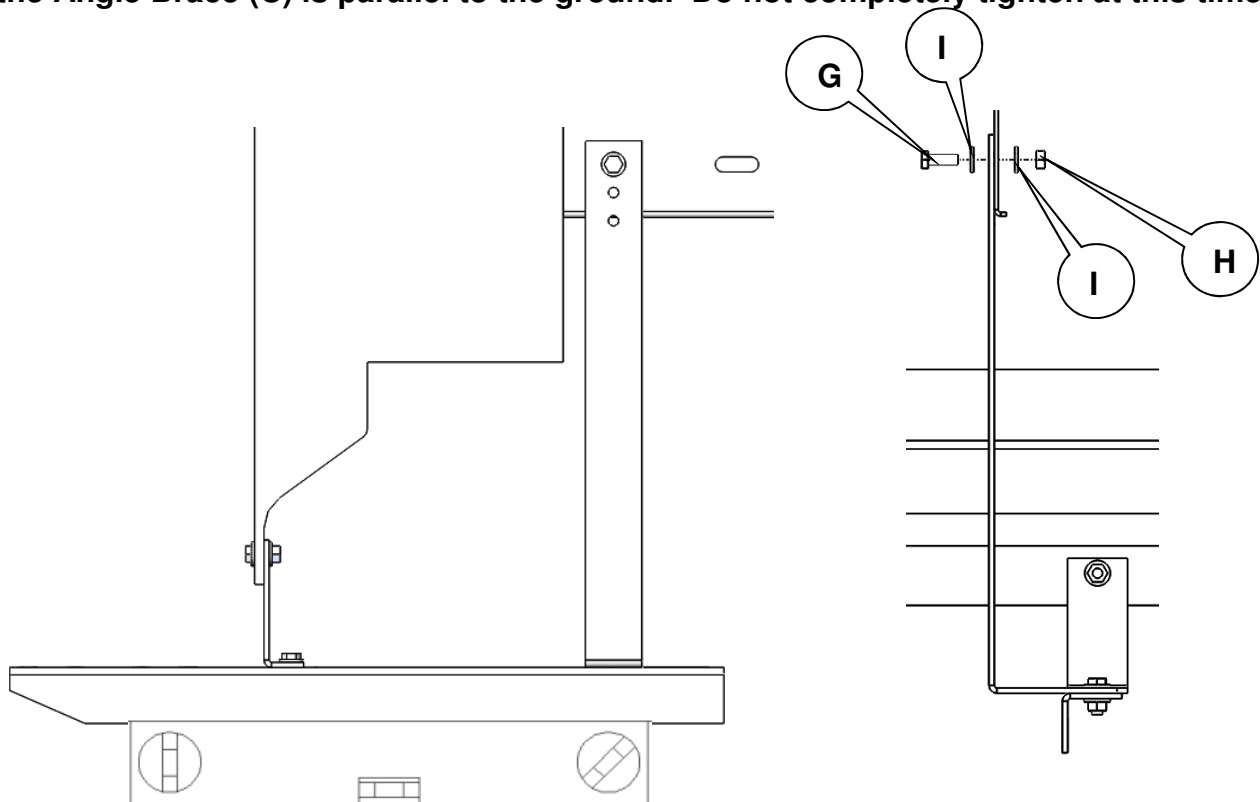

- 8** At the rear Driver's Brace Location (Marked as 2 on the Diagram), use a Frame Bracket (D) and attach to the Angle Brace using one 1/4"-20 X1" Bolt (G), two 1/4" Washer (I), and one 1/4"-20 Nut (H) using a 7/16" Wrench or Ratchet. Do not completely tighten at this time.

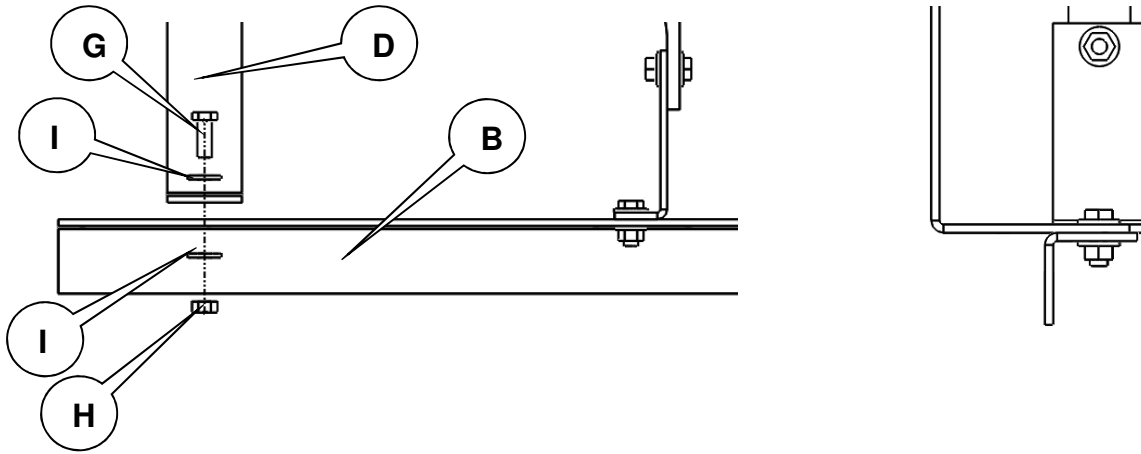

- 9** At the rear Driver's Brace Location, attach the top of Frame Bracket E to the undercarriage panel as shown below using one 1/4"-20 X1" Bolt (G), two 1/4" Washer (I), and one 1/4"-20 Nut (H) using a 7/16" Wrench or Ratchet. Use a level to make sure that the Angle Brace (B) is parallel to the ground. Do not completely tighten at this time. Try to use the existing holes. If the holes don't match up with any of the brace holes, drill a hole using a 1/4" Drill Bit where the hole needs to be. Install the hardware similar to step 8.



- 10** At the front Passenger's Brace Location (Marked as 3 on the Diagram), use a Frame Bracket (E) and attach to the tube running lengthwise of the vehicle using one 8mm Small Threaded Plate (K) and one M8-20mm Hex Head Bolt (J). Insert the M8 bolt (J) through the side with the single hole and attach the 8mm Small Threaded Plate (K) as shown in the picture below. While pulling down on the brace, tighten the M8 bolt (J) using a 13mm Wrench or Ratchet. Do not completely tighten at this time.

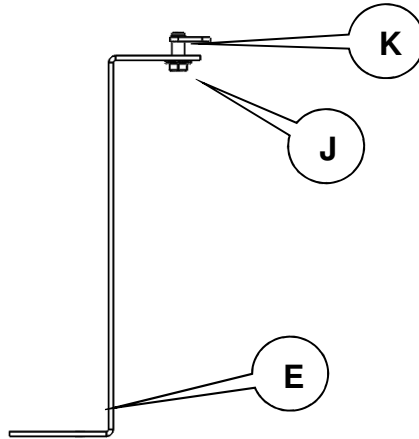

- 11** At the front Passenger's Brace Location, use a Frame Bracket (E) and attach to the Angle Brace (B) using one 1/4"-20 X1" Bolt (G), two 1/4" Washer (I), and one 1/4"-20 Nut (H) using a 7/16" Wrench or Ratchet. Use a level to make sure that the Angle Brace (B) is parallel to the ground. Do not completely tighten at this time.

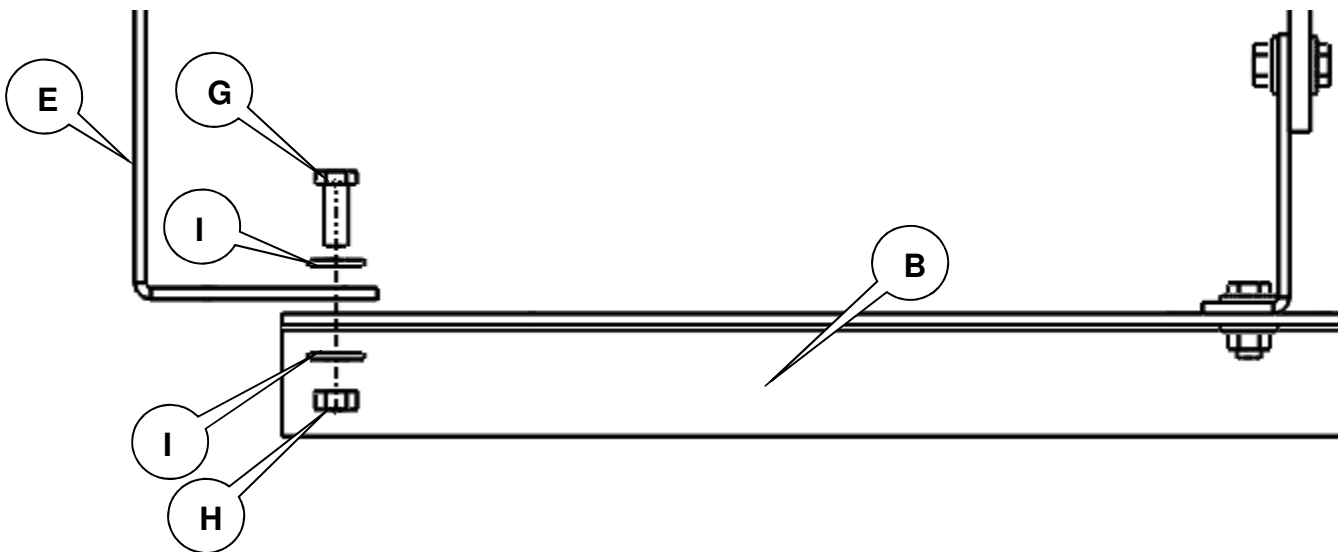

- 12** At the rear Passenger's Brace Location (Marked as 4 on the Diagram), use a Frame Bracket (E) and attach to the Angle Brace using one 1/4"-20 X1" Bolt (G), two 1/4" Washer (I), and one 1/4"-20 Nut (H) using a 7/16" Wrench or Ratchet. Do not completely tighten at this time.

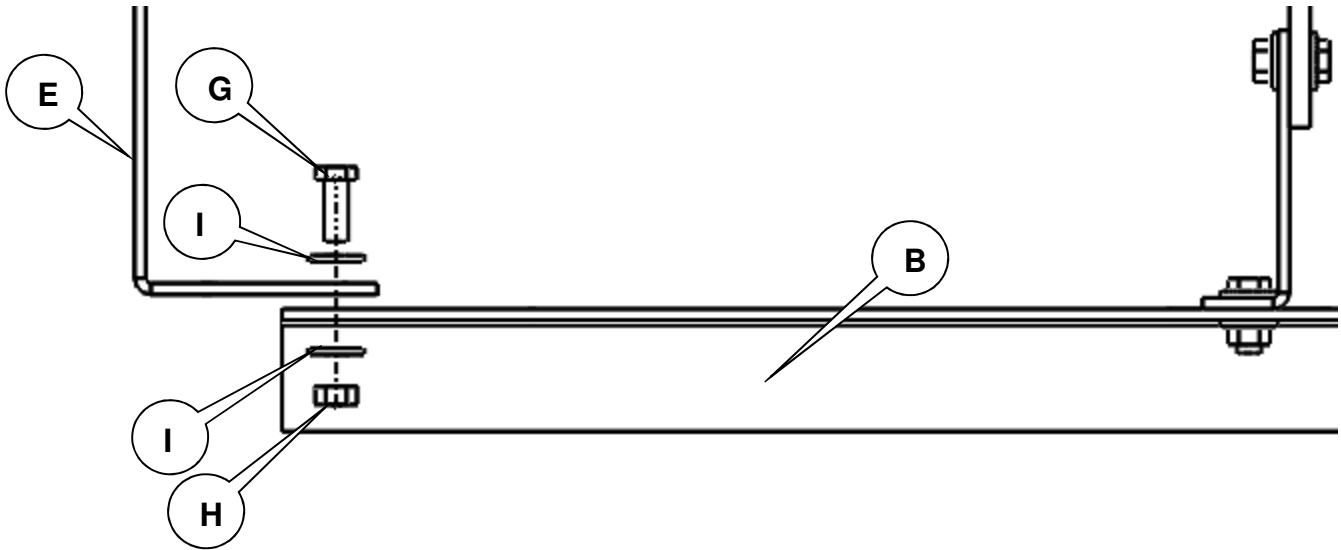

- 13** At the rear Passenger's Brace, use a Frame Bracket (E) and attach to the tube running lengthwise of the vehicle using one M8-20mm Hex Head Bolt (J). In the tube running the length of the vehicle, there is one hole that is threaded as shown below. Use this hole to install the Bolt (J) using a 13mm socket. Use a level to make sure that the Angle Brace (B) is parallel to the ground. Do not completely tighten at this time.



14 Slide two Strap Brackets (F) into the Running Boards (A).

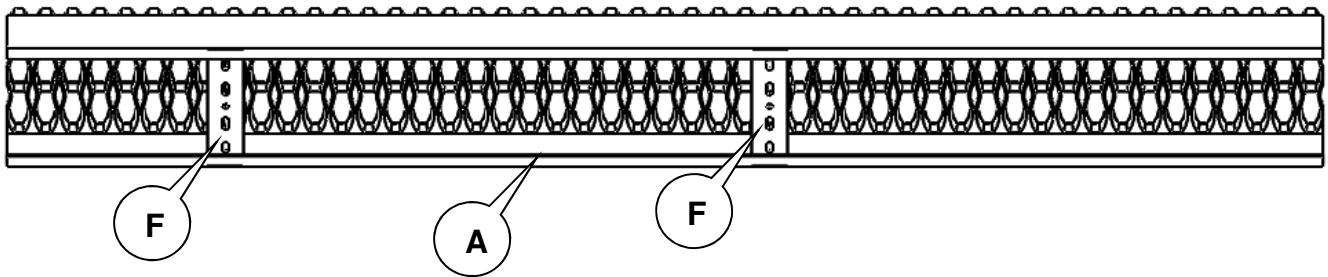

15 Attach Slide Strap Bracket (F) to Angle Brace (B) using two 1/4-20 Bolt (G), four 1/4 Washers (I), and two 1/4-20 Hex Nut (H) at each location using two 7/16" ratchets or wrenches. Do not completely tighten at this time.

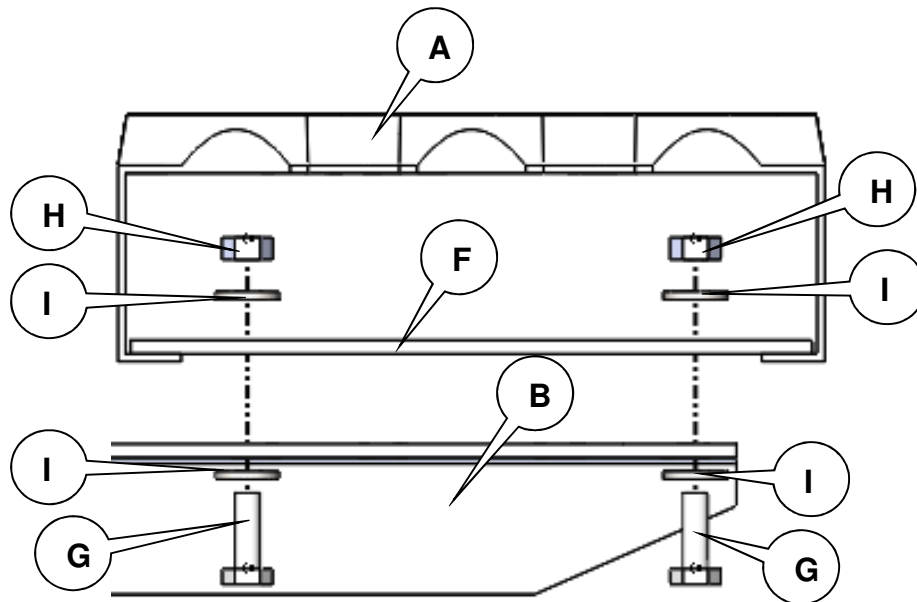

16 Attach the End Cap Assembly (that came with the Running Boards) to each end of both boards. Tighten the nut and bolt fully using two 7/16" ratchets or wrenches.

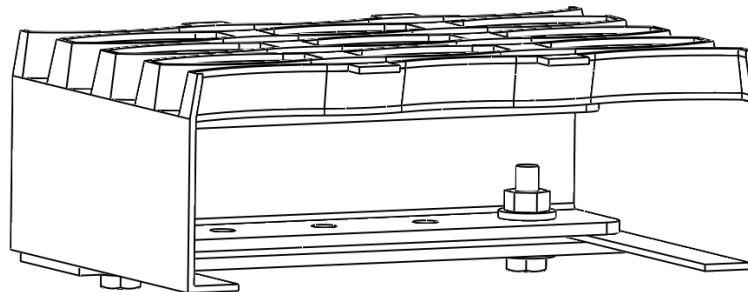

17 Before fully tightening all of the nuts and bolts, adjust the running boards so that it is in the desired position on the vehicle. After the running board is in the desired position, fully tighten all nuts and bolts.

18 Reinstall clips that are located along the plastic molding that run along the bottom of the vehicle. To do this, pull the clip down, so that the ends of the clip are in the hole located in the sheet metal. Then push up on the clip until the clip is fully re-attached.