



Dee Zee Running Board Installation Instructions

Congratulations on your purchase of a quality Dee Zee product. Dee Zee is recognized as having the highest quality running boards and accessories on the market today. We have earned this reputation by offering our customers a product they can be proud to place on their vehicles. Dee Zee meets all the criteria of manufacturing a custom-fit product which guarantees it to be the easiest product to install.

Note: Please take time to read all of the instructions before beginning this installation.

Warning! It is the sole responsibility of the vehicle owner to check for tire clearance.

Warning! It is unlawful and dangerous to ride on running boards or side box boards while vehicle is in motion.

Cleaning instructions: To maintain the finish of your Dee Zee running boards, clean with a mild detergent and use a high grade automotive type wax. **DO NOT USE ABRASIVE CLEANERS ON THIS PRODUCT!**

Rough Step Running Board Installation Instructions

DZ 15327 2015 Ford F150 Pickup

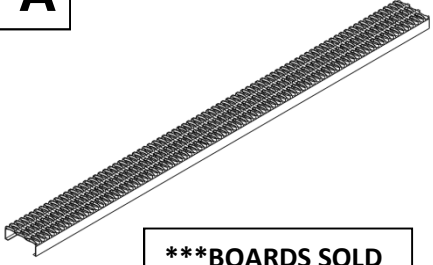
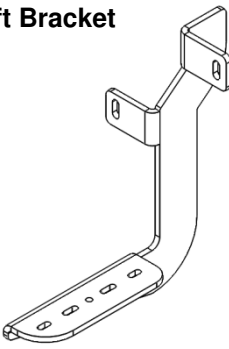
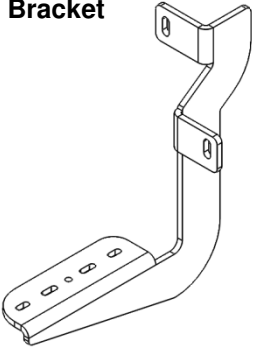
<div style="border: 1px solid black; padding: 5px; display: flex; justify-content: space-between;"> A Running Boards </div>  <div style="border: 1px solid black; padding: 5px; margin: 10px auto; width: 80%; text-align: center;"> ***BOARDS SOLD SEPERATELY </div> <div style="display: flex; justify-content: space-between; margin-top: 10px;"> Various X2 </div>	<div style="border: 1px solid black; padding: 5px; display: flex; justify-content: space-between;"> B Left Bracket </div>  <div style="display: flex; justify-content: space-between; margin-top: 10px;"> B 2289LP X3 </div>	<div style="border: 1px solid black; padding: 5px; display: flex; justify-content: space-between;"> C Right Bracket </div>  <div style="display: flex; justify-content: space-between; margin-top: 10px;"> B 2289RP X3 </div>
--	--	---

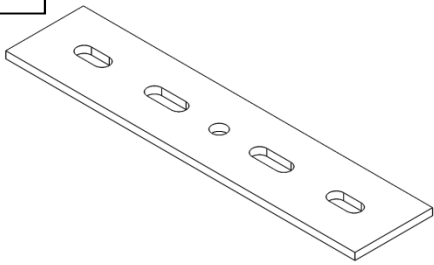
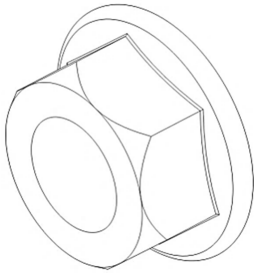
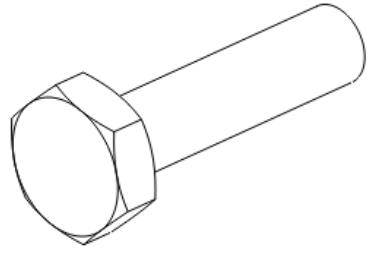
<div style="border: 1px solid black; padding: 5px; display: flex; justify-content: space-between;"> D Strap bracket </div>  <div style="display: flex; justify-content: space-between; margin-top: 10px;"> B 1791P X6 </div>	<div style="border: 1px solid black; padding: 5px; display: flex; justify-content: space-between;"> E M8 Hex Paint Clearing Nut </div>  <div style="display: flex; justify-content: space-between; margin-top: 10px;"> PN 1140 X12 </div>	<div style="border: 1px solid black; padding: 5px; display: flex; justify-content: space-between;"> F 1/4-20 X 1 1/4" Hex Head Bolt </div>  <div style="display: flex; justify-content: space-between; margin-top: 10px;"> PN 78 X12 </div>
--	---	---

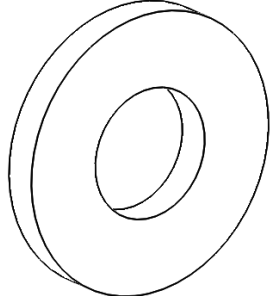
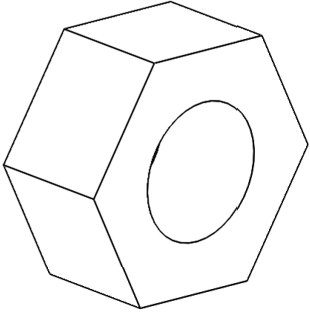
<div style="border: 1px solid black; padding: 5px; display: flex; justify-content: space-between;"> G 1/4" Washer </div>  <div style="display: flex; justify-content: space-between; margin-top: 10px;"> PN 72B X24 </div>	<div style="border: 1px solid black; padding: 5px; display: flex; justify-content: space-between;"> H 1/4-20 Hex Nut </div>  <div style="display: flex; justify-content: space-between; margin-top: 10px;"> PN 71B X12 </div>	
---	---	--

Tools Required

Ratchet / Wrench
2x 7/16"
13 mm

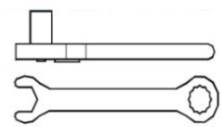

NOTE: FOR REGULAR CAB AND SUPERCAB, THE MIDDLE BRACKET LOCATION IS NOT AVAILABLE. PROCEED AS DIRECTED USING FRONT AND REAR MOUNTING LOCATIONS. THE EXTRA BRACKETS AND HARDWARE MAY BE DISCARDED.

1

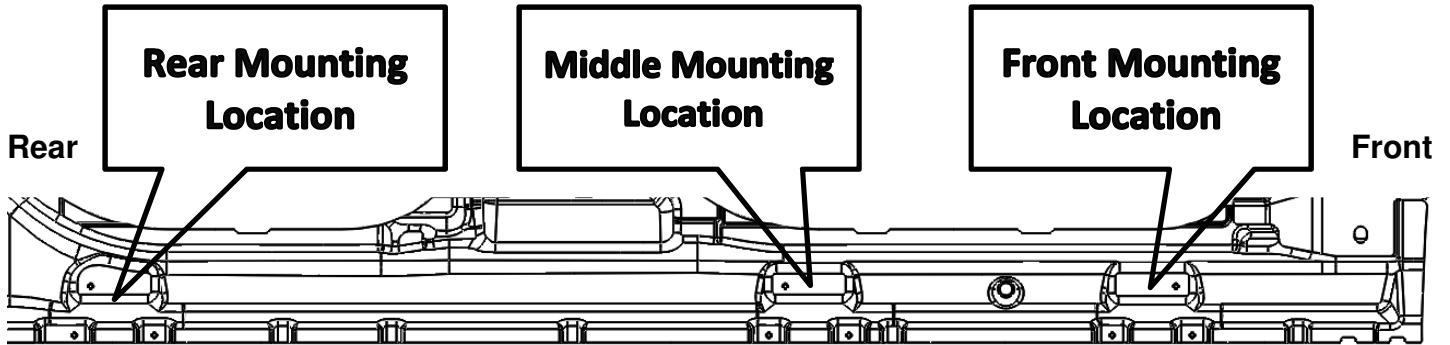

Driver's Side SuperCrew Shown Above

2

Attach a Right Bracket (C) to the Front Mounting Location with two M8 Nuts (E) by using a 13 mm ratchet or wrench. Do not completely tighten the nuts at this time.

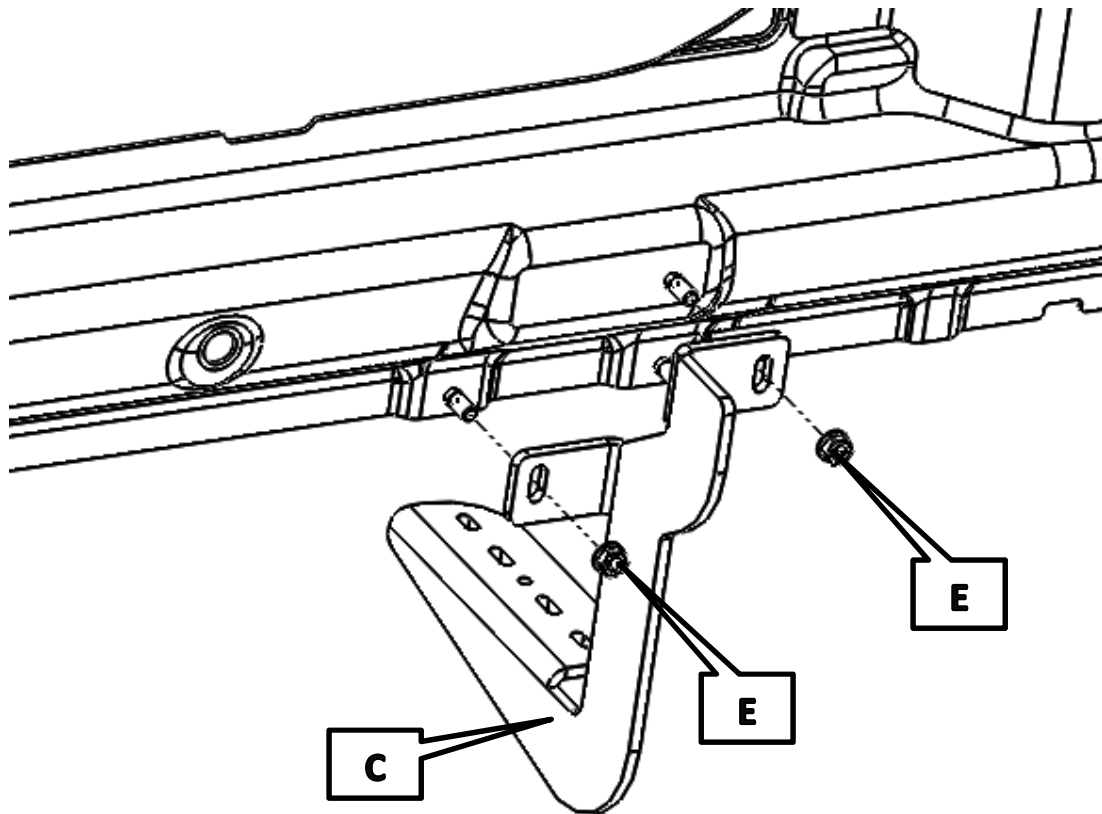

- 3** Attach a Left Bracket (B) to the Middle Mounting Location with two M8 Nuts (E) by using a 13 mm ratchet or wrench. Do not completely tighten the nuts at this time.
NOTE: SKIP THIS STEP IF THE TRUCK IS A REGULAR OR SUPERCAB.

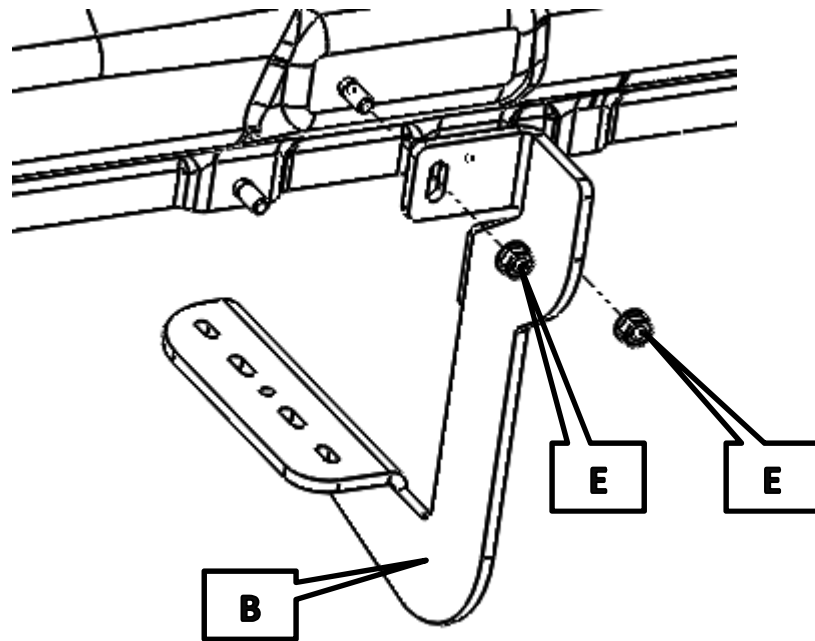

- 4** Attach a Left Bracket (B) to the Rear Mounting Location with two M8 Nuts (E) by using a 13 mm ratchet or wrench. Do not completely tighten the nuts at this time.

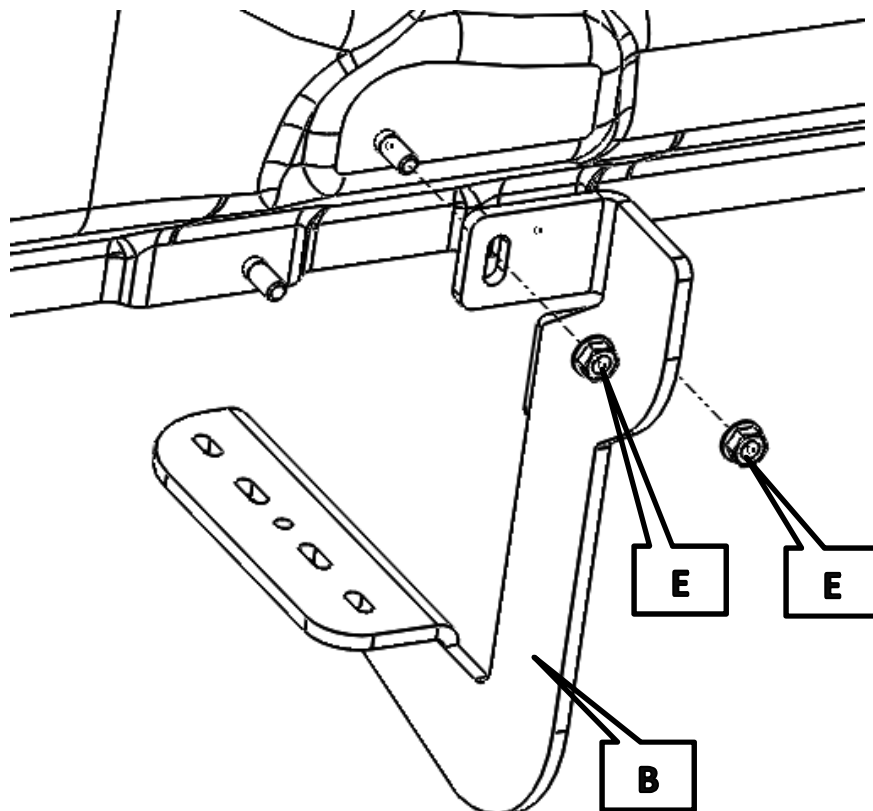

- 5** Repeat Steps 2-4 on the Passenger Side using two Right Brackets (C) and one Left Bracket (B). The Front Mounting Location on the Passenger's Side gets a Left Bracket, and the Middle and Rear Mounting Locations get a Right Bracket. Attach brackets with six M8 Nuts (G) using a 13mm ratchet or wrench. Do not completely tighten the nuts at this time.

- 6** Slide Strap Bracket (D) into the Running Boards (A). For SuperCrew slide three into each board, while for Regular and SuperCab slide two into each board.

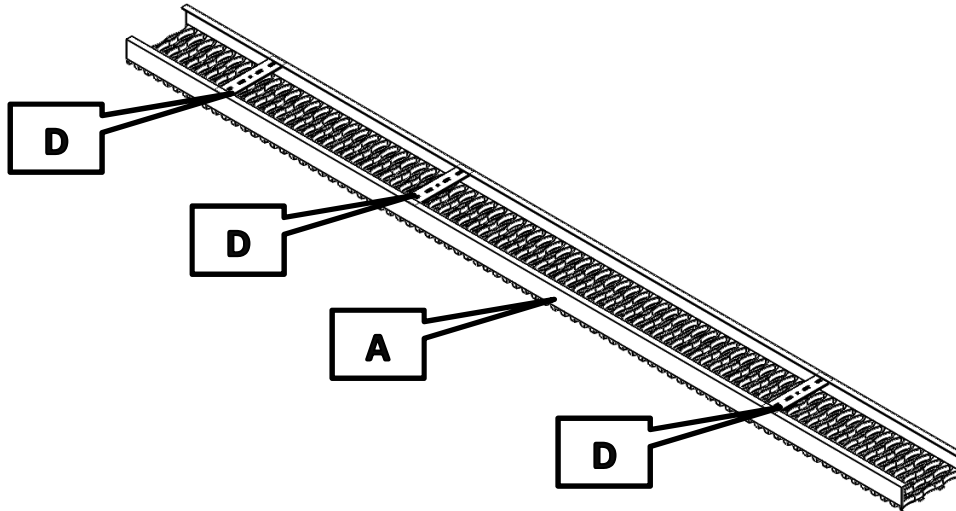

- 7** Attach Slide Strap Bracket (D) to Right and Left Brackets (B&C) using two 1/4-20 Bolt (F), four 1/4 Washers (G), and two 1/4-20 Hex Nut (H) at each location using two 7/16" ratchets or wrenches. Do not completely tighten at this time.

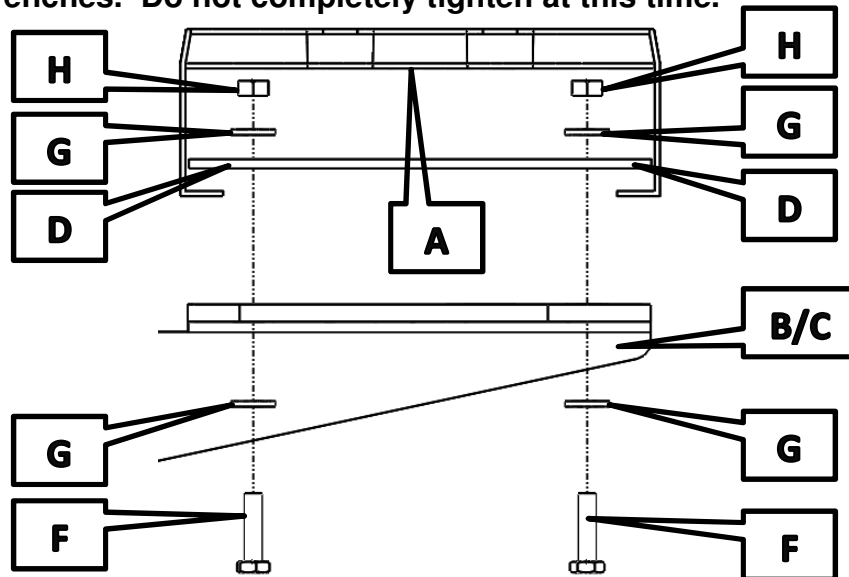

NOTE: Running board cut to show features.

8

Attach the End Cap Assembly to each end of both boards. Tighten the nut and bolt fully using two 7/16" ratchets or wrenches.

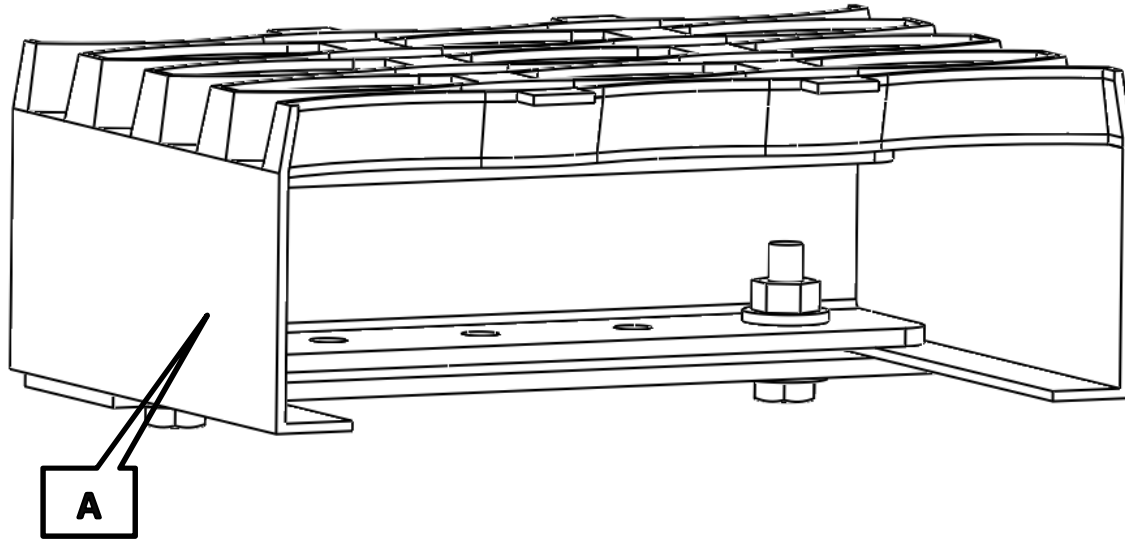

NOTE: Running board cut to show features.

9

Before fully tightening all of the nuts and bolts, adjust the running boards so that it is in the desired position on the vehicle. After the running board is in the desired position, fully tighten the nuts (H &E) and bolts (F).