



Dee Zee Running Board Installation Instructions

Congratulations on your purchase of a quality Dee Zee product. Dee Zee is recognized as having the highest quality running boards and accessories on the market today. We have earned this reputation by offering our customers a product they can be proud to place on their vehicles. Dee Zee meets all the criteria of manufacturing a custom-fit product which guarantees it to be the easiest product to install.

Note: Please take time to read all of the instructions before beginning this installation.

Warning! Please check for wiring or other obstructions before drilling any holes into the vehicle. If it is necessary to drill any holes into the vehicle, Dee Zee recommends putting a sealant or rust inhibitor around all holes drilled into the body of the vehicle.





Warning! It is the sole responsibility of the vehicle owner to check for tire clearance.

Warning! It is unlawful and dangerous to ride on running boards or side box boards while the vehicle is in motion.

Cleaning Instructions: To maintain the bright finish of your Dee Zee running boards, clean with a mild detergent. For our stainless steel products and accessories, the application of a high grade automotive type wax is recommended.

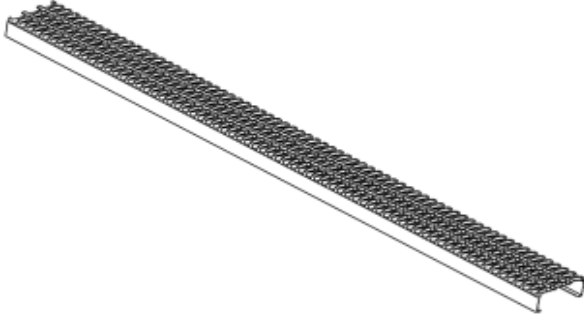
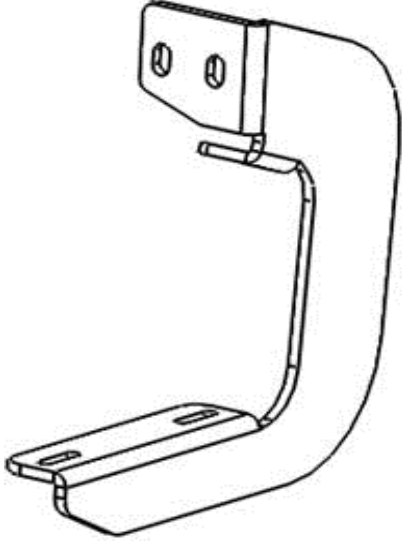
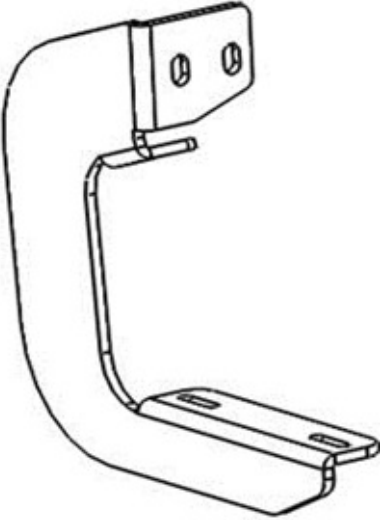
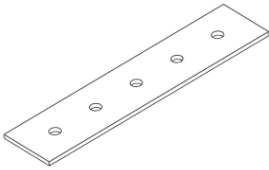
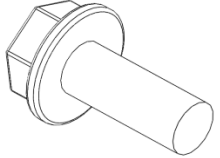
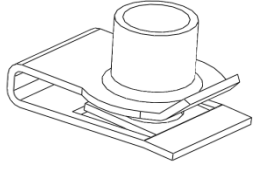
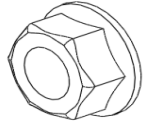
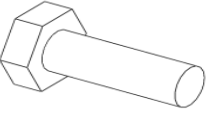
ROUGH STEP RUNNING BOARD INSTALLATION INSTRUCTION

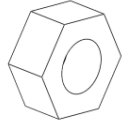
DZ 15325 FORD F-150 2009-2014

<p>A</p>  <p style="text-align: center;">SIDE STEP TUBE</p> <p>*** BOARD SOLD SEPARATELY</p>	<p>B</p>  <p style="text-align: center;">LEFT BRACE</p>	<p>C</p>  <p style="text-align: center;">RIGHT BRACE</p>	<p>D</p>  <p style="text-align: center;">STRAP BRACKET</p>
VARIES	X2 B 2216LP	X3	X3
<p>E</p>  <p style="text-align: center;">8mm X 25mm FLANGE HEAD BOLT</p>	<p>F</p>  <p style="text-align: center;">8mm U-NUT</p>	<p>G</p>  <p style="text-align: center;">8mm NUT</p>	<p>H</p>  <p style="text-align: center;">1/4 X 1 1/4" HEX HEAD BOLT</p>
B 2216RP	X6 PN 525	X12	X6
<p>I</p>  <p style="text-align: center;">1/4" FLAT WASHER</p>	<p>J</p>  <p style="text-align: center;">SPLIT LOCK WASHER</p>	<p>K</p>  <p style="text-align: center;">1/4" HEX NUT</p>	<p>P</p> 
PN 78	X12	PN 72B	X24
PN 512	X12	PN 71B	X12

TOOLS REQUIRED

WRENCH/RATCHET

7/16", 13mm



1

Install the 8mm u-nut [F] as shown below.

The driver's side crew cab is shown. The front of the vehicle is to the right of the picture.

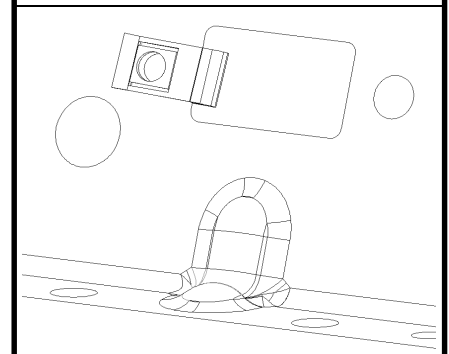
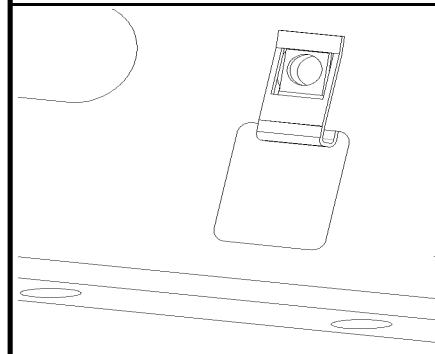
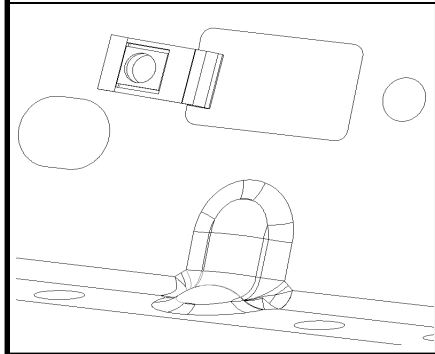
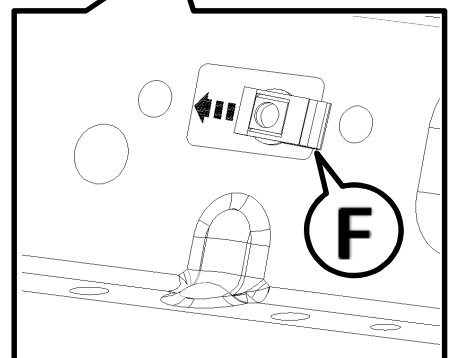
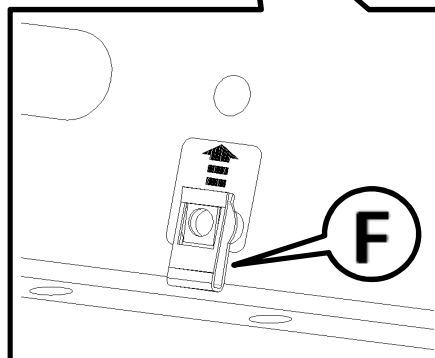
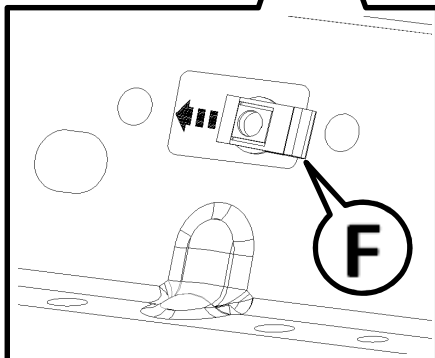
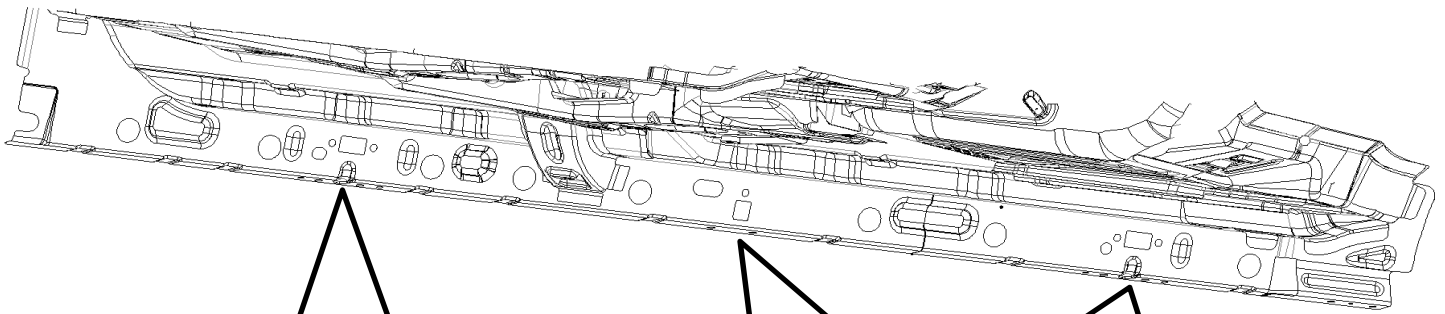

The regular cab does not have a middle mounting location. Extra brackets and hardware may be discarded.

The middle location for the extended cab will be like the front/rear on the crew cab.

- 2** Attached the mounting brackets [B] to the mounting locations with the previously installed U-nuts using the 8mm x 25mm bolt [E] in the top slot. Use the 8mm bolt [E] and 8mm nut [G] in the lower mounting slot. Tighten with a 13mm socket/wrench.

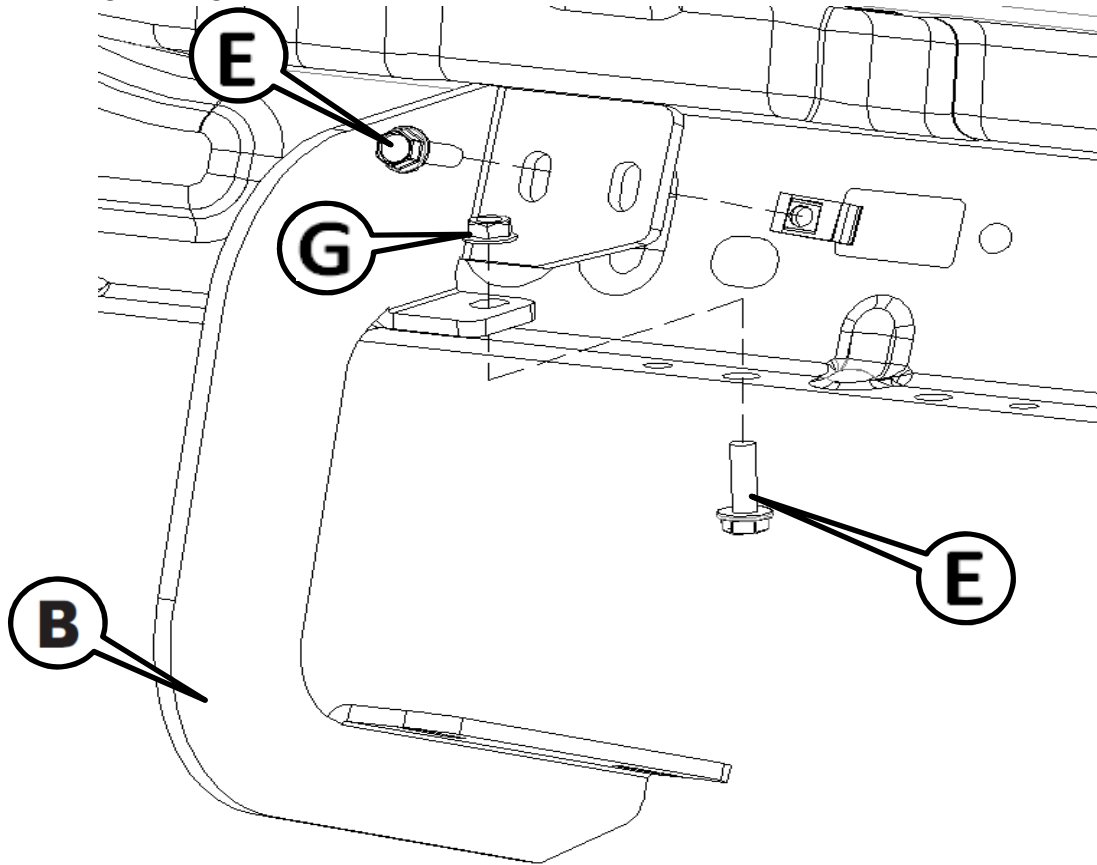

For the crew cab middle brace location, the other top slot will be used to attach the brace.

- 3** Slide the pre-assembled end cap into the end of the board [A] until the end cap is flush with the end of the board. The end cap must be inside the board and the strap bracket outside the board. Tighten the bolts with a 7/16" wrench and socket.

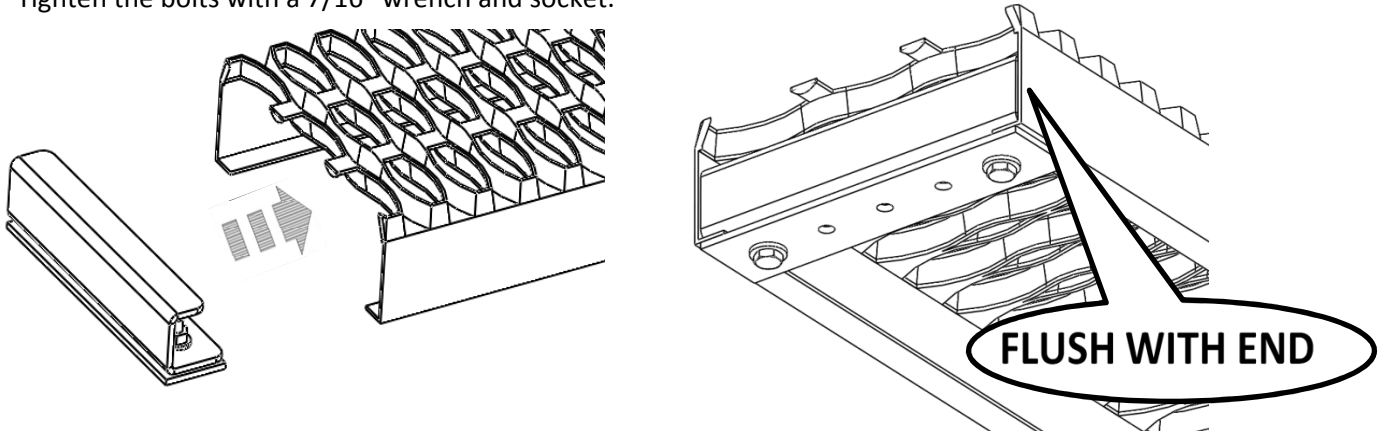

DO NOT INSTALL THE END CAP ON THE OTHER END OF THE BOARD UNTIL COMPLETING THE NEXT STEP.

If you do not have the end caps already assembled, refer to the instructions included with the running boards.

- 4** Before attaching the end cap on the other end of the board, slide the strap brackets into the open end of the board. If your application uses 2 braces per side, insert 2 strap brackets [D]. If your application uses 3 braces per side, insert 3 strap brackets [D].

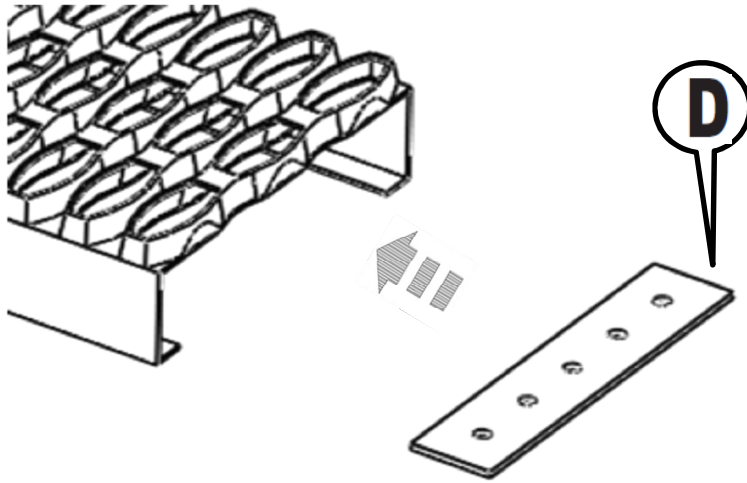

Once the strap brackets are in the board, attach the other end cap.

- 5** Place the running board on the braces and adjust front to back and side to side to get the board in the desired location.

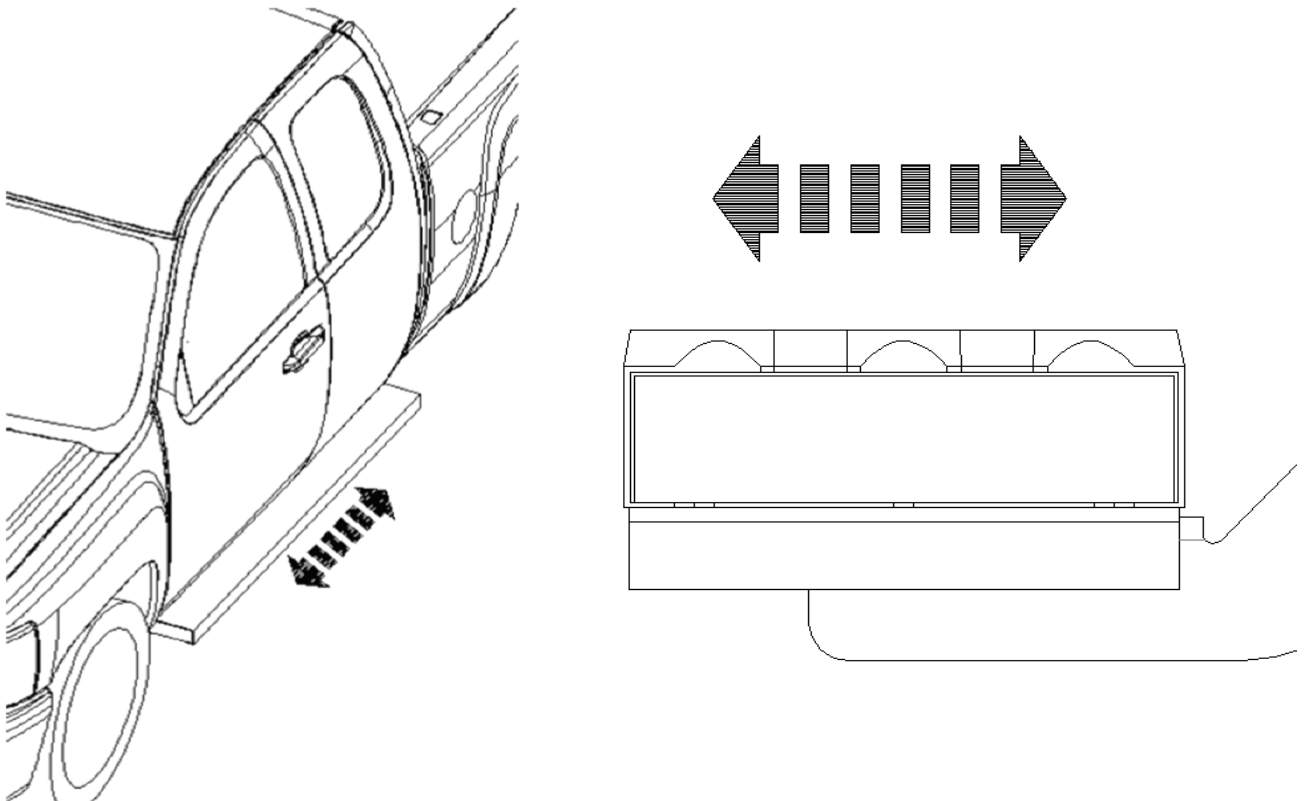

6

Align the strap brackets [D] that were installed in Step 4 with the main braces.

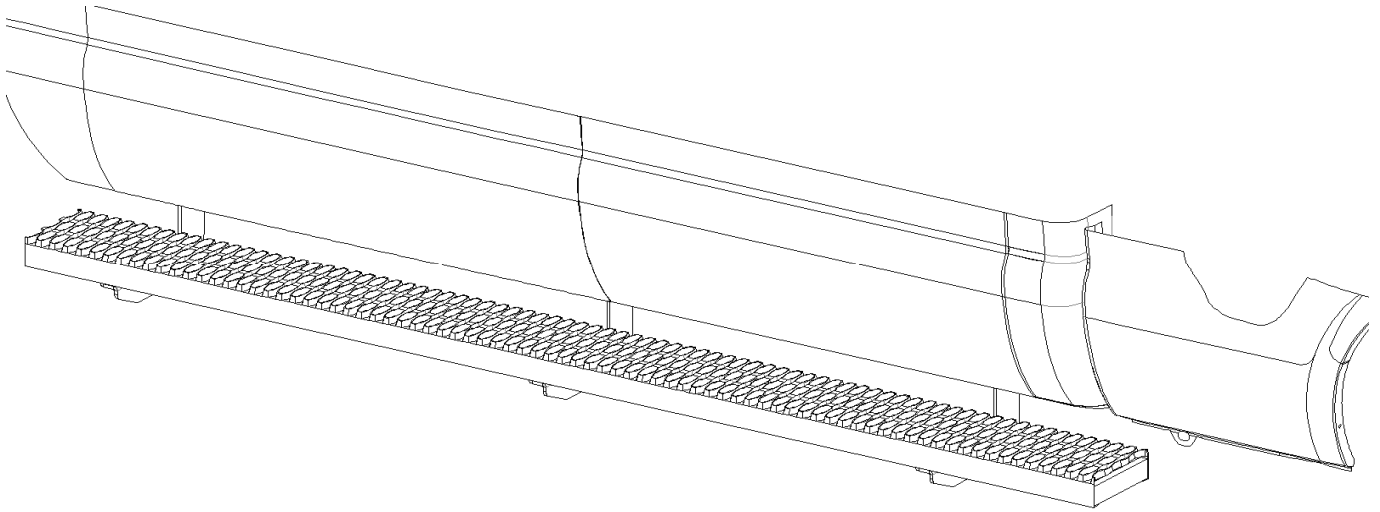

Attach the board to the brace using the 1/4" bolt [H], two washers [I], lock washer [J], and nut [K].
Tighten all bolts using a 7/16" socket/wrench.
Make sure all bolts are tightened. Repeat steps for other side.

