



## INSPECT YOUR PRODUCT FOR DAMAGE & MISSING PARTS BEFORE PROCEEDING TO INSTALLATION

Thank you for choosing Dee Zee to add function and accessorize your vehicle. Dee Zee has been a staple brand in the truck accessory market since 1977 and we hold a reputation of quality manufacturing based in America's Heartland. Our products are born through careful engineering and backed by industry leading warranty programs. We appreciate the opportunity to serve you and your vehicle!

### Review the instruction pages in their entirety to prepare the required tools

**Warning:** Please check for wiring or other obstructions before drilling any holes in the vehicle. If it is necessary to drill any holes, Dee Zee recommends putting a sealant or rust inhibitory around all holes drilled into the body of the vehicle.

It is the sole responsibility of the vehicle owner to check for tire clearance. It is unlawful and dangerous to ride on any external vehicle step while the vehicle is in motion.

**Cleaning:** To be entitled to all warranty rights offered with the product, Dee Zee steps need to be cleaned regularly with a mild detergent. Do NOT use abrasive cleaners. For stainless steel products, the application of a high grade automotive wax is recommended.







### **WARNING:**

Operating, servicing, and maintaining a passenger vehicle can expose you to chemicals such as lead, phthalates, engine exhaust, and carbon monoxide that are known to the State of California cause cancer and birth defects or other reproductive harm. To minimize exposure, service your vehicle and its accessories in a well-vented area and wear gloves or wash your hands frequently.

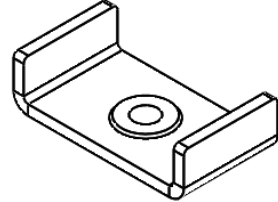

# Hex Series Side Rail Installation Instructions

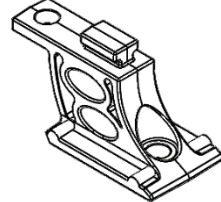
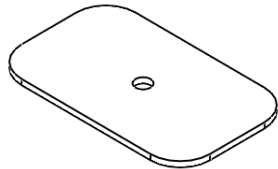
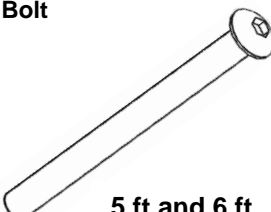
## DZ99707, DZ99708, DZ99709 Ford F150 04-18 and Super Duty 17-Current

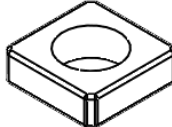
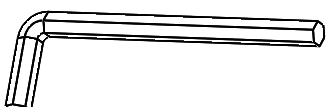
<p><b>A</b> Hex Side Rail</p>  <p>Various X2</p>	<p><b>B</b> Endcap</p>  <p>EC DZE-581ASSY X4</p>	<p><b>C</b> Front and Rear Bracket</p>  <p>B 2571PN X4</p>
<p><b>D</b> Middle Bracket</p> <p><b>ONLY USED ON 8ft BED</b></p>  <p>B 2568PN X2</p>	<p><b>E</b> Stanchion</p>  <p>5 ft and 6 ft X4 8ft X6</p> <p>SRS HEX</p>	<p><b>F</b> Plate</p>  <p>5 ft and 6 ft X4 8ft X6</p> <p>B 2570</p>
<p><b>G</b> 8mm X 90mm Button Head Bolt</p>  <p>5 ft and 6 ft X4 8ft X6</p> <p>PN 1281</p>	<p><b>H</b> 8mm X 14 Bolt</p>  <p>5 ft and 6 ft X4 8ft X6</p> <p>PN 247</p>	<p><b>I</b> 8mm X 1.25 Square Nut</p>  <p>5 ft and 6 ft X4 8ft X6</p> <p>PN 1262</p>
<p><b>J</b> 5mm Allen Wrench</p>  <p>PN 1282 X1</p>		

### Tools Required

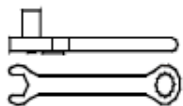

Ratchet / Wrench  
13mm



Straight Blade  
Screwdriver

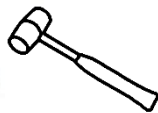

Rubber Mallet

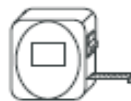

Tape Measure

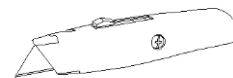

Utility Knife



Drill  
3/8"

1

First use the screwdriver to pry up on the stake pocket cover as shown from the front and middle and rear locations. Only the 8 foot bed application has a middle location. If you have a 5' bed you will need to cut the bed cap to uncover the stake pocket. Drill a hole in the X on the template or measure from the front of the bed cap and the inside of the truck bed. Then cut out the rectangle of the template.

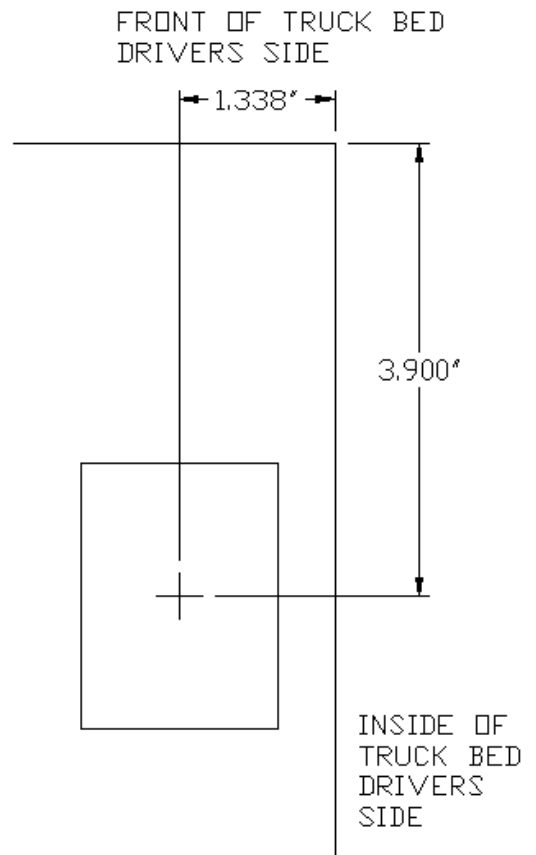
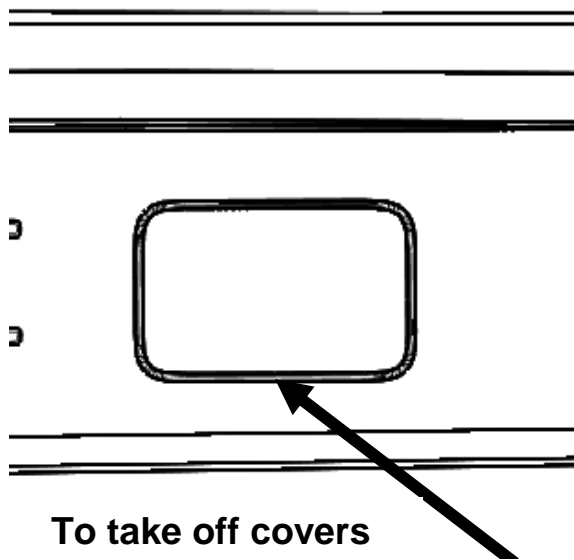

TEMPLATES ARE ON THE LAST PAGE OF INSTRUCTIONS

2

Install all endcaps (B) on the rails (A) by first hand pushing them to set in place, then hitting them with a rubber mallet.

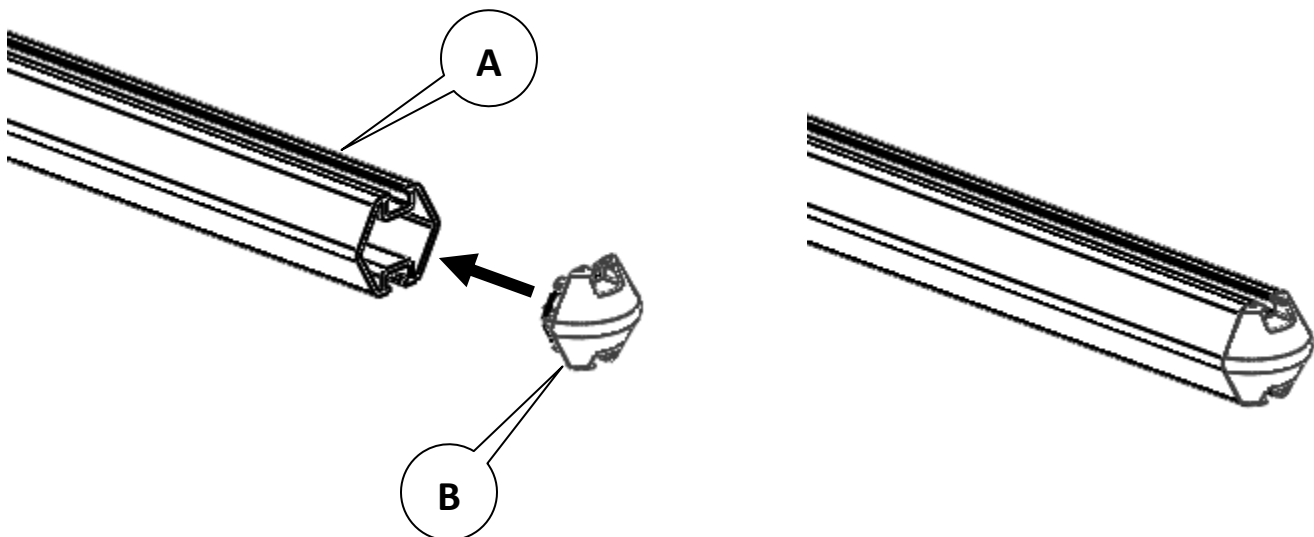

**3**

Assemble the front bracket by putting the bolt (G) through the stanchion (E) then through the plate (F) and thread a front bracket (C) onto the bolt. Repeat this step for the rear bracket.

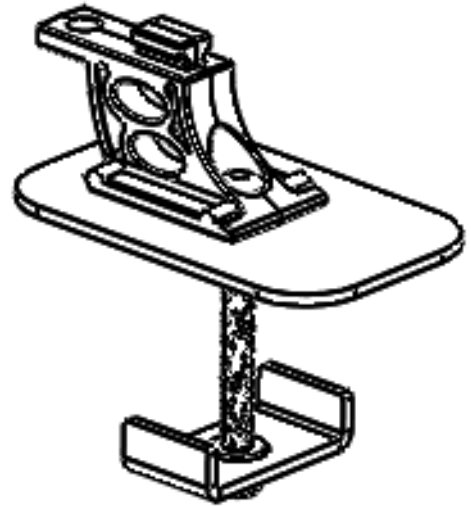
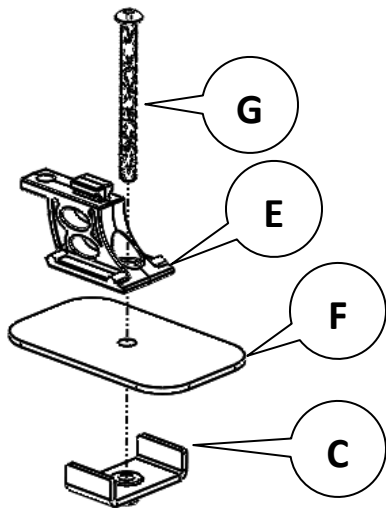
**4**

Install the front bracket assembly from step 3 into the front stake pocket. Twist the front bracket so that the bracket is perpendicular with the truck bed. Hand tighten the bolt. Do not fully tighten hardware at this time. Repeat this step in the rear location on the truck bed.

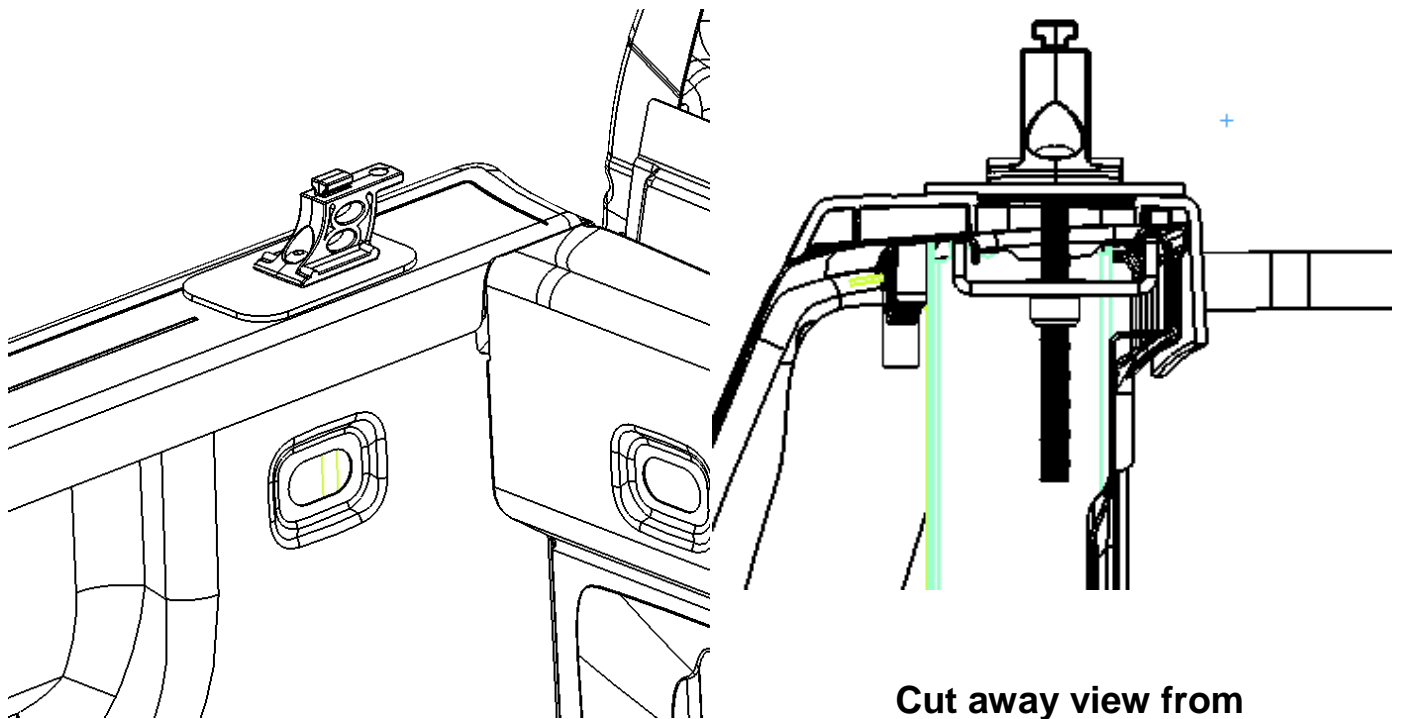

Cut away view from  
the back

- 5** Skip this step if you do not have an 8 foot truck bed. If you do have an 8 foot truck bed, assemble the middle bracket by putting the bolt (G) through the stanchion (E) then through the plate (F) and thread a middle bracket (C) onto the bolt. Hand tighten bolt. Do not fully tighten at this time.

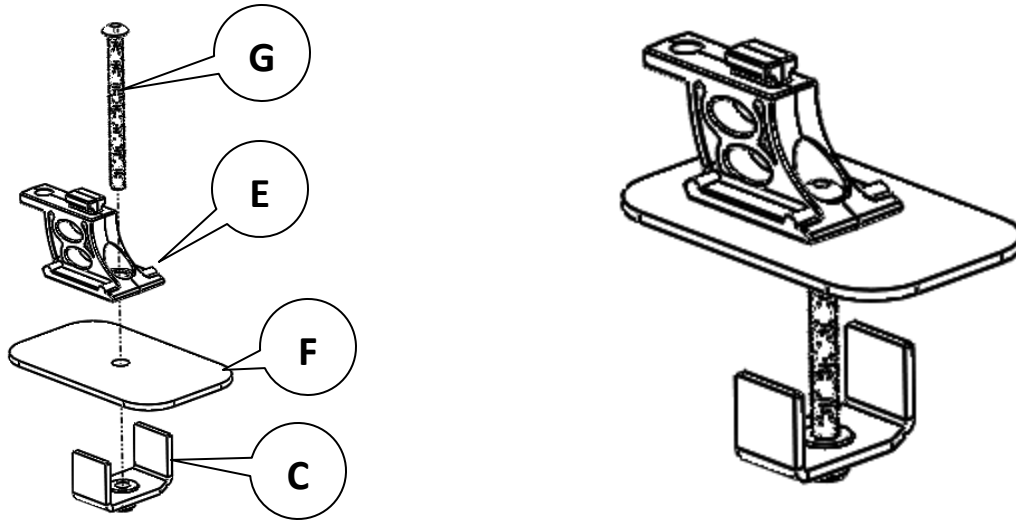

- 6** Skip this step if you do not have an 8 foot truck bed. If you do have an 8 foot truck bed, install the middle bracket assembly from step 5 into the middle stake pocket. Twist the middle bracket so that the bracket is perpendicular with the truck bed. Hand tighten the bolt. Do not fully tighten hardware at this time.

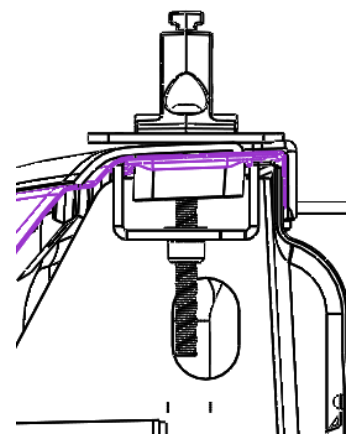
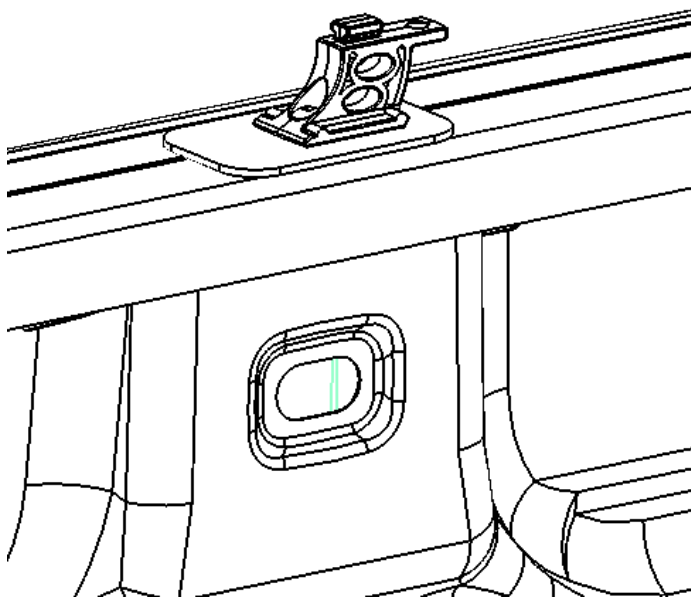

**Cut away view from  
the back**

**7**

Install bolt (H) and square nut (I) through the upper hole of the stanchions in all locations and slide rail through the stanchions and square nuts. Center the rail and Fully tighten all hardware at this time using the allen wrench (J) provided.

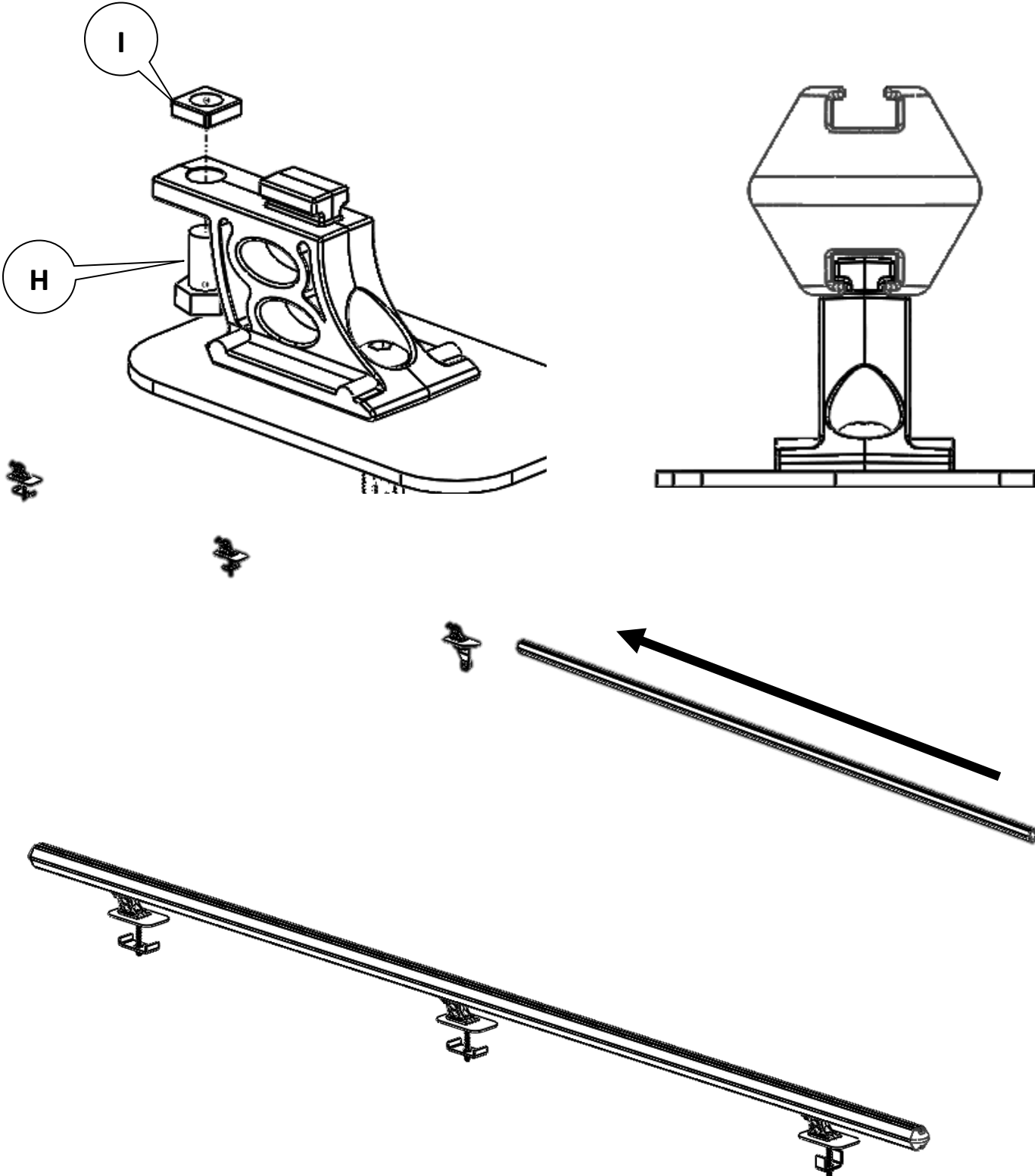

DZ 99707,8,9