



**PLEASE INSPECT YOUR PRODUCT FOR DAMAGE  
BEFORE PROCEEDING TO INSTALLATION**

Thank you for choosing Dee Zee to add function and accessorize your vehicle. Dee Zee has been a staple brand in the truck accessory market since 1977 and we hold a reputation of quality manufacturing based in America's Heartland. Our products are born through careful engineering and backed by industry leading warranty programs. We appreciate the opportunity to serve you and your vehicle!











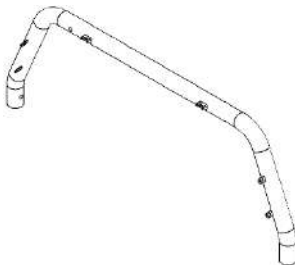
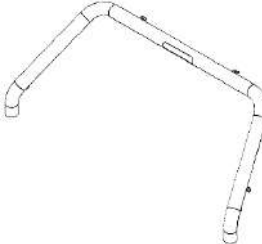

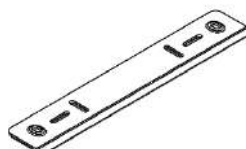
**Review the instruction pages in their entirety to prepare the required tools**

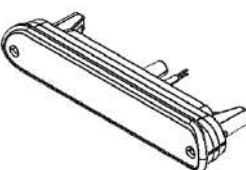
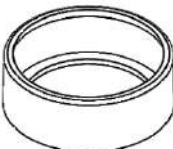

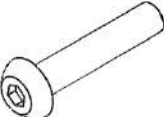

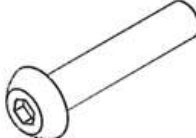

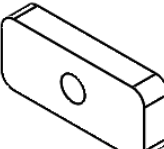

**Note:** This product is an appearance accessory and should not be relied upon as protection for the vehicle occupants in the event of an accident. Buyer assumes all risk, liability, and costs for vehicle impact operations.

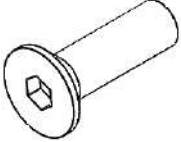
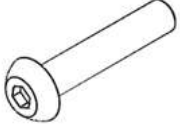
Any modifications or unintended use of this product shall immediately void all manufacturers' warranties. Dee Zee, Inc. disclaims all liability for injuries to persons or property resulting from modifications or unintended use of this product.

**Cleaning:** To be entitled to all warranty rights offered with the product, Dee Zee sport bars need to be cleaned regularly with a mild detergent. Do NOT use abrasive cleaners.

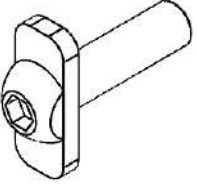
# Sport Bar DZ 960050B Installation Instructions

<p><b>A</b> Front Bar</p>  <p style="text-align: right;">X1</p>	<p><b>B</b> Back Bar</p>  <p style="text-align: right;">X1</p>	<p><b>C</b> Top Bracket</p>  <p style="text-align: right;">X1</p>	
<p><b>D</b> Bed Bracket</p>  <p style="text-align: right;">X2</p>	<p><b>E</b> Driver Side Plate</p>  <p style="text-align: right;">X1</p>	<p><b>F</b> Passenger Side Plate</p>  <p style="text-align: right;">X1</p>	
<p><b>G</b> Rear Brake Light</p>  <p style="text-align: right;">X1</p>	<p><b>H</b> Rubber Boot</p>  <p style="text-align: right;">X4</p>	<p><b>I</b> Rubber Grommet</p>  <p style="text-align: right;">X3</p>	
<p><b>J</b> 4mm Allen Head Bolt</p>  <p style="text-align: right;">X2</p>	<p><b>K</b> 4mm Lock Washer</p>  <p style="text-align: right;">X2</p>	<p><b>L</b> 4mm Flat Washer</p>  <p style="text-align: right;">X2</p>	<p><b>M</b> 8mm Allen Head Bolt</p>  <p style="text-align: right;">X2</p>
<p><b>N</b> 8mm Flat Washer</p>  <p style="text-align: right;">X4</p>	<p><b>O</b> Steel block</p>  <p style="text-align: right;">X2</p>	<p><b>P</b> 8mm Lock Washer</p>  <p style="text-align: right;">X2</p>	<p><b>Q</b> 8mm Nut</p>  <p style="text-align: right;">X2</p>

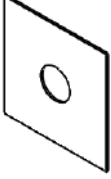
<b>R</b> 12mm -1.75 Flat Socket Bolt  X4	<b>S</b> 6mm Allen Head Bolt  X10	<b>T</b> 6mm Lock Washer  X10	<b>U</b> 6mm Flat Washer  X20
<b>V</b> 6mm Nut  X10	<b>W</b> 12mm Welded Bolt  X4	<b>X</b> 12mm Flat Washer  X4	<b>Y</b> 12mm Lock Washer  X4
<b>Z</b> 12mm Nut  X4	<b>AA</b> 12mm Rubber Cover  X4	<b>AB</b> 12mm Plastic Washer  X8	

**Tools Required**

**Allen Wrench**  
SUPPLIED



**Drill**  
1/2" Drill Bit



**Ratchet and Socket  
or Wrench**  
10mm  
13mm

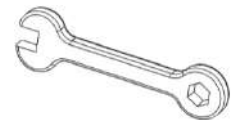

**1**

Install the rubber grommet (I) in the back bar (B) then feed the wires for the third brake light through the grommet. Then install the third brake light (G) using bolt (J), lock washer (L) and lock washer (K). Fully tighten hardware. Install rubber grommets (I) into the front bar (A) as shown.

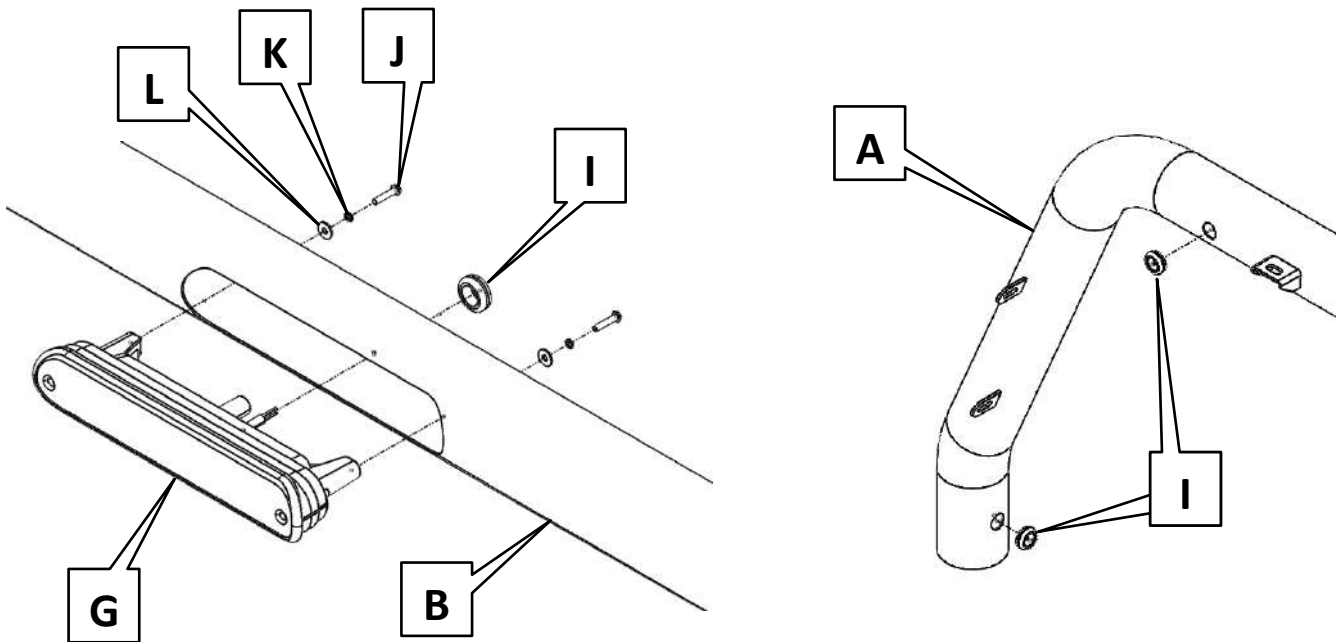
**2**

Next the front bar (A) and the rear bar (B) need to come together. The rear bar tabs will go underneath the front bar tabs. Place the steel blocks (O) on top of the tabs then install the top bracket (C). Use bolts (M), washers (N), lock washers (P) and nuts (Q) to secure the front bar, rear bar, and top bracket together. Center top bracket and Fully tighten hardware.

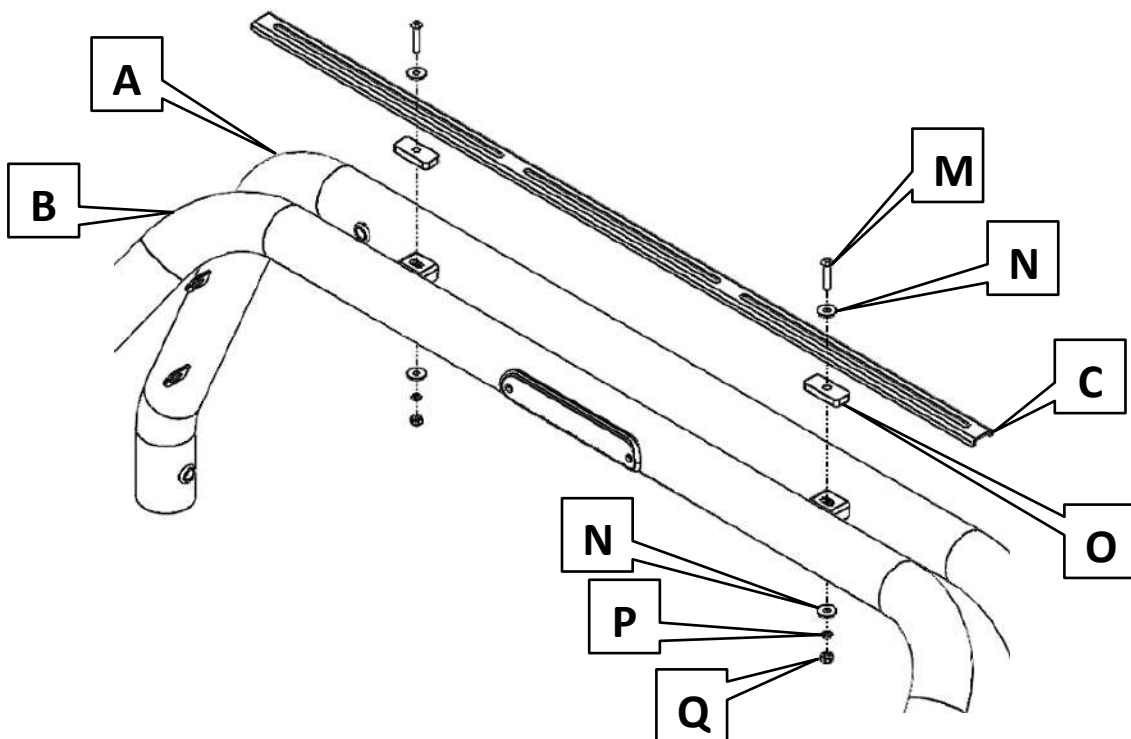

3

Feed the wires from the third brake light to the upper hole of the front bar where the grommet was installed in step 1. Run the wires into the front bar, down to the lower hole of the front bar and bring the wires out of the lower hole.

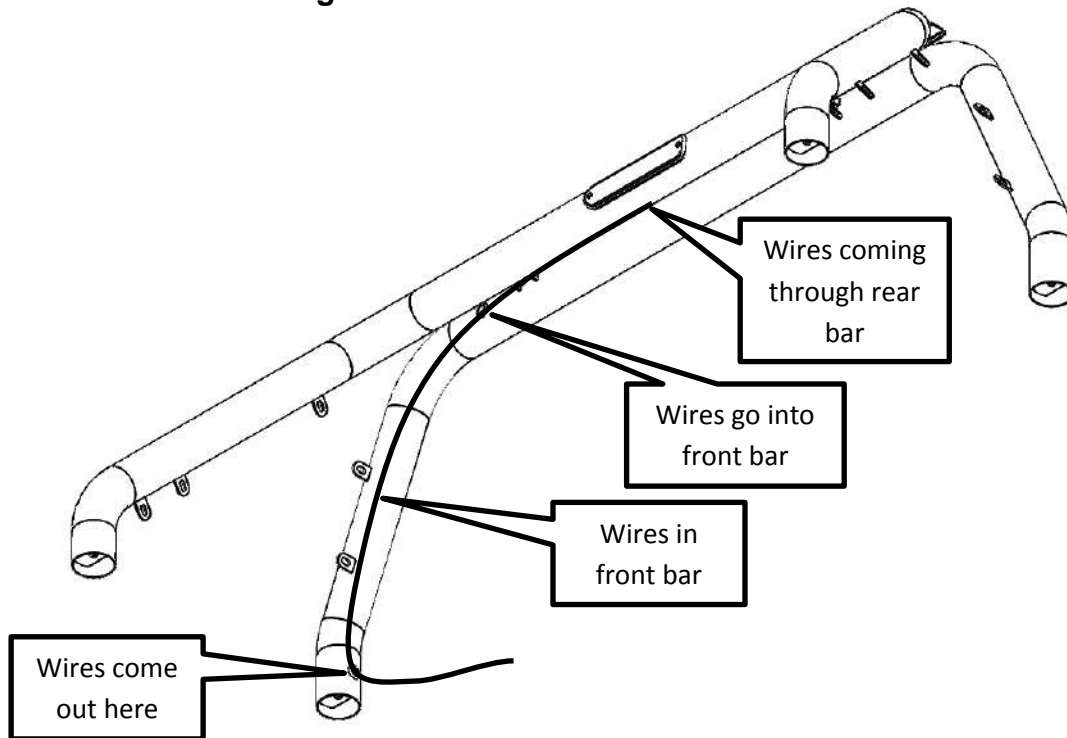

4

Install rubber boots (H) on the ends of the front and rear bars. Then install the bed brackets (D) using bolts (R). Bends on the bed brackets are on the outside of the sport bar and facing down. Do not fully tighten hardware at this time.

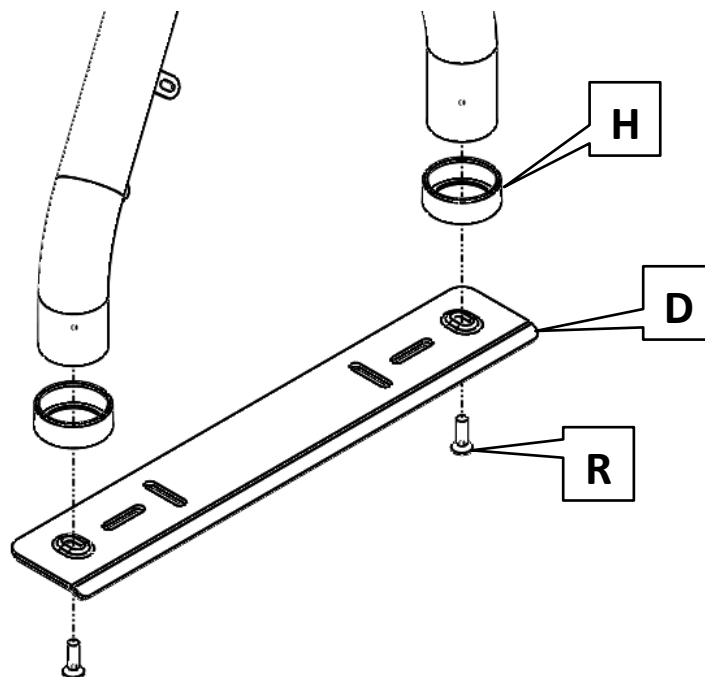

- 5** Install driver side plate (E) by using bolts (S), lock washers (T) flat washers (U) and nuts (V). Then repeat on passenger side using the passenger side plate (F). Fully tighten hardware.

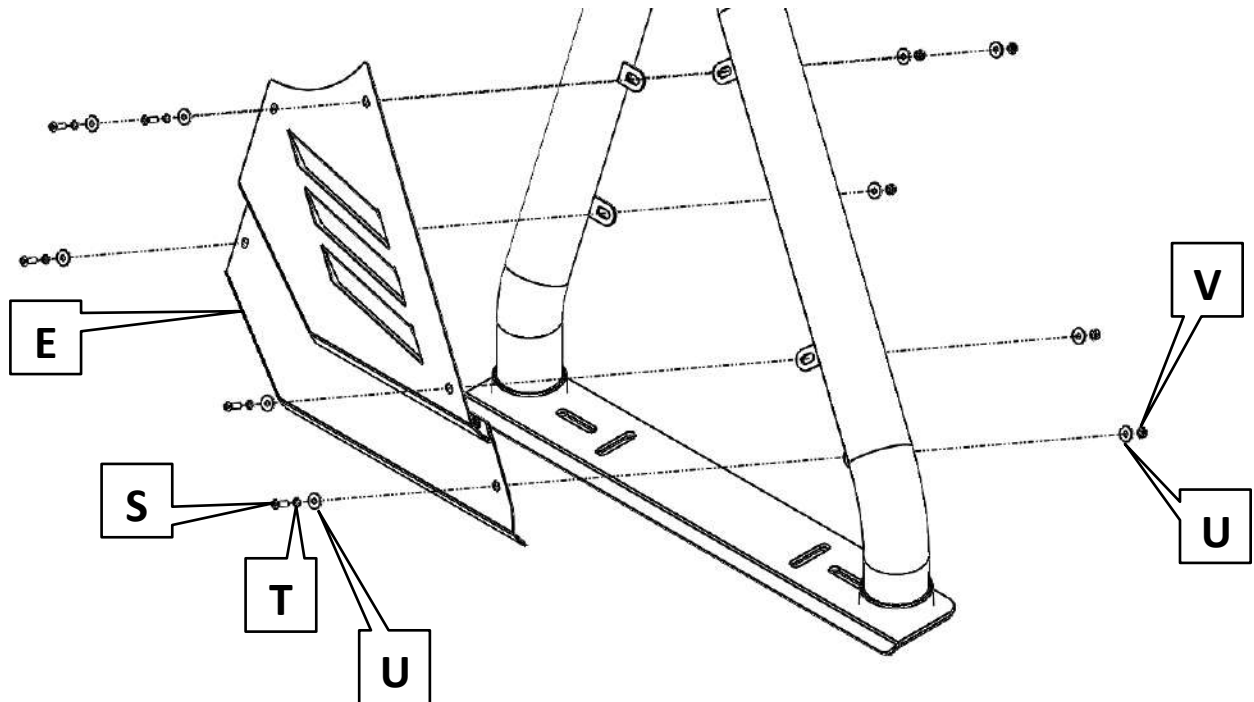

- 6** Place the sport bar assembly on the bed and adjust the bed brackets to desired position. Mark the bed caps in the inner slots of the bed brackets to locate where the holes need to be drilled. Remove the sport bar and fully tighten the bed brackets to the front and rear bars

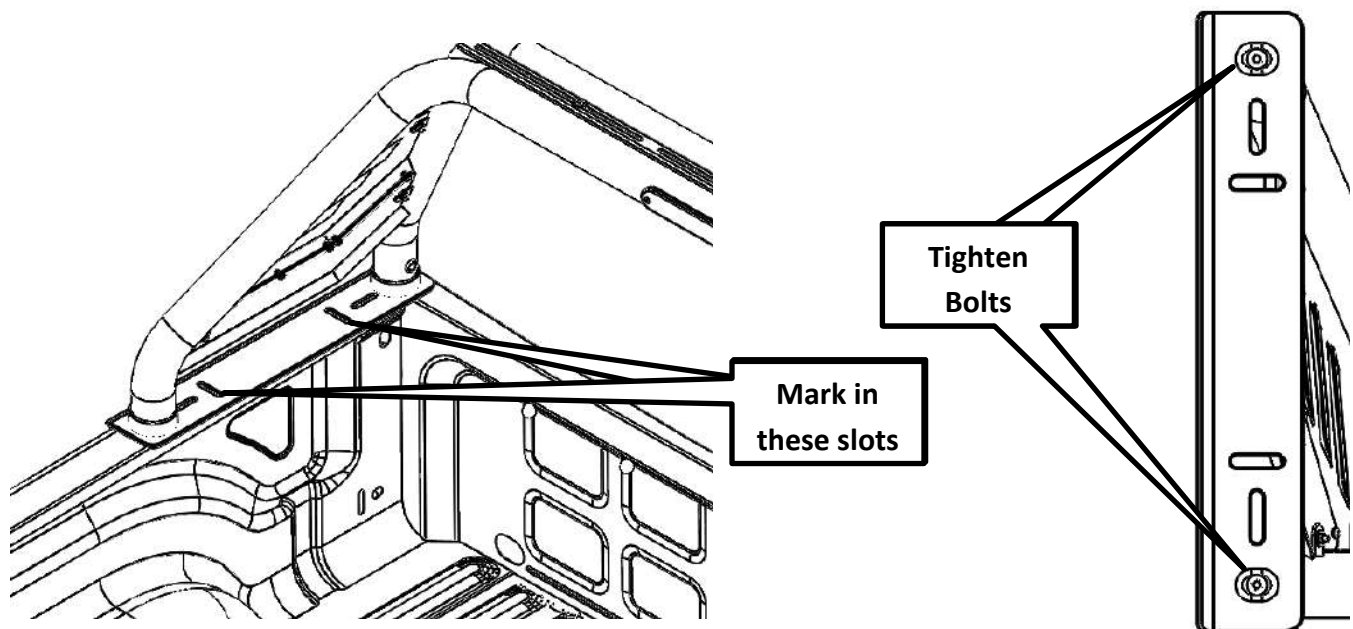

- 7** Drill holes in the middle of the marks that were made in step 6. Once the holes are drilled, place the sport bar back onto the truck bed and line up the holes with the slots.



Drill Holes

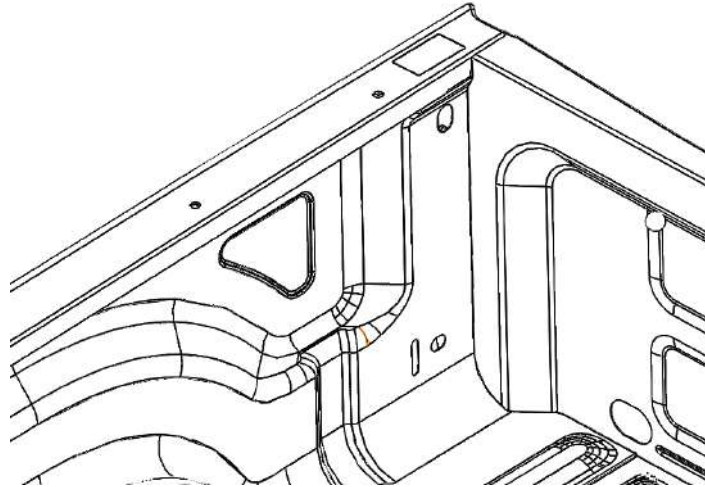



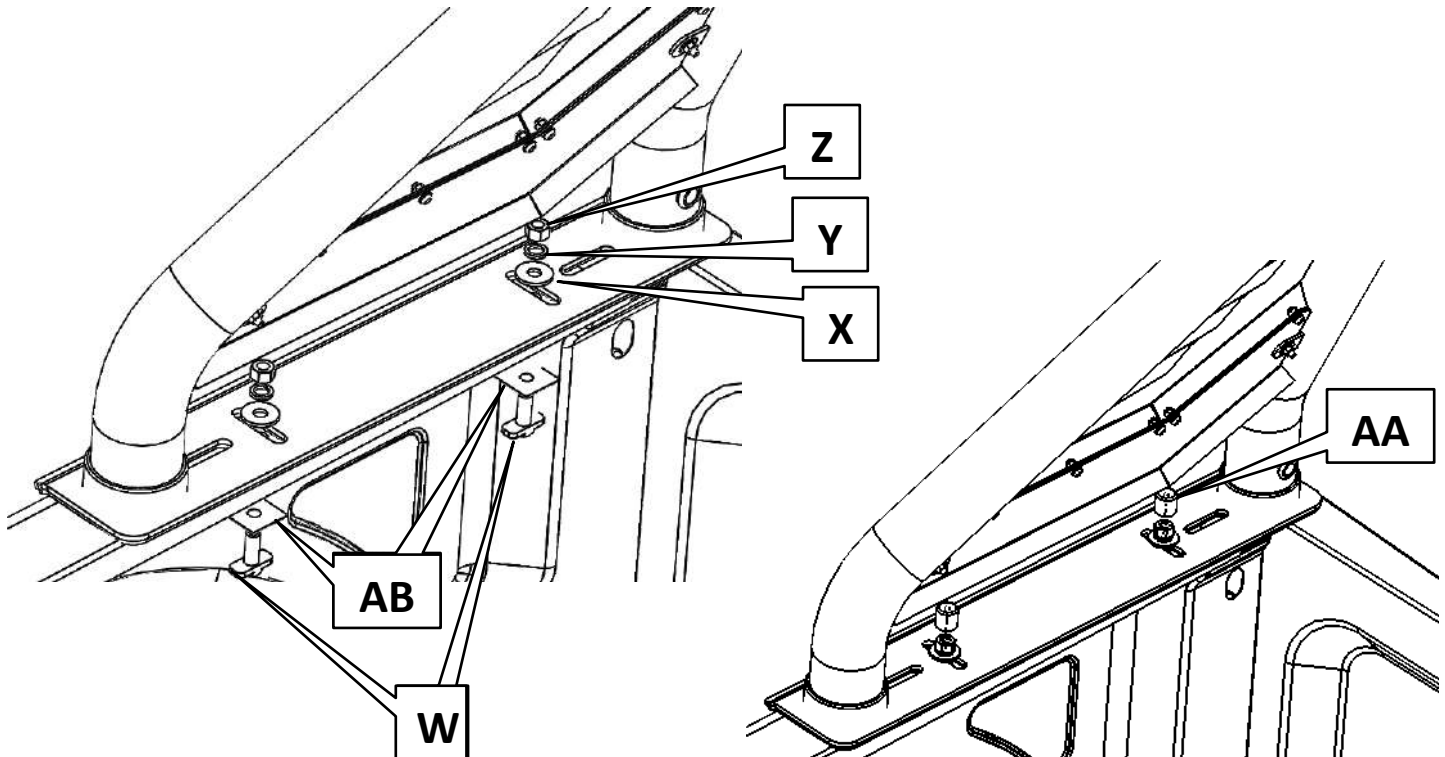

- 8** Install sport bar assembly using bolts (W), plastic washers (AB), washers (X), lock washers (Y) and nuts (Z). Center the sport bar and fully tighten hardware at this time. Then install the rubber cover (AA) onto nut (Z).



## Sport Bar Wiring Instructions

Make	Year	Go to Page
Chevy/GMC	1999-2007	10
Chevy/GMC	2007-2013	12
Chevy/GMC	2014+	14
Ford F150	2009-2014	16
Ford F150	2015+	18
Nissan Titan	2017+	21
Toyota Tundra	2007-2016	23

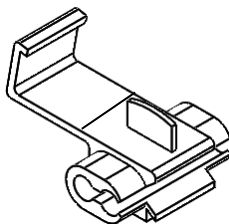
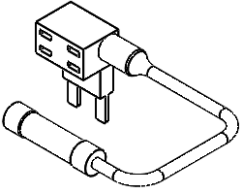
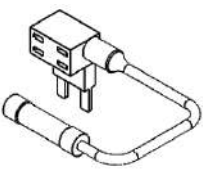
### Sport Bar Wiring Hardware

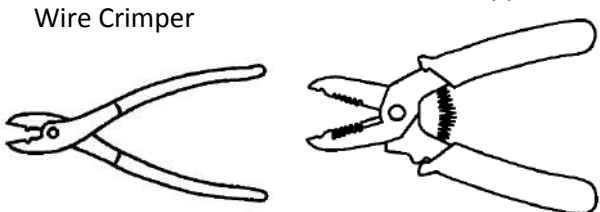
<p><b>A</b> 1/4" Eyelet</p>  <p style="text-align: right;">X1</p>	<p><b>B</b> 3/8" Eyelet</p>  <p style="text-align: right;">X1</p>	<p><b>C</b> Scotch lock</p>  <p style="text-align: right;">X1</p>
<p><b>D</b> Mini Add-A-Fuse (Bigger)</p>  <p style="text-align: right;">X1</p>	<p><b>E</b> Micro Add-A-Fuse (Smaller)</p>  <p style="text-align: right;">X1</p>	<p><b>F</b> 10 amp Micro and Mini fuses</p>  <p style="text-align: center;">X1                  X1</p>
<p><b>G</b> Zip-ties and wire loom</p>  <p style="text-align: center;">X8                          X15 Ft</p>	<p><b>Tools Required</b></p> <p style="text-align: center;">Wire Crimper                          Wire Stripper</p> 	



## Chevy/GMC 1999-2007 Wiring Instructions

- 1 Run the Red wire of the CHMSL light through the stake pocket and back to the driver side brake light. Remove the brake light and locate the Blue wire in the top light socket.

Blue wire



- 2 Run the Black wire of the CHMSL light through the stake pocket down towards the frame of the truck and locate the ground bolt as shown.

Bolt



- 3** Use the scotch lock (C) to connect the Blue wire of the tail light and the Red wire of the CHMSL light. Insert the Blue wire into the outer slot of the scotch lock and insert the Red wire into the blunt end of the Scotch lock. Then fold over the plastic cover and crimp the Scotch lock together.

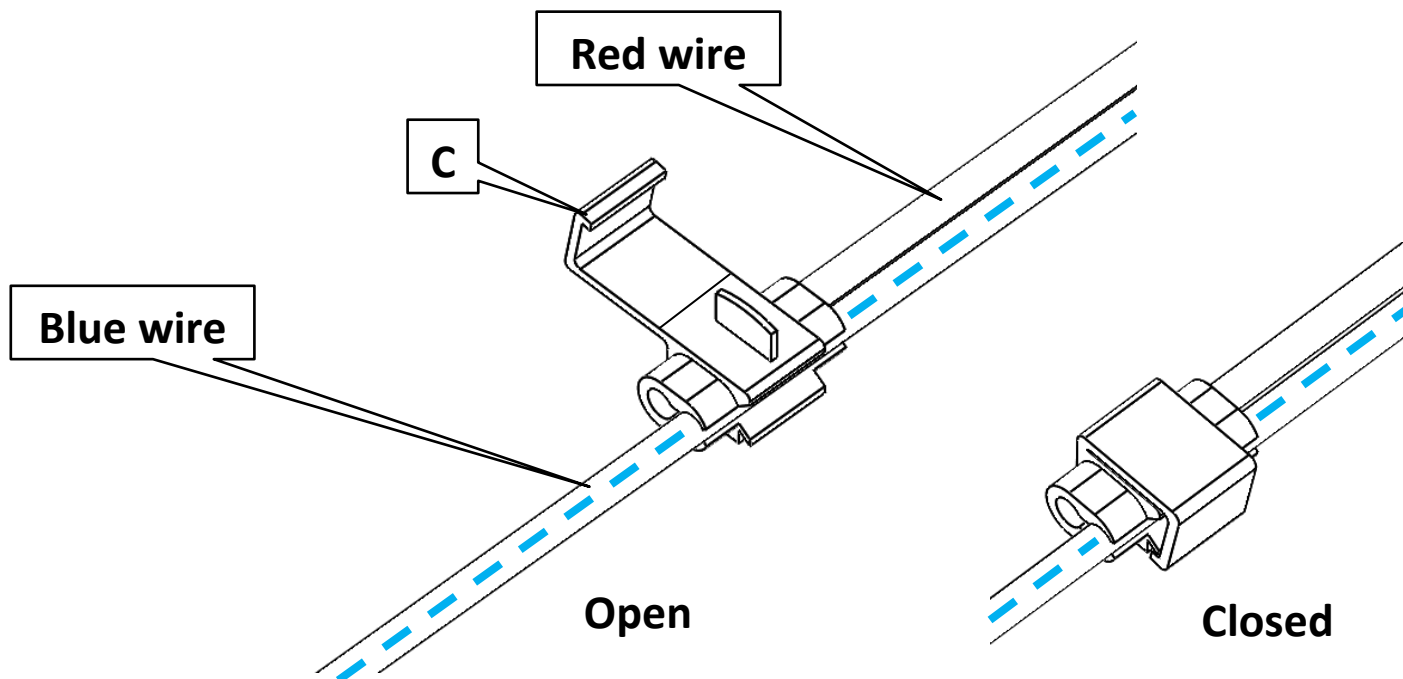

- 4** Strip the end of the Black wire of the CHMSL light and crimp the  $\frac{1}{4}$ " eyelet (A) onto the Black wire. Remove the ground bolt from step 2 and add the eyelet. Reinstall the bolt.

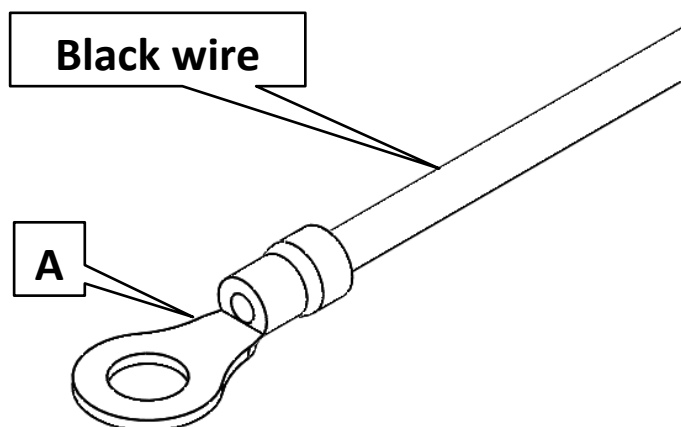

Use Wire Loom (G) and Zip-ties (G) to cover and hold up wires where preferred.

## Chevy/GMC 2007-2013 Wiring Instructions

- 1 Run the Red wire of the CHMSL light through the stake pocket towards the frame and run the wire up to the fuse box under the hood. Remove the fuse box cover and locate the CHMSL fuse.

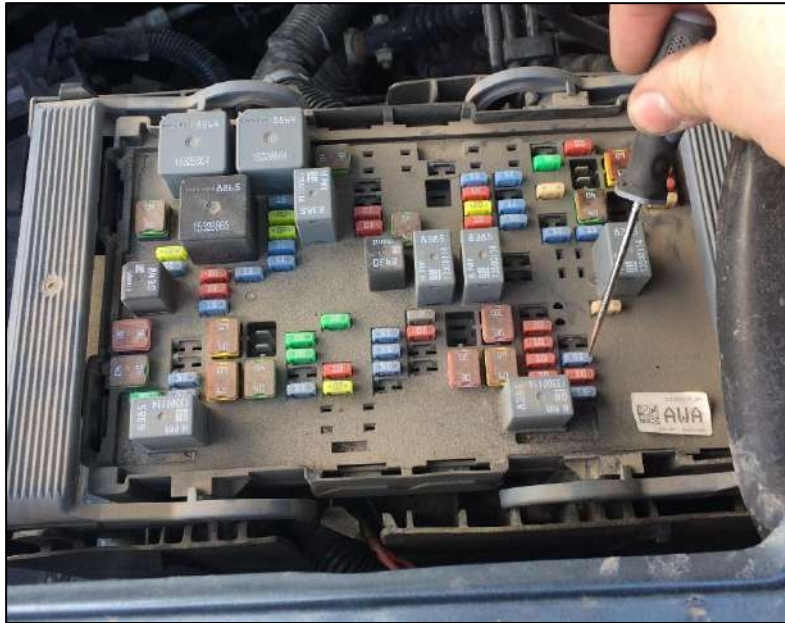

- 2 Run the Black wire of the CHMSL light through the stake pocket down towards the frame of the truck and locate the ground bolt as shown.

**Bolt**



- 3** Remove the CHSML fuse and install the Mini Add-A-Fuse (D) in its place reinstall the original fuse into the bottom slot of the Add-A-Fuse. Strip and crimp the Red wire into the wire coming out of the Add-A-Fuse and add a 10 amp Mini fuse (F) into the top slot of the Add-A-Fuse.

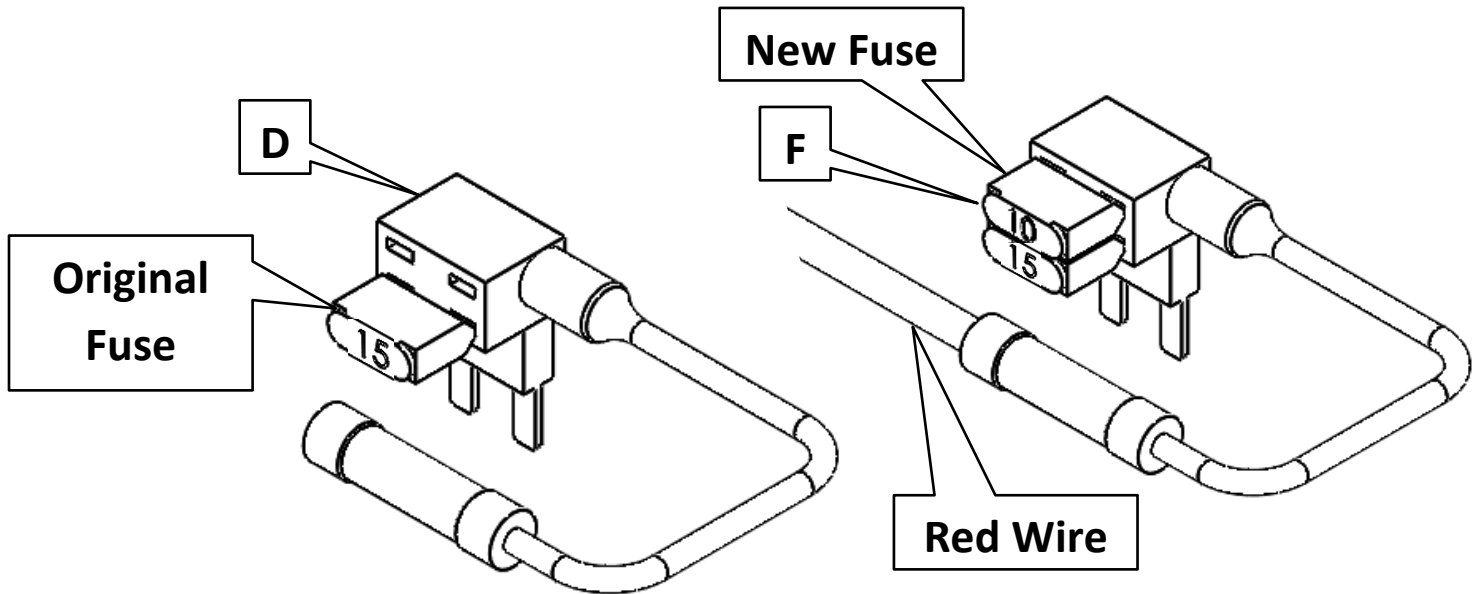

- 4** Strip the end of the Black wire of the CHMSL light and crimp the ¼" eyelet (A) onto the Black wire. Remove the ground bolt from step 2 and add the eyelet. Reinstall the bolt.

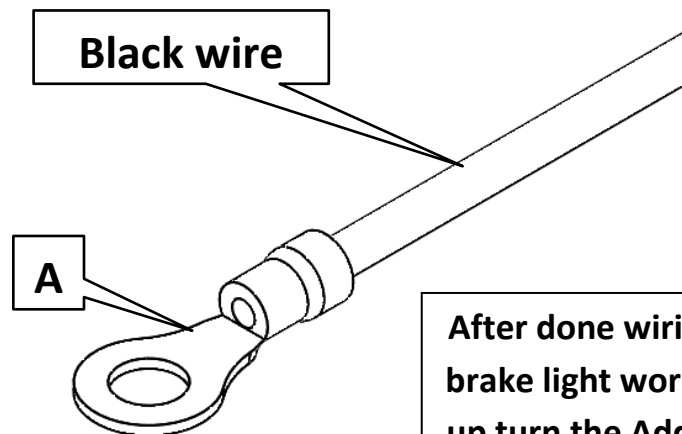

After done wiring, confirm the third brake light works. If it does not light up turn the Add-A-Fuse 180 degrees around in the Fuse box.

Use Wire Loom (G) and Zip-ties (G) to cover and hold up wires where preferred.

## Chevy/GMC 2014-Current Wiring Instructions

- 1 Run the Red wire of the CHMSL light through the stake pocket towards the frame and run the wire up to the fuse box under the hood. Remove the fuse box cover and locate the CHMSL fuse.



- 2 Run the Black wire of the CHMSL light through the stake pocket down towards the frame of the truck and locate the ground bolt as shown.

Bolt



- 3** Remove the CHMSL fuse and install the Micro Add-A-Fuse (E) in its place reinstall the original fuse into the bottom slot of the Add-A-Fuse. Strip and crimp the Red wire into the wire coming out of the Add-A-Fuse and add a 10 amp Micro fuse (F) into the top slot of the Add-A-Fuse.

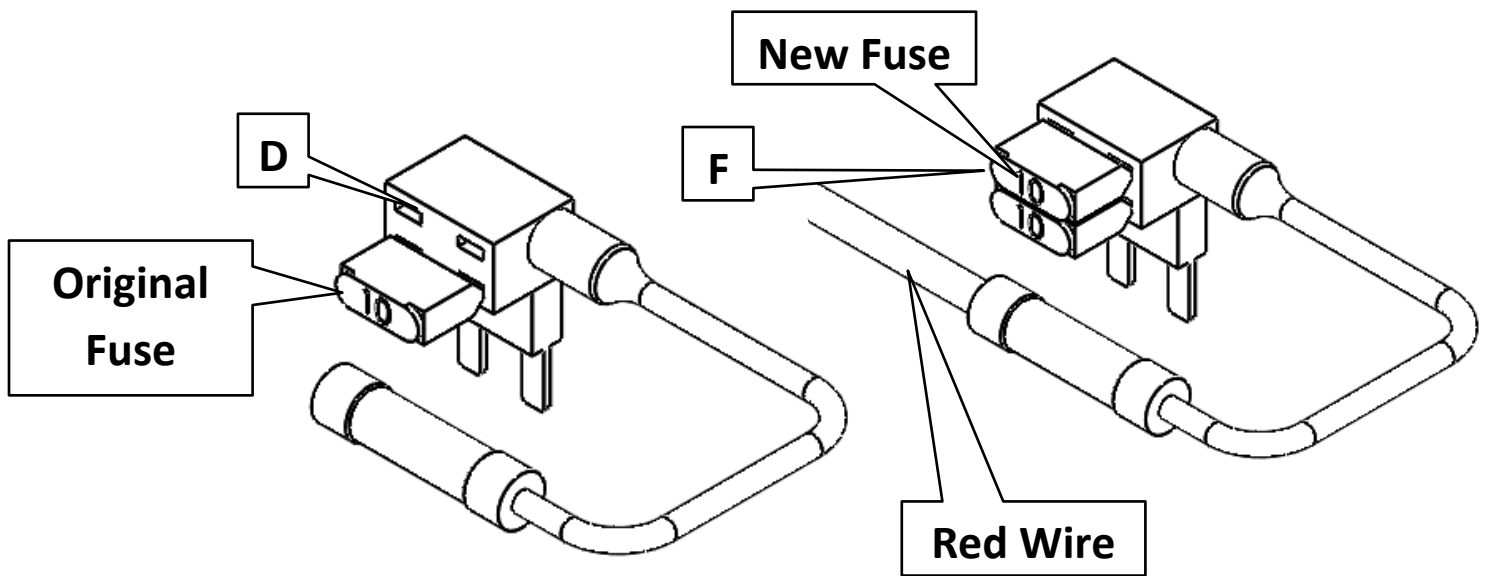

- 4** Strip the end of the Black wire of the CHMSL light and crimp the  $\frac{1}{4}$ " eyelet (A) onto the Black wire. Remove the ground bolt from step 2 and add the eyelet. Reinstall the bolt.

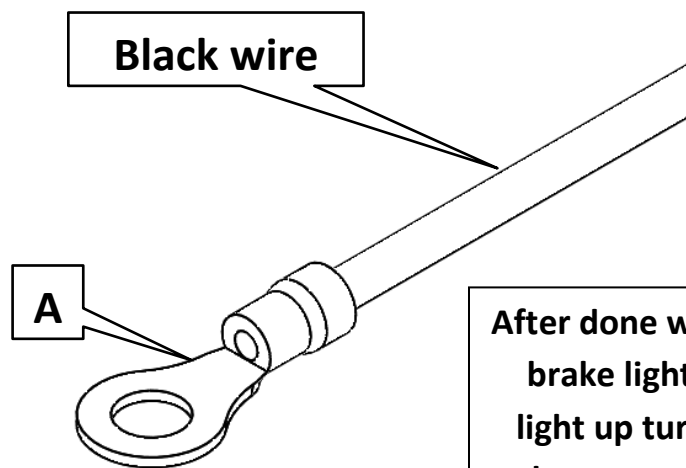

After done wiring, confirm the third brake light works. If it does not light up turn the Add-A-Fuse 180 degrees around in the Fuse box.

Use Wire Loom (G) and Zip-ties (G) to cover and hold up wires where preferred.

## Ford F-150 2009-2014 Wiring Instructions

- 1 Run the Red wire of the CHMSL light through the stake pocket towards the frame and run the wire up under the hood. Locate the Blue with Orange Stripe wire that is between the coolant tank and the firewall, it is taped to a main wire loom.

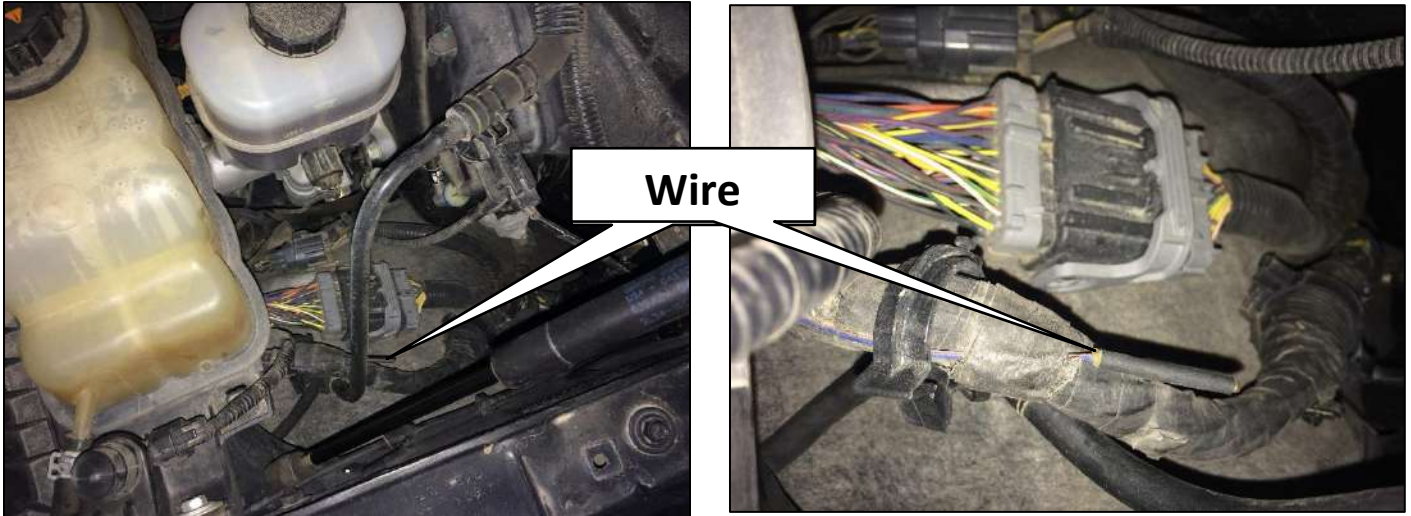

- 2 Run the Black wire of the CHMSL light through the stake pocket down towards the frame of the truck and locate the ground bolt as shown.

Bolt



- 3** Use the scotch lock (C) to connect the Blue with Orange Stripe wire and the Red wire of the CHMSL light. Insert the Blue with Orange Stripe wire into the outer slot of the scotch lock and insert the Red wire into the blunt end of the Scotch lock. Then fold over the plastic cover and crimp the Scotch lock together.

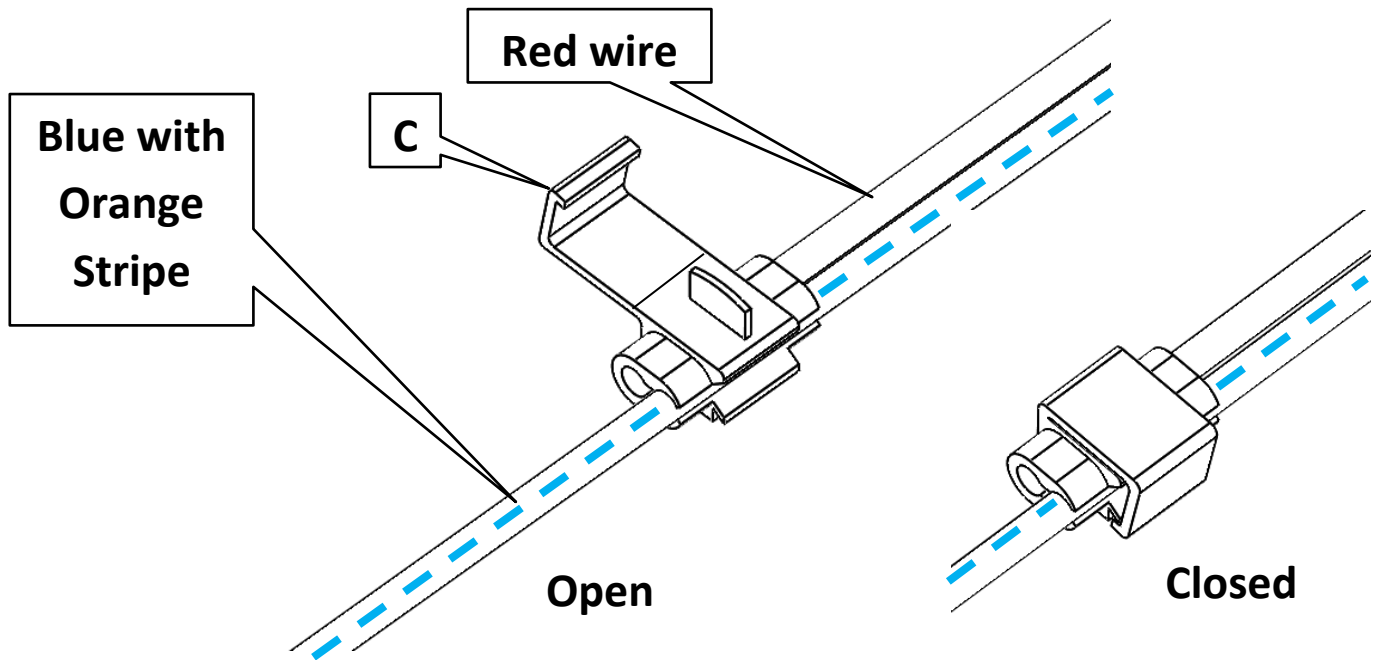

- 4** Strip the end of the Black wire and crimp the 3/8" eyelet (B) onto the Black wire. Remove the ground bolt from step 2 and add the eyelet. Reinstall the bolt.

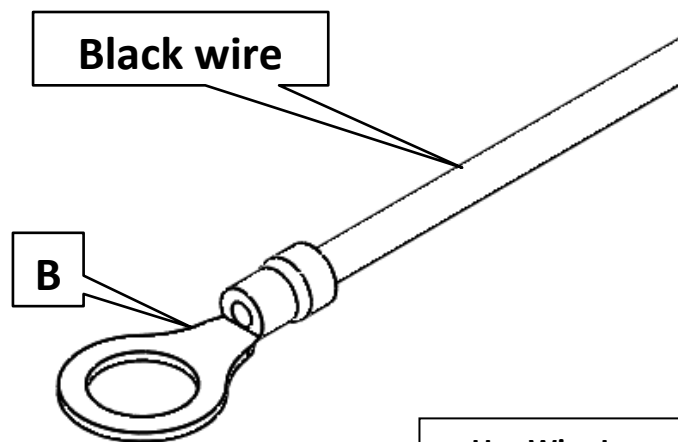

Use Wire Loom (G) and Zip-ties (G) to cover and hold up wires where preferred.



## Ford F-150 2015-Current Wiring Instructions

- 1 Run the Red wire of the CHMSL light through the stake pocket towards the frame and run the wire up under the hood. Run the wire through the firewall by cutting the zip tie on the rubber boot where the main wire loom goes through the firewall.



Cut zip tie

- 2 Remove the Driver side kick panel by first pulling straight up on the piece that is shown.



Pull up

- 3** Remove the Driver side kick panel by pulling up towards the bottom then pulling towards the rear of the vehicle.

Then Pull  
Rearward here



Pull up here first

- 4** Locate the Purple with a White Stripe wire in the Black Plug. Insert the Purple with White Stripe wire into the outer slot of the scotch lock (C) and insert the Red wire into the blunt end of the Scotch lock. Then fold over the plastic cover and crimp the Scotch lock together. Then reinstall the driver side kick panel and the top piece.

Purple with  
White Stripe

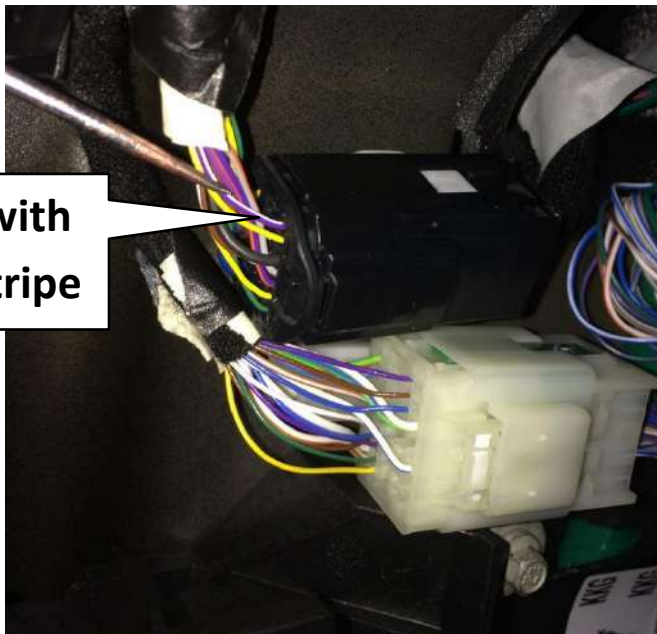

Purple  
with  
White  
Stripe

Red  
wire

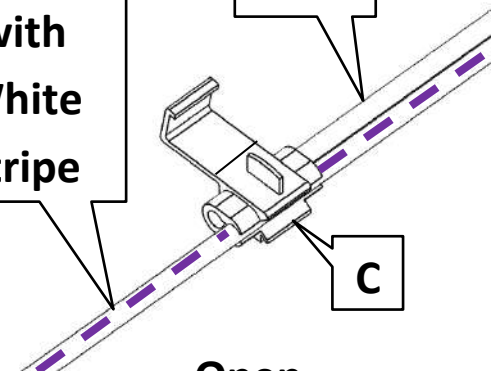

Open

Closed

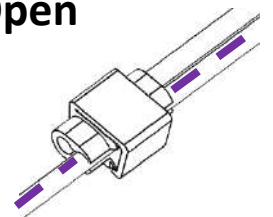

- 5** Run the Black wire of the CHMSL light through the stake pocket down towards the frame of the truck and locate the ground bolt as shown.

**Bolt**



- 6** Strip the end of the Black wire of the CHMSL light and crimp the 3/8" eyelet (B) onto the Black wire. Remove the ground bolt from step 5 and add the eyelet. Reinstall the bolt.

**Black wire**

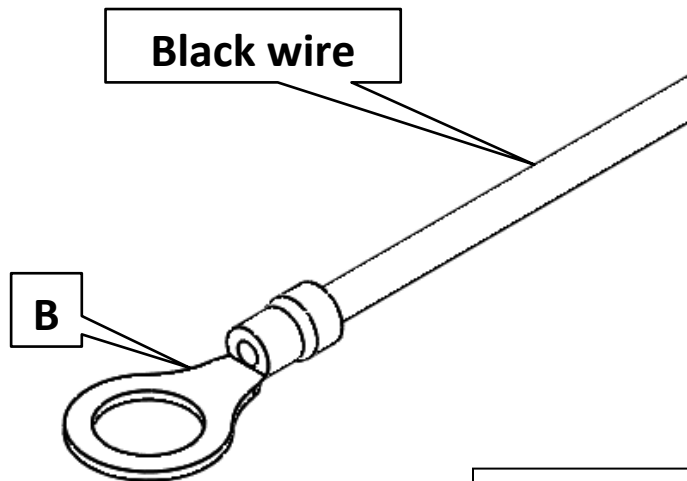

Use Wire Loom (G) and Zip-ties (G) to cover and hold up wires where preferred.

## Nissan Titan 2017-Current Wiring Instructions

1

Run the Red wire of the CHMSL light through the stake pocket and back to the driver side brake light. Remove the brake light and locate the Red wire in the top light socket.



Red wire

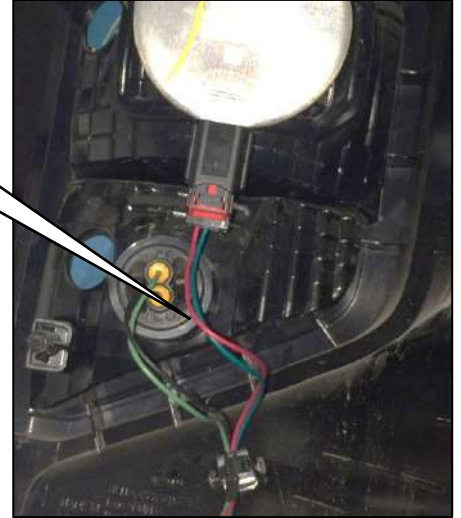

2

Run the Black wire of the CHMSL light through the stake pocket down towards the frame of the truck and locate the ground bolt as shown.

Bolt



- 3** Use the scotch lock (C) to connect the Red wire of the tail light and the Red wire of the CHMSL light. Insert the Red wire of the Tail light into the outer slot of the scotch lock (C) and insert the Red wire of the CHMSL light into the blunt end of the Scotch lock. Then fold over the plastic cover and crimp the Scotch lock together.

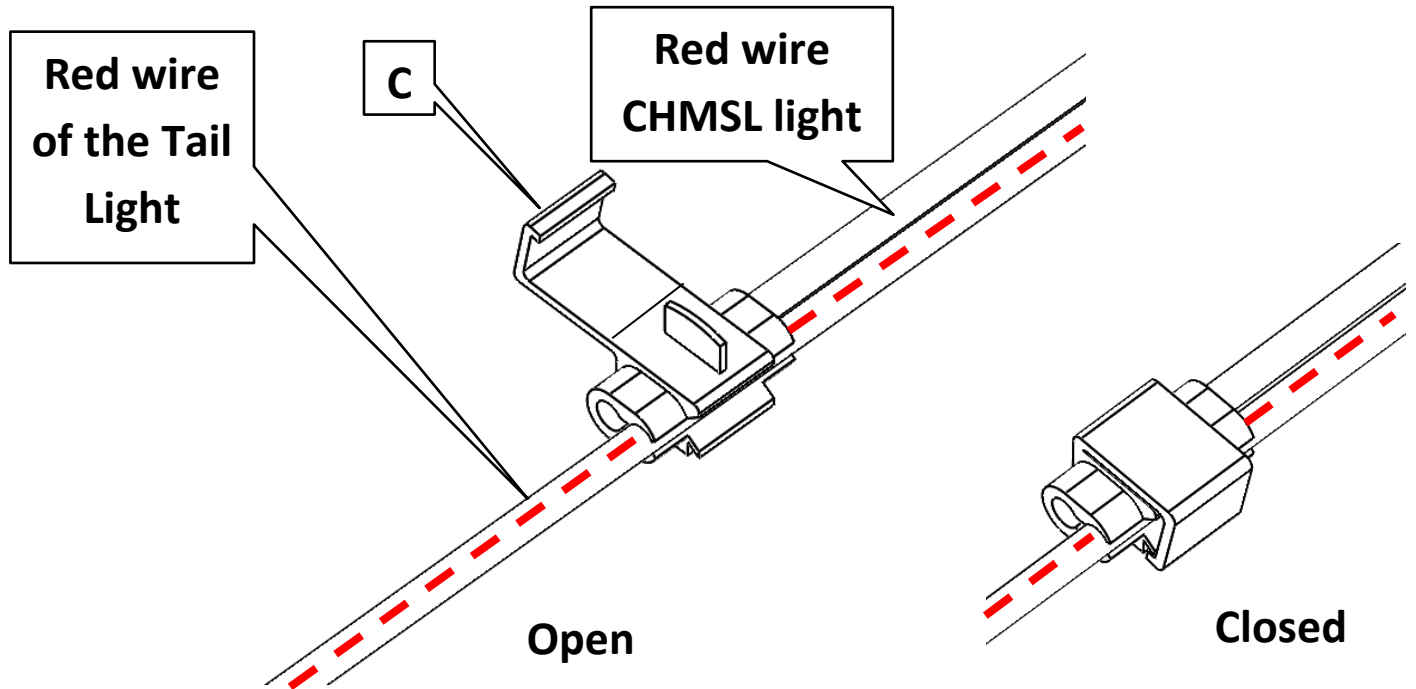

- 4** Strip the end of the Black wire of the CHMSL light and crimp the 3/8" eyelet (B) onto the Black wire. Remove the ground bolt from step 2 and add the eyelet. Reinstall the bolt.

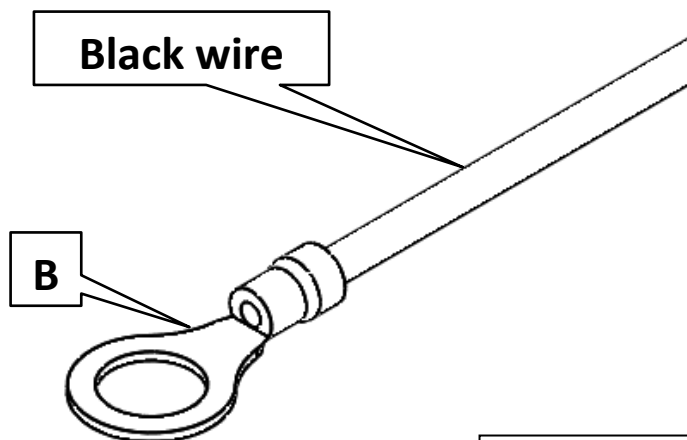

Use Wire Loom (G) and Zip-ties (G) to cover and hold up wires where preferred.

## Toyota Tundra 2007-2016 Wiring Instructions

- 1 Run the Red wire of the CHMSL light through the stake pocket and back to the driver side brake light. Remove the brake light and locate the Red wire in the bottom light socket.



- 2 Run the Black wire of the CHMSL light through the stake pocket down towards the frame of the truck and locate the ground bolt as shown.

Bolt



- 3** Use the scotch lock (C) to connect the Red wire of the tail light and the Red wire of the CHMSL light. Insert the Red wire of the Tail light into the outer slot of the scotch lock (C) and insert the Red wire of the CHMSL light into the blunt end of the Scotch lock. Then fold over the plastic cover and crimp the Scotch lock together.

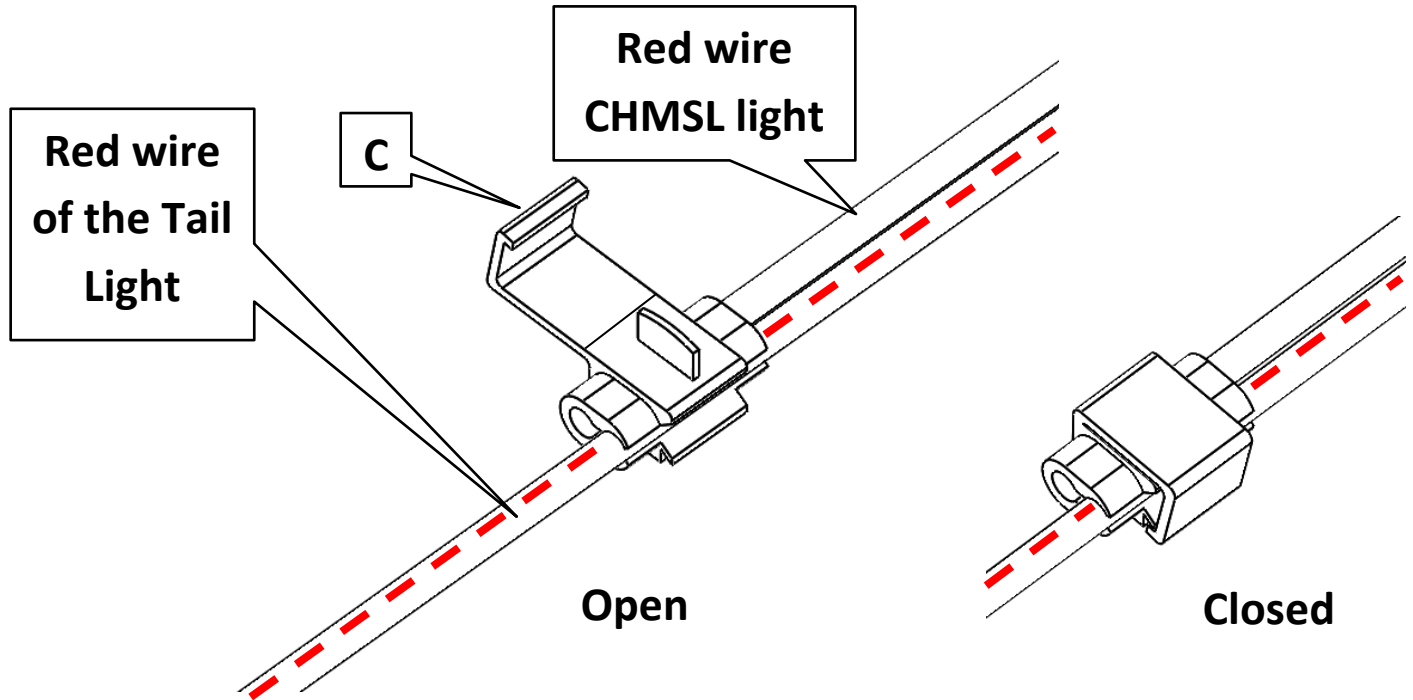

- 4** Strip the end of the Black wire of the CHMSL light and crimp the 3/8" eyelet (B) onto the Black wire. Remove the ground bolt from step 2 and add the eyelet. Reinstall the bolt.

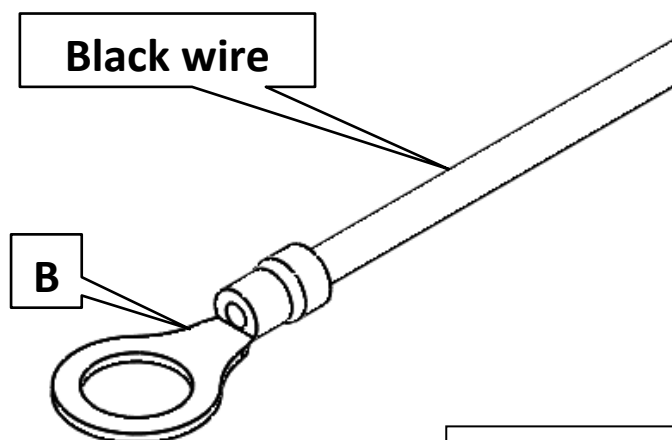

Use Wire Loom (G) and Zip-ties (G) to cover and hold up wires where preferred.

DZ 960050B